

B A S F 6 1 3 8

MINI DISK DRIVE

Specification

Mannheim, April 1983  
VID/WMS

Spec.Nr. 80307-058  
Rev. 01  
Pages: 20

## CONTENTS

1. Product Outline .....	1
1-1 Feature .....	1
1-2 Specifications .....	1
2. Interface .....	4
2-1 Signal Interface .....	4
2-2 Table of Connector Used .....	5
2-3 Input/Output Interface .....	6
2-4 Timing Chart .....	10
2-5 Multiple Drive Connection System .....	13
3. Description of Functions .....	14
3-1 Overall Block Diagram .....	14
3-2 Circuit Block Diagram .....	14
3-3 Jumper Functions .....	14
3-4 Arrangement of Jumper Pins .....	15
4. Dimension Specifications .....	16
4-1 Installation Method .....	16
4-2 Exterior of Unit .....	17
5. Handling Mini Floppy Disks .....	18
6. Format Example .....	19

# 1. Product Outline

## 1-1 Feature

This MDD employs a high performance direct-drive spindle motor, resulting in stability of media rotation and also freedom from maintenance due to the elimination of a driving belt. It also employs a high-speed stepping motor and steel belt drive system, permitting speedier seek-access by the head, and making for improved track positioning accuracy.

## 1-2 Specifications

### 1-2-1 Performance

		MDD221
Recording density	per diskette per track	1M byte 6.25K byte
Data transfer speed		250K bit/sec
Access time	Track-to-track shift time Seek settling time Average access time Head load waiting time Media rotating speed Average rotation waiting time Spindle motor starting time	3ms MAX 20ms MAX 95ms 25ms MAX 300 rpm 100ms 1S MAX
Recording density (inner periphery)		5922 BPI
Number of tracks		160
Modulation system		FM/MFM
Recommended media		BASF FlexyDisk 5.25"-2/96

Note 1: The waiting time during seek is the track-to-track shift time + seek settling time.

Note 2: The average access time is the average track-to-track shift time + seek settling time.

### 1-2-2 Boundary Conditions

Operating ambient temperature	5 - 45°C
Temperature during transport	-40 - 62°C
Storage temperature	-22 - 55°C
Relative humidity	20% to 80% (max, wet bulb temperature 29°C, free of dew formation)

### 1-2-3 Power Source

+5V • ±5% ripple 50 mVp-p and below	TYP 0.8A MAX 1.0A
+12V • ±5% ripple 100 mVp-p and below	TYP 0.8A MAX 1.7A

### 1-2-4 Machine Dimensions

Width	146 mm
Height	33.5 mm
Depth	221 mm
Weight	1.2 kg

\* For details, refer to dimension specifications.

### 1-2-5 Vibration and Shock

Vibration during operation	1G (5 - 100Hz) X, Y, and Z directions
Vibration during transportation	3G (5 - 100Hz) X, Y, and Z directions (in packed condition)
Shock during transportation	Shall satisfy all specifications when dropped from a height of 100cm in packed condition (in all directions, one corner, three ridgelines, and six planes)

### 1-2-6 Reliability

MTBF	10,000 POH
MTTR	30 minutes
Unit life	5 years
Soft read error	$10^{-9}$ bits
Hard read error	$10^{-12}$ bits
Seek error	$10^{-6}$ seek operations

2. Interface

2-1 Signal Interface

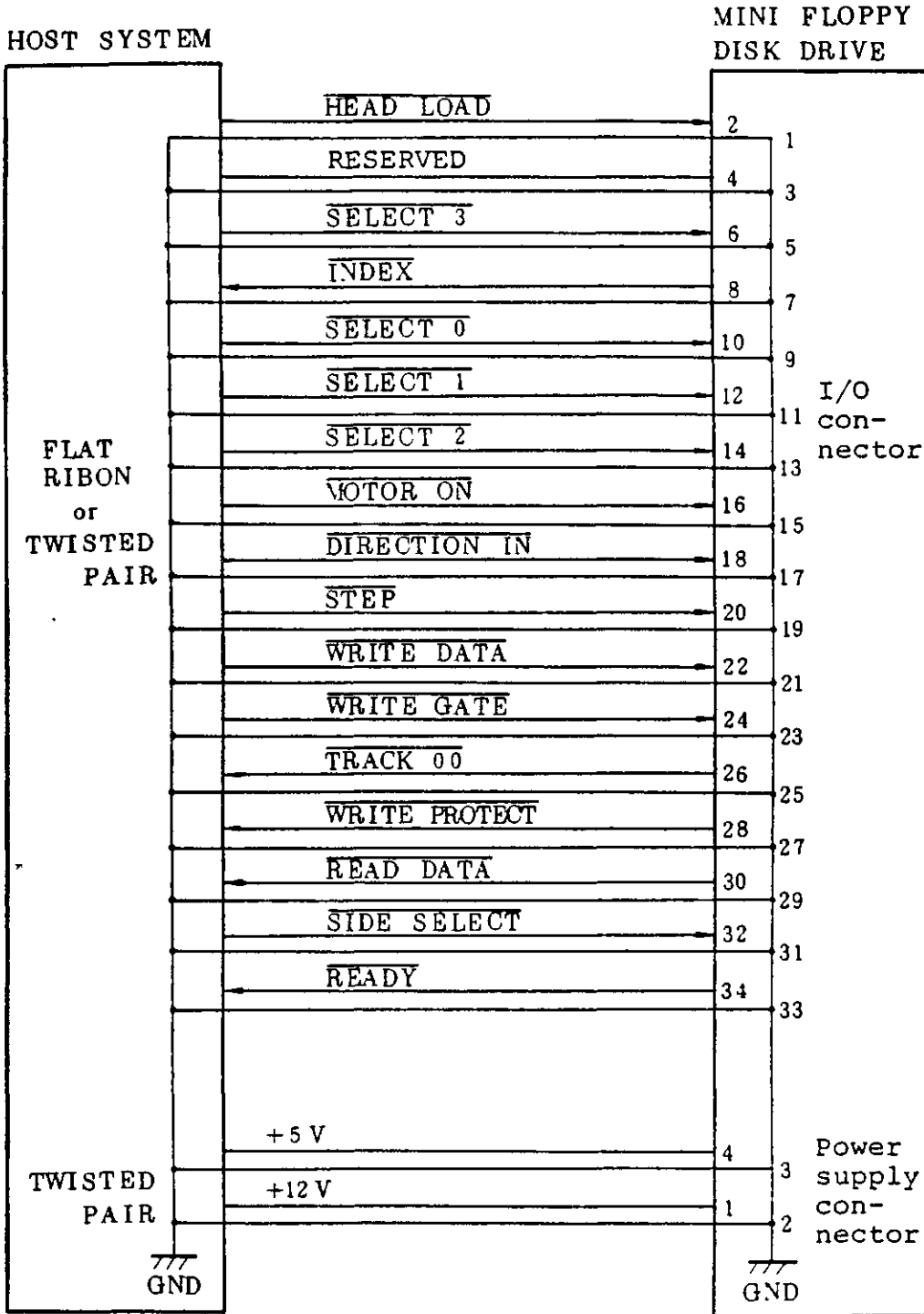

2-2 Table of Connector Used

Figs. 2-1 and 2-2 are simplified drawings of the connector used on the interface of the MDD. Suitable mating connectors are shown in the table below.

Signal connector	Scotchflex ribbon connector	3463-0000 3463-0001
	Yamaichi connector	FDS-34-12 #1 FDS-34-12 #2
Power supply connector	AMP (housing)	1-480424-0
	AMP (pin)	170148-2 (AWG18 - 24)
	AMP (pin)	170121-4 (AWG14 - 20)

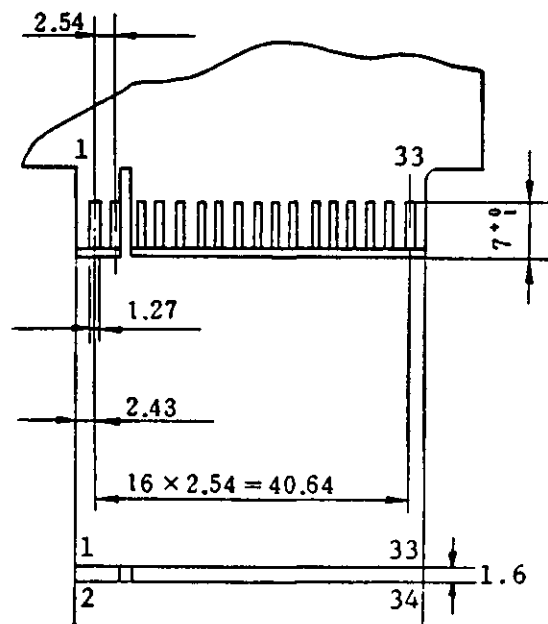
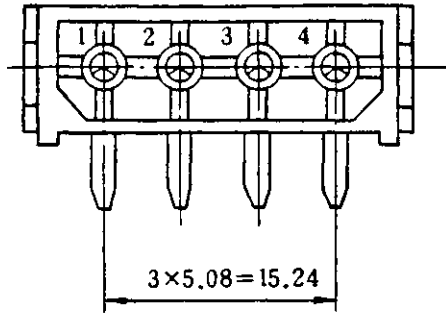

Fig. 2-1 Signal connector



Connector No.

- 1 ..... +12 V DC
- 2 ..... +12 V RETURN ( GROUND )
- 3 ..... + 5 V RETURN ( GROUND )
- 4 ..... + 5 V DC

Fig. 2-2 Power supply connector

2-3 Input/Output Interface

2-3-1 Recommended Input/Output Interface

Negative logic

Logic 0	0.0 - 0.4V (active)
Logic 1	2.5 - 5.25V (inactive)

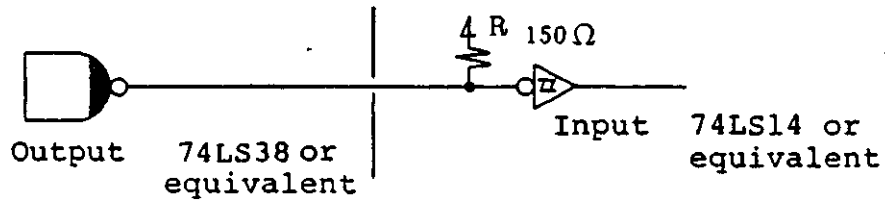



2-3-2 Input Signal Name

Signal name	Content
<p>Select 1 to 4</p>	<p>It is possible to connect up a maximum of four MDD units in a daisy chain.</p> <p>Set the drive select condition by means of the drive jumper pin. (All units are set to drive select 1 before they leave the factory.)</p> <p>When the select signal of the set drive becomes low level, the drive will go into an active condition.</p>
<p>Motor ON</p>	<p>When this signal becomes low level, the drive motor will rotate. The motor signal alone is not gated by the select signal.</p>
<p>Direction in</p>	<p>When this signal is high level, the head will shift to the outer periphery under the step signal. When it is low level, it will shift to the inner periphery.</p>
<p>Step</p>	<p>This signal is a pulse signal. The head will shift in the direction of the 'direction in' signal under the leading edge (fall) of this pulse.</p> <p>When the write gate is on, internally it goes into an inhibit condition.</p>
<p>Write gate</p>	<p>When this signal is low level, information is registered in the media in accordance with the signal of the write data. Also, the write gate signal functions to cause tunnel erase to take place inside the drive, hence neither side select nor step head unload will take place until 1.2 ms after the write gate has closed.</p>

Signal name	Content
Write data	<p>This signal is a pulse signal. Under the leading edge of the pulse (fall), the data will be inverted and information will be registered in the media.</p> <p>Transfer data only when the write gate is low level.</p>
Head load	<p>When this signal becomes low, the head will be loaded. It is also possible to perform head loading by means of the drive selector signal, irrespective of the head load signal. During head load, the indicator LED becomes red and the button is interlocked. For details, see the jumper specifications.</p>
Side selector	<p>This signal is used to select a particular head on a drive employing a double sided head. When it is high level, head 0 is selected, and when it is low level, head 1 is selected.</p>
Ready	<p>After the motor goes on and the media reaches a constant speed of rotation, this signal will go on (low level).</p> <p>After a lapse of 1 second from when the motor goes on, the ready signal is confirmed and R/W operation commences. Then, the indication LED becomes green.</p>
Track 00	<p>This signal is on (low level) when the head is at track 00.</p>

Signal name	Content
Index	<p>This signal goes on (low level) when the index hole of the media is detected.</p> <p>This signal is a 3 to 5 ms pulse signal.</p> <p>The leading edge (fall) of the pulse indicates the commencement of the track/sector.</p> <p>When the media is not inserted, this signal will remain low level.</p>
Read data	<p>This is a readout signal for magnetic inversion on the media. It is a pulse signal, the leading edge (fall) of which is effective.</p>
Write protect	<p>This signal becomes low level when a write-protected media is inserted. Simultaneously, write will be inhibited inside the drive.</p> <p>Write protect takes place by covering the notch in the disk jacket by an opaque label.</p>

\* All output signals are gated by the drive select signal.

## 2-4 Timing Chart

### 2-4-1 Ready Signal Timing

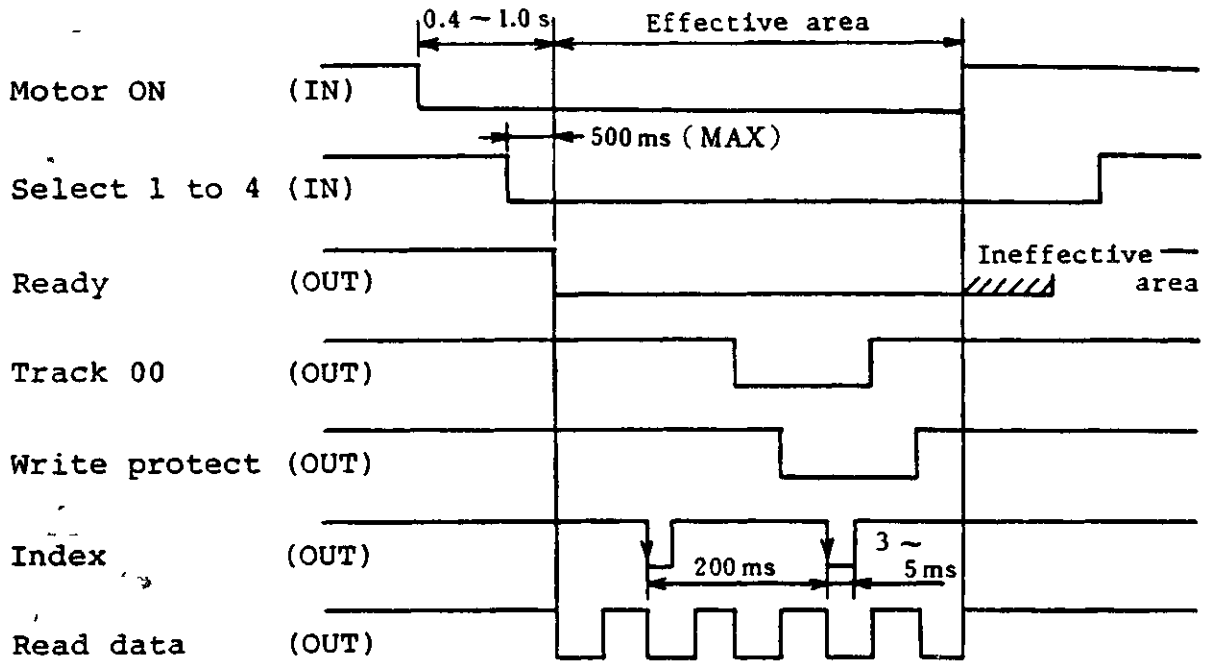

### 2-4-2 Step Signal Timing

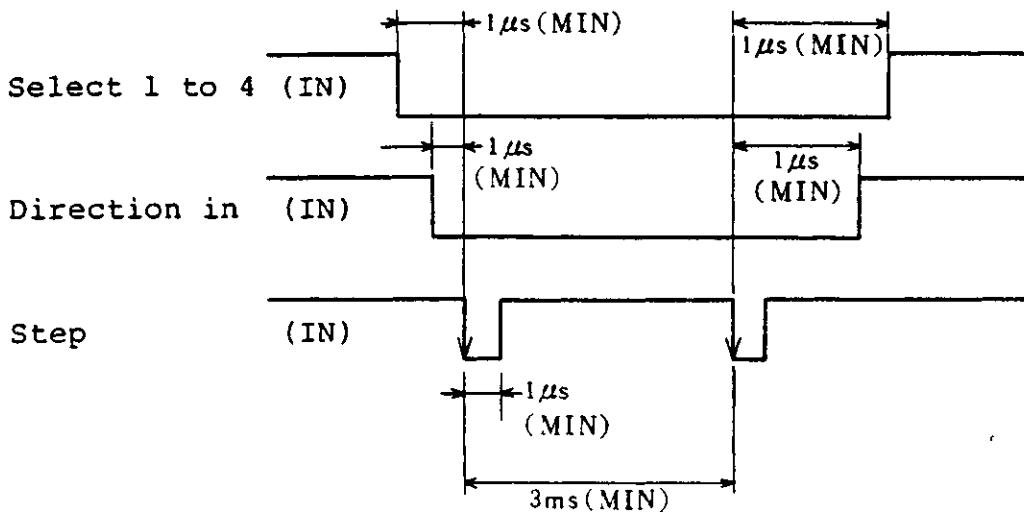

### 2-4-3 Readout Timing

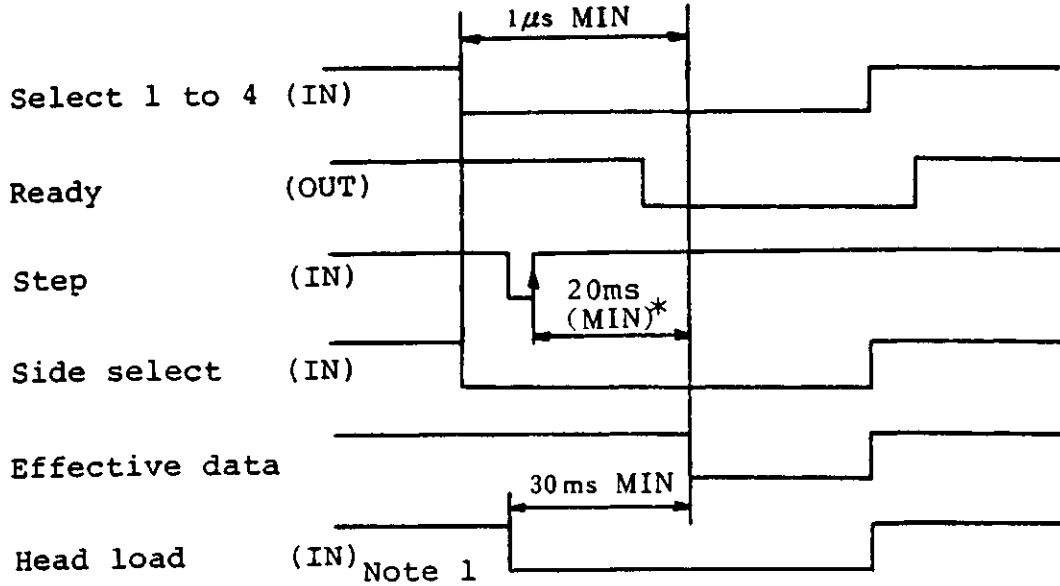

### 2-4-4 Write Timing

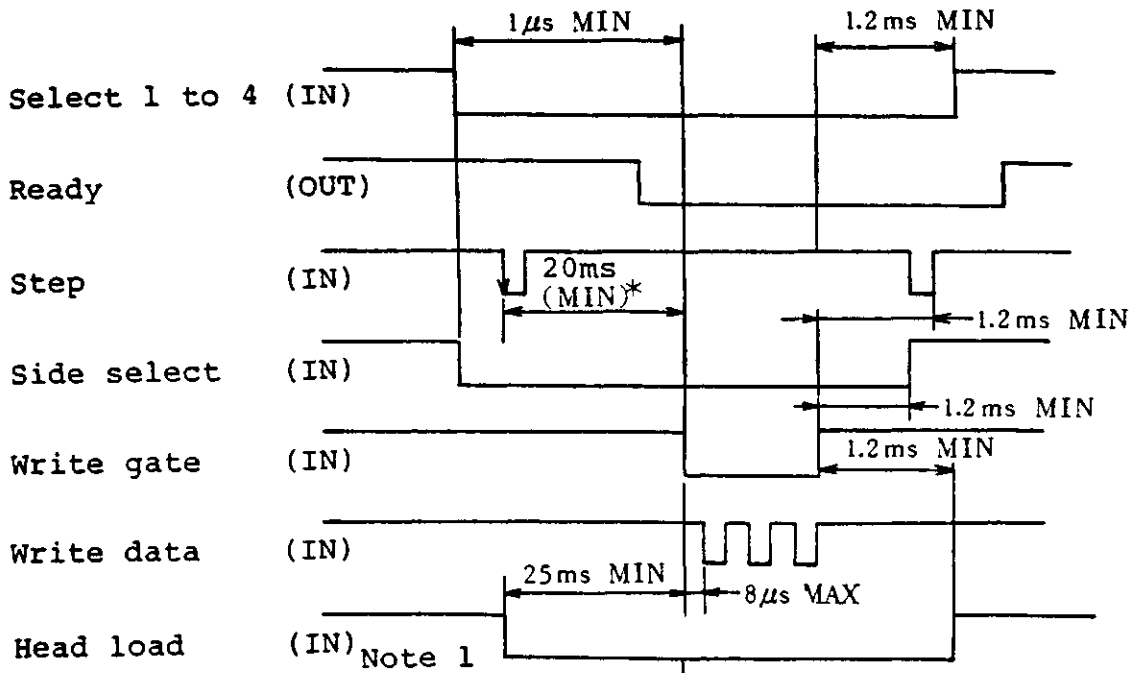

**Note 1:** The necessary head load waiting time is 25ms from the commencement of actual head loading. (For example, 25ms from 'select c-' when head loading by 'select' signal.)

### 2-4-5 Read Data (OUT)

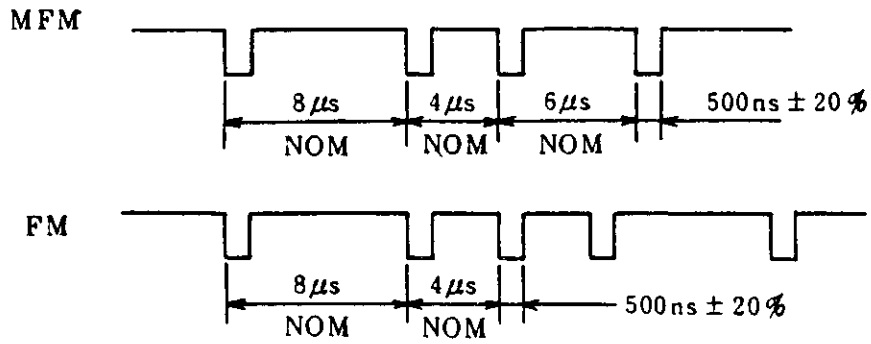

### 2-4-6 Write Data (IN)

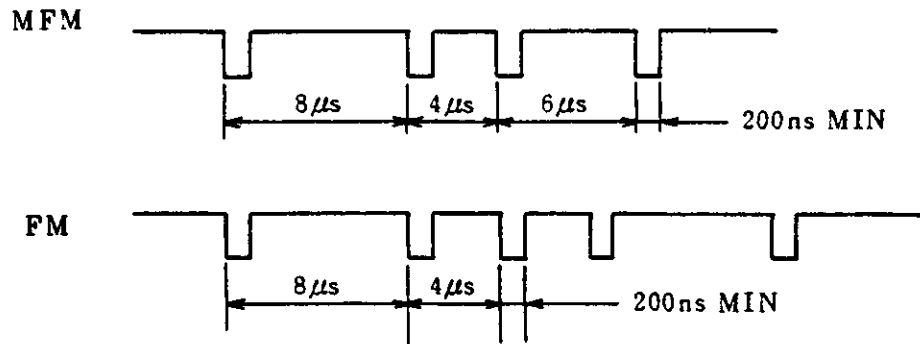

Use a write clock accuracy of  $\pm 0.5\%$  ( $4\mu\text{s} \pm 20\text{ns}$ ).

Normally, write pre-compensation is not necessary.

If it is necessary on account of the system, use it only from the center track in the peripheral direction.

## 2-5 Multiple Drive Connection System

When connecting several MDD units to a host system, either a radial connecting method or a daisy chain connecting method is used.

When using the daisy chain connecting method, it is necessary to remove all pull-up resistors (resistor arrays) except that on the last MDD unit.

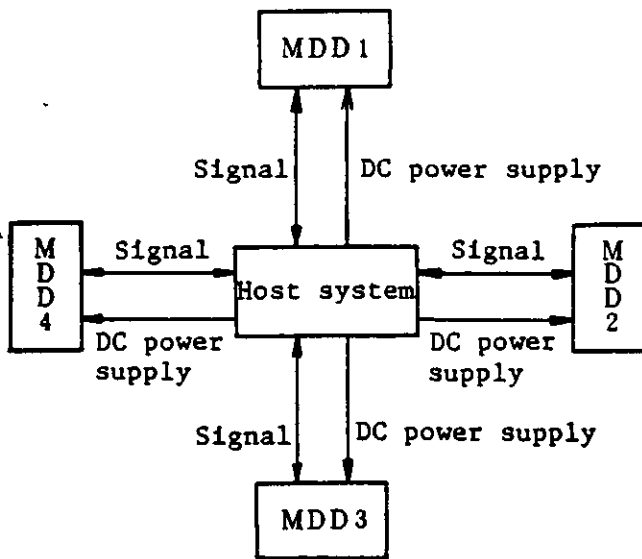

Radial connection

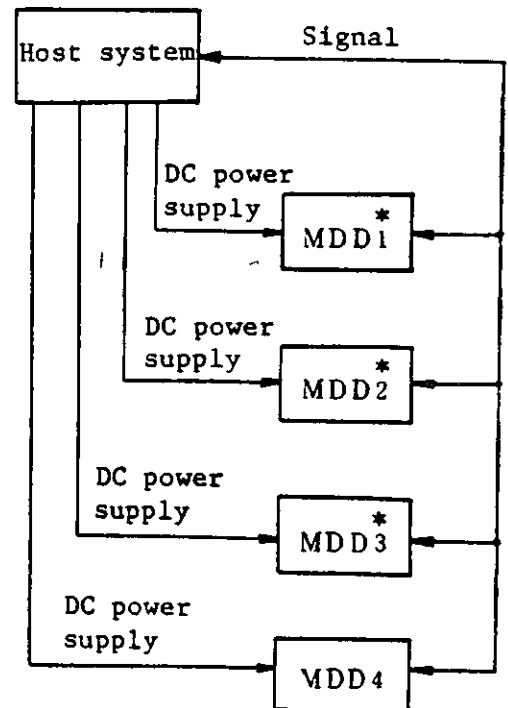

\* Remove resistor arrays.  
Daisy chain connection

### 3. Description of Functions

#### 3-1 Overall Block Diagram

The main components of the MDD are a spindle motor (DD motor), stepping motor, head assembly, main PCB, and other drive components.

#### 3-2 Circuit Block Diagram

Apart from the control circuit of the spindle motor, the entire MDD circuit is on the main PCB.

#### 3-3 Jumper Functions

Table 3-1 shows the jumper selection for the MDD.

The way in which the jumpers are set at the factory is indicated on the unit.

If the unit is returned for repair, etc., we will redeliver it with the jumpers set to the initial factory specifications.

Set the jumpers according to whether drive select is to be performed using select '1' or '2', and also whether head loading is to be performed by means of a head load signal or during ready.



Function	Content	JJ1				JJ2	
		S1	S2	S3	S4	SH	AH
	Jumper mode at factory before shipment	o	x	x	x	o	x
Drive select	Drive select 1	o	x	x	x		
	" 2	x	o	x	x		
	" 3	x	x	o	x		
	" 4	x	x	x	o		
Head load selection	Head loading takes place under head loading signal					o	x
	Head loading takes place during drive select					x	o

Table 3-1 Jumper selection table

3-4 Arrangement of Jumper Pins

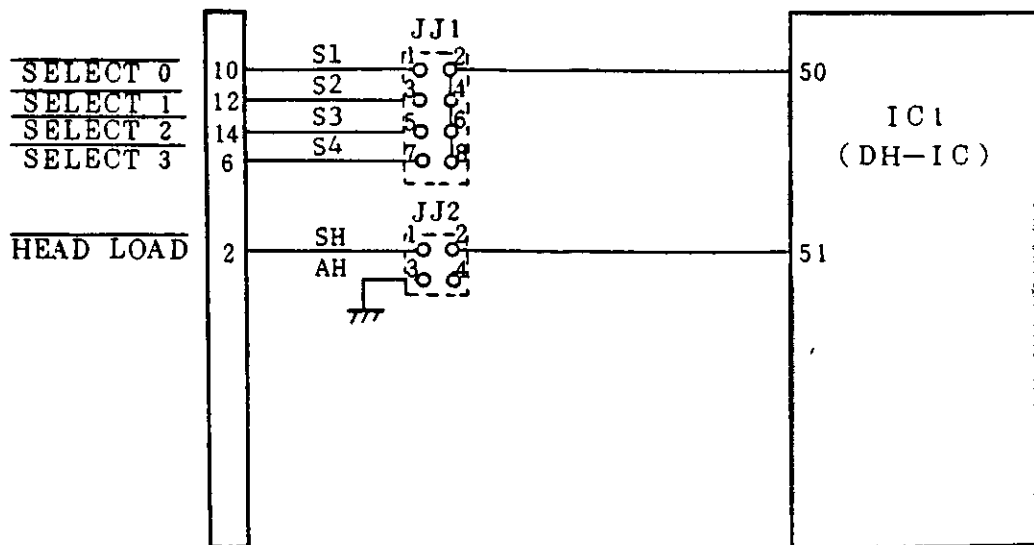

## C 4. Dimension Specifications

### 4-1 Installation Method

Install the MDD according to the method shown below.

- (1) Installation with PCB at top
- (2) Installation with PCB at right
- (3) Installation with PCB at left

1

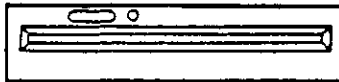

2



3



\* When using the unit near a CRT, printer, or other source of noise, it is recommended that a shield be used.

4-2 Exterior of Unit

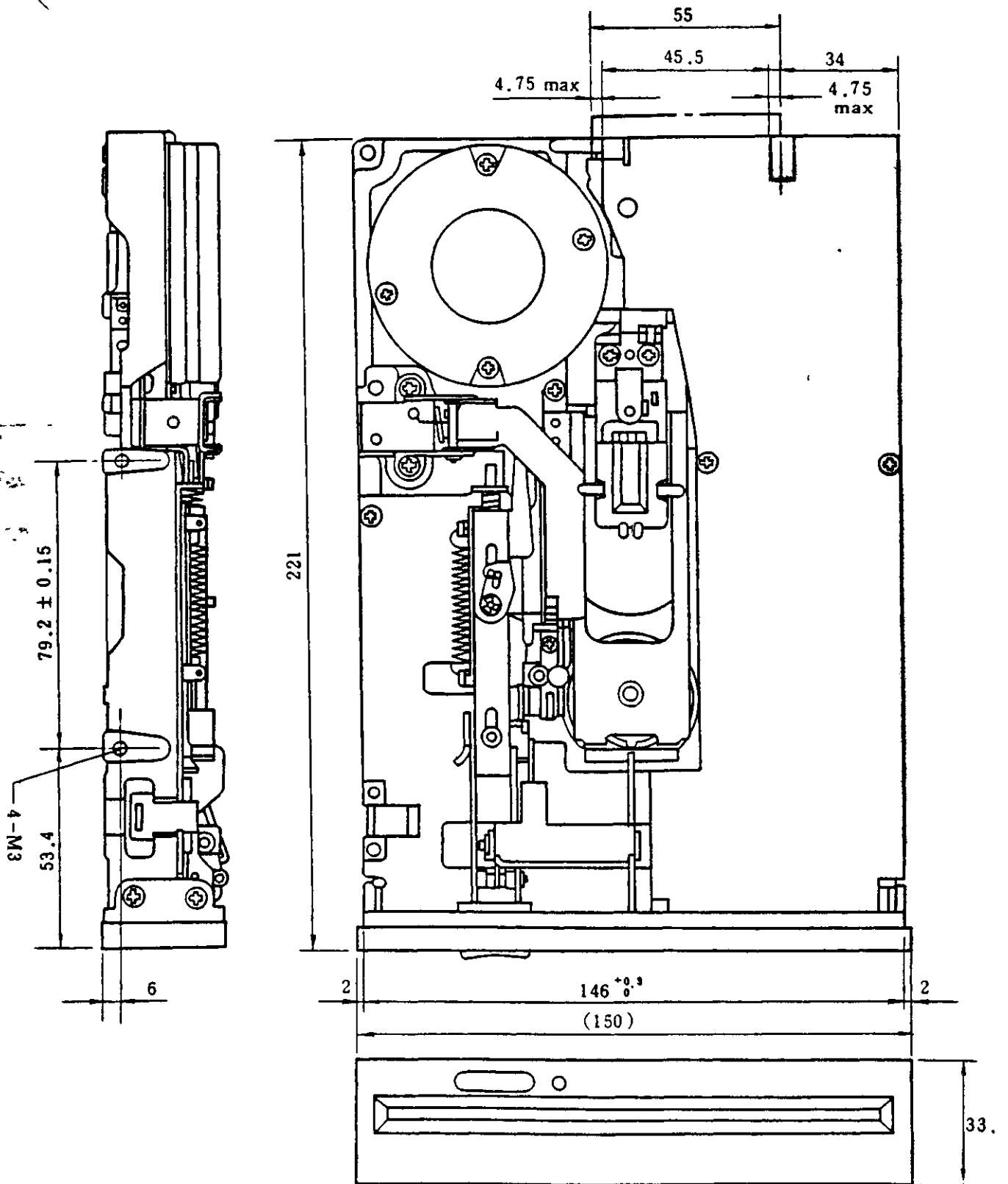

## 5. Handling Mini Floppy Disks

The following are the precautions to be observed when handling mini floppy disks.

### [Unsatisfactory]

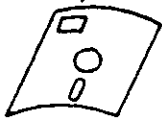
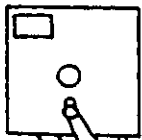
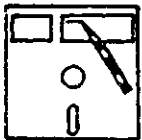
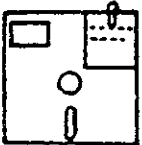
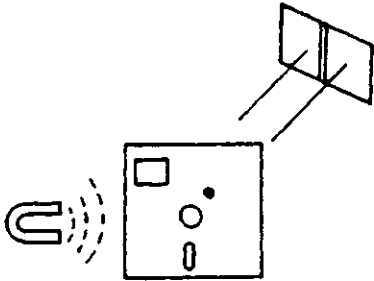

- o Do not expose disks to direct sunlight or place them near a source of heat.
- o Do not place disks in a place which is subject to the influence of a magnetic field.
- o Do not expose disks to cigarette smoke.
- o Do not put clips or rubber bands on disks.
- o Do not write directly on disks using a pen or pencil.
- o Do not touch the recording face of disks (oblong hole portion).
- o Do not bend or fold disks.

### [Satisfactory]

4 ~ 53°C  
8 ~ 80%RH

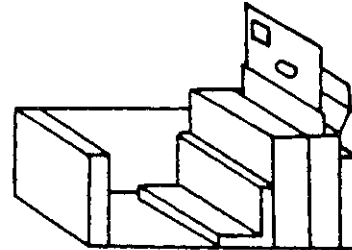

- o Store disks in a clean environment at suitable temperature and humidity.
- o When not using a disk, insert it in an envelope, then insert the envelope in a special-purpose case, and store it vertically.

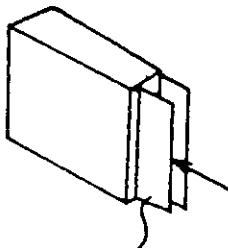
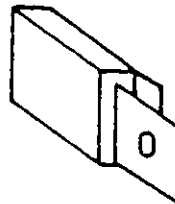
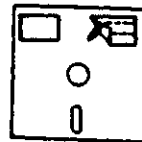

- o Paste labels on disks after writing on them first.
- o Before using a disk, it is recommended that it be left for a suitable time in the same environment as the drive in order to acclimatize it.
- o Completely insert the media to the back of the drive before closing the door.

## 6. Format Example

The format of the soft selector used with the MDD is shown in the table below.

Format examples for F.M. 16-sector format and M.F.M. 16-sector format are shown in Fig. 6-1.

	FM/MFM	Sector format	Data amount/sector	Data amount/track
Conformance to ISO	FM	16 sectors	128 bytes	2048 bytes
		9 "	256 "	2304 "
		5 "	512 "	2560 "
	MFM	16 "	256 "	4096 "
		9 "	512 "	4608 "
		5 "	1024 "	5120 "
Conformance to IBM	FM	15 "	128 "	1920 "
		8 "	256 "	2048 "
		4 "	512 "	2048 "
	MFM	16 "	256 "	4096 "
		8 "	512 "	4096 "
		4 "	1024 "	4096 "