

**VAXstation 3100 Upgrade
Installation Guide
Models 30 to 38
Models 40 to 48**

Order Number EK-345AA-IN-002

**digital equipment corporation
maynard, massachusetts**

Second Edition, January 1990

The information in this document is subject to change without notice and should not be construed as a commitment by Digital Equipment Corporation. Digital Equipment Corporation assumes no responsibility for any errors that may appear in this document.

The software described in this document is furnished under a license and may be used or copied only in accordance with the terms of such license.

No responsibility is assumed for the use or reliability of software on equipment that is not supplied by Digital Equipment Corporation or its affiliated companies.

Restricted Rights: Use, duplication, or disclosure by the U. S. Government is subject to restrictions as set forth in subparagraph (c) (1) (ii) of the Rights in Technical Data and Computer Software clause at DFARS 252.227-7013.

Copyright © Digital Equipment Corporation 1990

All Rights Reserved.
Printed in U.S.A.

FCC NOTICE: The equipment described in this manual generates, uses, and may emit radio frequency energy. The equipment has been type tested and found to comply with the limits for a Class A computing device pursuant to Subpart J of Part 15 of FCC Rules, which are designed to provide reasonable protection against such radio frequency interference when operated in a commercial environment. Operation of this equipment in a residential area may cause interference, in which case the user at his own expense may be required to take measures to correct the interference.

The following are trademarks of Digital Equipment Corporation:

DEC	DIBOL	UNIBUS
DEC/CMS	EduSystem	VAX
DEC/MMS	IAS	VAXcluster
DECnet	MASSEBUS	VMS
DECsystem-10	PDP	VT
DECSYSTEM-20	PDT	
DECUS	RSTS	
DECwriter	RSX	digital ™

This document was prepared and published by Educational Services Development and Publishing, Digital Equipment Corporation.

Contents

About This Guide

vii

1 Upgrading a Diskless Model 30

1.1	PV11U-AA Kit Contents	1
1.2	Preparing the System for Installation	2
1.3	Installing the Modules	7
1.4	Replacing the Power Supply Screws	12
1.5	Installing the New Bezel Insert	13
1.6	Installing the Upgrade Label	15
1.7	Reinstalling the System Box Cover	15
1.8	Completing the Installation	15

2 Upgrading a Model 30 (No Diskette)

2.1	PV11U-CA Kit Contents	16
2.2	Preparing the System for Installation	17
2.3	Installing the Modules	26
2.4	Installing the New Drive Plate	31
2.5	Configuring the Drives on the New Drive Plate	33
2.6	Installing the RZ22/RZ23 Disk Drive(s)	34
2.7	Installing the TZ30 Tape Drive	38
2.8	Replacing the Power Supply Screws	43
2.9	Changing the Medallion	44
2.10	Installing the Upgrade Label	44
2.11	Reinstalling the System Box Cover	44
2.12	Completing the Installation	44

3	Upgrading a Model 30 (With Diskette)	
3.1	PV11U-BA Kit Contents	45
3.2	Preparing the System for Installation	46
3.3	Installing the Modules	54
3.4	Installing the New Drive Plate	59
3.5	Configuring the Drives on the New Drive Plate	61
3.6	Installing the RZ22/RZ23 Disk Drive(s)	62
3.7	Installing the RX23 Diskette Drive	65
3.8	Replacing the Power Supply Screws	70
3.9	Installing the New Bezel Window	71
3.10	Installing the Upgrade Label	73
3.11	Reinstalling the System Box Cover	73
3.12	Completing the Installation	73

4	Upgrading the Model 40	
4.1	PV15U-AA Kit Contents	74
4.2	Preparing the System for Installation	75
4.3	Installing the Modules	84
4.4	Replacing the MSC Module	93
4.5	Changing the Medallion	93
4.6	Installing the Upgrade Label	94
4.7	Reinstalling the System Box Cover	94
4.8	Completing the Installation	94

A Upgrade and Return Forms

Index

Tables

1	Related Documents	viii
3-1	RX23 SCSI ID Switch Settings	66



About This Guide

This installation guide describes how to install the upgrade options that are available for the VAXstation 3100 systems. The upgrade is available on both the model 30 and model 40 VAXstation 3100 systems. The VAXstation system becomes a VAXstation 3100 system models 38 and 48 once the upgrade is complete.

Organization

There are four upgrade kits available. Each chapter describes how to install one of the four kits.

Chapter	Upgrade From	To
1	A diskless VAXstation 3100 model 30 system	A diskless VAXstation 3100 model 38 system
2	A VAXstation 3100 model 30 system without a diskette drive	A VAXstation 3100 model 38 system without a diskette drive. This system may or may not contain a TZ30 tape drive.
3	A VAXstation 3100 model 30 system with a diskette drive	A VAXstation 3100 model 38 system with a diskette drive
4	A VAXstation 3100 model 40 system	A VAXstation 3100 model 48 system

Intended Audience

This document is only for Digital Customer Services personnel.

Tools and Equipment

You need the following tools to service the VAXstation 3100 systems:

Tools and Equipment	Part Number
Wrist strap and antistatic mat (included in Field Service antistatic kit)	29-26246-00

Related Documents

You can order the following documents from Digital:

Table 1 Related Documents

Documents	Order Number
VAXstation 3100 Maintenance Guide	EK-285AA-MG
VAXstation 3100 Maintenance Guide Addendum Models 38 & 48	EK-344AA-AD
VAXstation 3100 Model 40 Customer Information Kit	EK-VS310-IL
Managing your VAXstation 3100 Model 30 Standalone	EK-260AA-OM
VAXstation 3100 Hardware Information Model 30	EK-265AA-OM
VAXstation 3100 Hardware Information Model 40	EK-266AA-OM
Using your VAXstation 3100 Model 30 Satellite	EK-259AA-UG
VAXstation 2000, MicroVAX 2000, VAXmate Network Guide	EK-NETAB-UG

Digital personnel may order the documents shown in Table 1 from:

Digital Equipment Corporation
444 Whitney Street
Northboro, MA 01532

Attn: Publishing and Circulation Services (NRO3/W3)
Order Processing Section

Conventions

This document uses the following conventions:

Convention	Meaning
Note	Provides general information
Caution	Provides information to prevent damage to the equipment
PN	Part number



Upgrading a Diskless Model 30

This chapter contains installation procedures for upgrading a diskless VAXstation 3100 model 30 system to a diskless VAXstation 3100 model 38 system.

1.1 PV11U-AA Kit Contents

The following table lists the contents and part numbers of the PV11U-AA kit:

Kit Item	Part Number
Bezel insert for FCC shielding	74-37499-02
KA42-BA system module	54-19356-01
Owners manual, network guide, site planning guide	EK-VSM30-DK
VAXstation 3100 Upgrade Installation Guide	EK-345AA-IN
Upgrade label	36-15946-01
Power supply caution label	36-20124-01
Medallion, VAXstation 3100 M 38	
Three power supply safety screws*	12-30934-01

*One screw is extra.

1.2 Preparing the System for Installation

To prepare the system for installation:

Shut Down the System

1. Shut down the system software.
2. Run a self-test to verify the operation of the present configuration.
 >>> TEST F 1
3. Turn the system power switch off.

Open the System Box

CAUTION

Wear a static wrist strap and use a static mat (PN 29-26242-00) when replacing FRUs.

1. Unscrew the two cover screws.

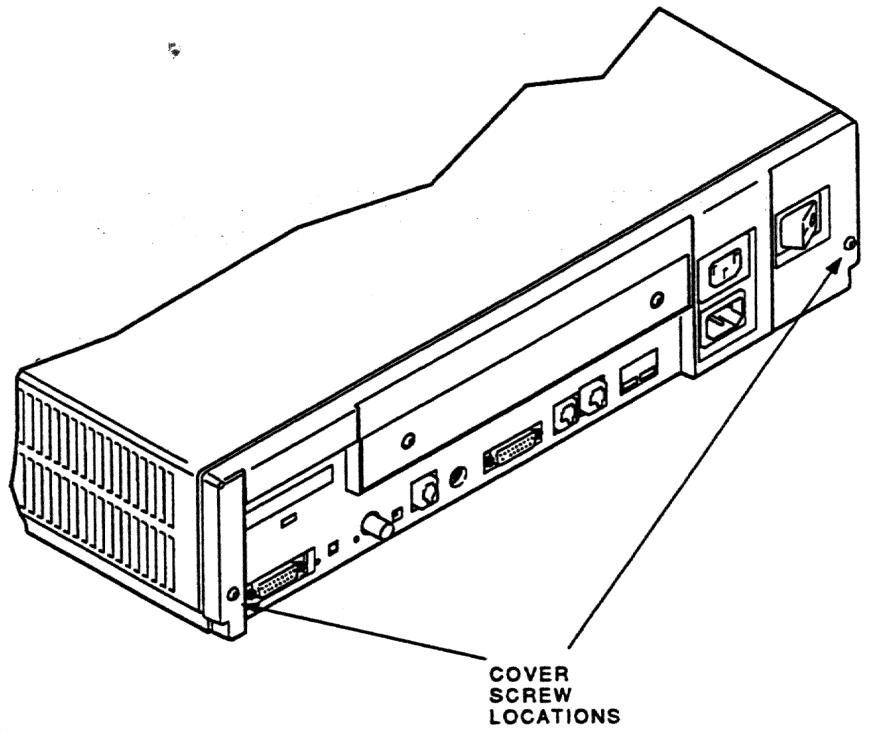

MA-X0796-88

2. Slide the cover forward and up off the system box.

4 Upgrading a Diskless Model 30

Remove the Memory Module

Remove the memory module from the four standoffs, then lift the memory module off the system module. Two connectors will disconnect as you lift the module.

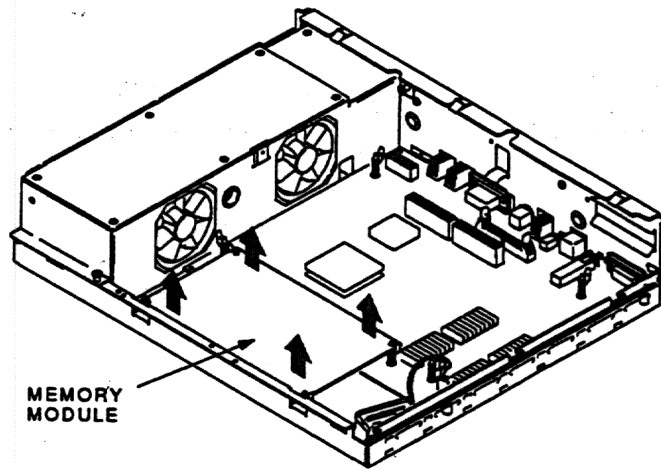

MA-X0804-88

Remove the Graphic Module (if present)

Remove the graphic module from the four standoffs, then lift the graphic module off the system module. Two connectors will disconnect as you lift the module.

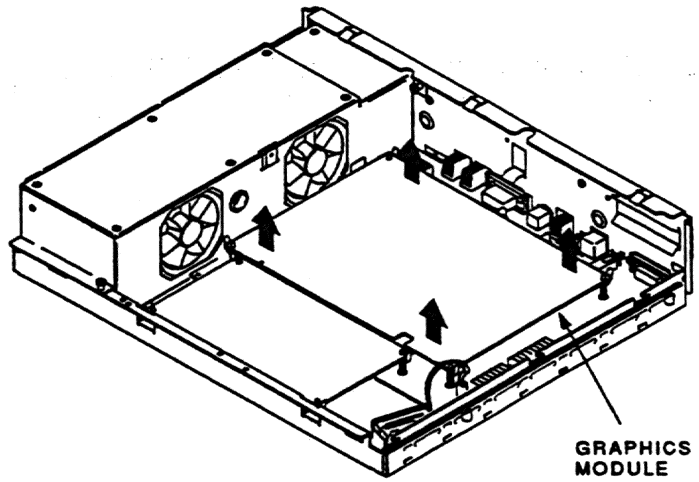

MA-X0803-88

Remove the System Module

1. Disconnect all cables from the back of the system box.

6 Upgrading a Diskless Model 30

NOTE

Before disconnecting the power cable in the next step, be sure to release the connector latch on the back side of the power connector.

2. Disconnect the power cable and the battery cable from the system module.

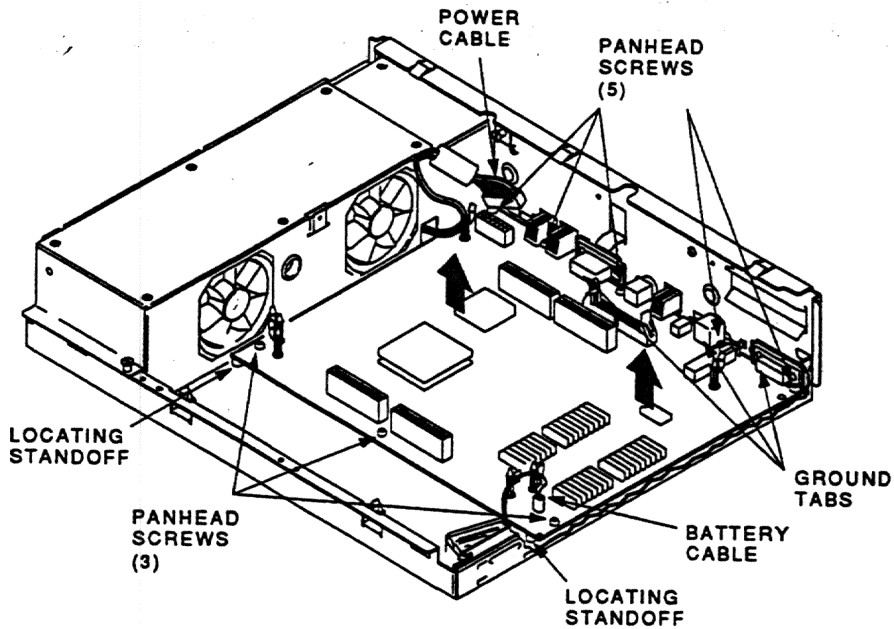

MA-X0805-88

3. Remove the eight screws from the system module.
4. Remove the system module by carefully popping off the two front corners of the two locating standoffs.

CAUTION

In the next step, you will swap the Ethernet ID ROMs on both the new system module and the old system module that you just removed. Be careful not to bend the pins on the ROM or not to mix up the ROM that goes on each system module.

5. Remove the Ethernet ID ROM from the system module you just removed. Set the ROM aside.

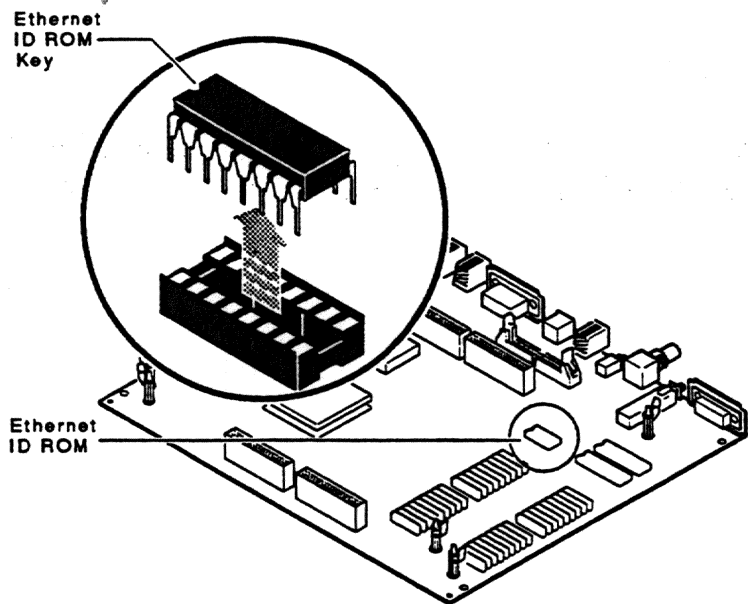

MLO-002918
MA-X0872-89

6. Remove the Ethernet ID ROM from the new system module in the kit and reinstall it on the old system module.
7. Take the ID ROM that you just removed from the old system module and install it on the new system module.

1.3 Installing the Modules

To install the modules:

Install the New System Module

NOTE

When installing the new system module, install the connector end first through the openings in the rear of the box. Push the module back to load the connector ground tabs. Snap the module on both locating standoffs. All screw holes will then be aligned.

8 Upgrading a Diskless Model 30

1. Check the position of the S3 switch next to the LEDs on the back of the system module. Be sure S3 is in the down position. The down position enables the monitor to be the console, and the up position enables a terminal connected to the printer port to be the console.
2. Install the connector end of the system module through the openings in the rear of the box. Push the module back to load the connector ground tabs, then snap the module on both locating standoffs. All screw holes will then be aligned.
3. Install the eight screws on the system module.

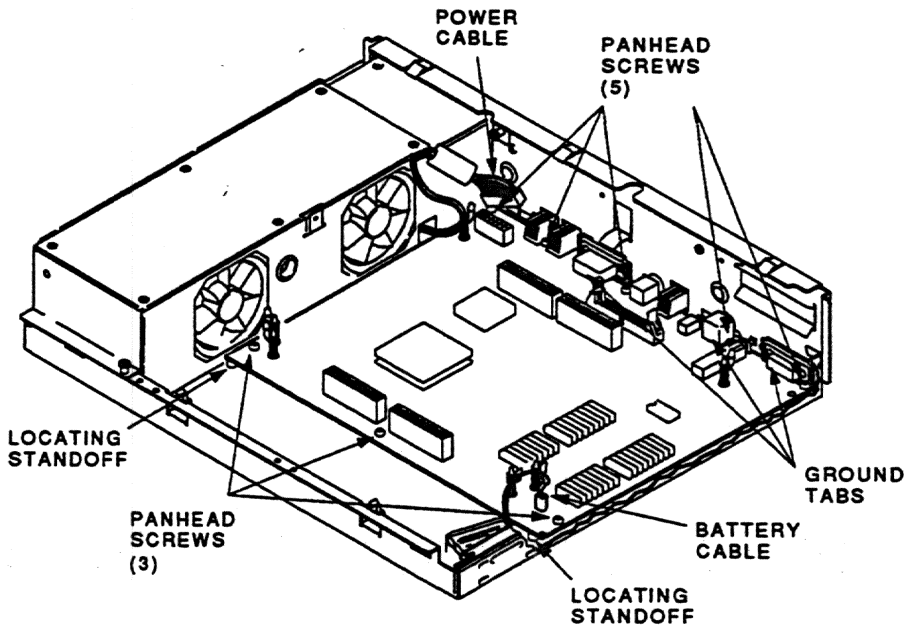

MA-X0805-88A

4. Connect the power cable and the battery cable to the system module.
5. Reconnect all cables to the back of the system box.

Reinstall the Memory Module

Install the memory module(s) on the new system module as shown in the following two figures. The first figure is for 4 or 12 Mbyte (single) memory module; the second figure is for 8 or 16 Mbyte (dual) memory module. After the module(s) are installed, press down on top of the module's connectors to firmly seat the connectors.

4 or 12 Mbyte (single) Memory Module Installation

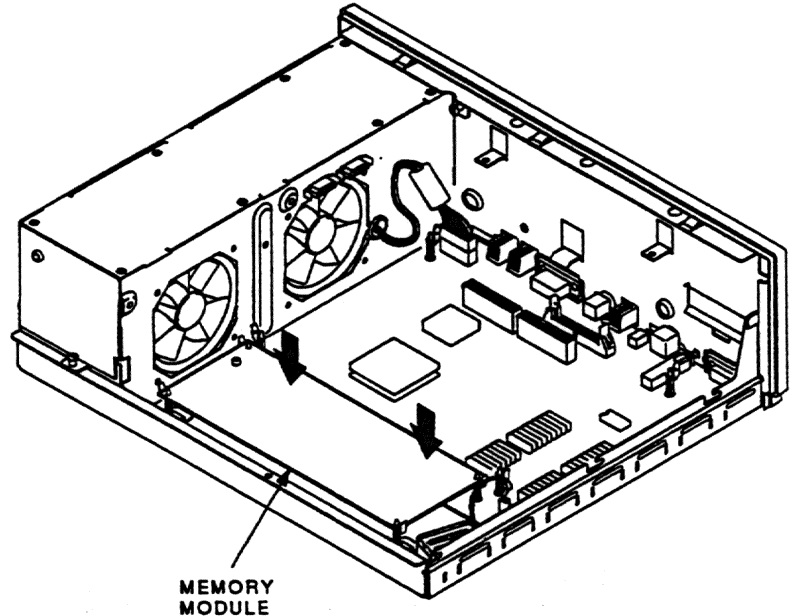

MA-X0848-88A

8 or 16 Mbyte (dual) Memory Module Installation

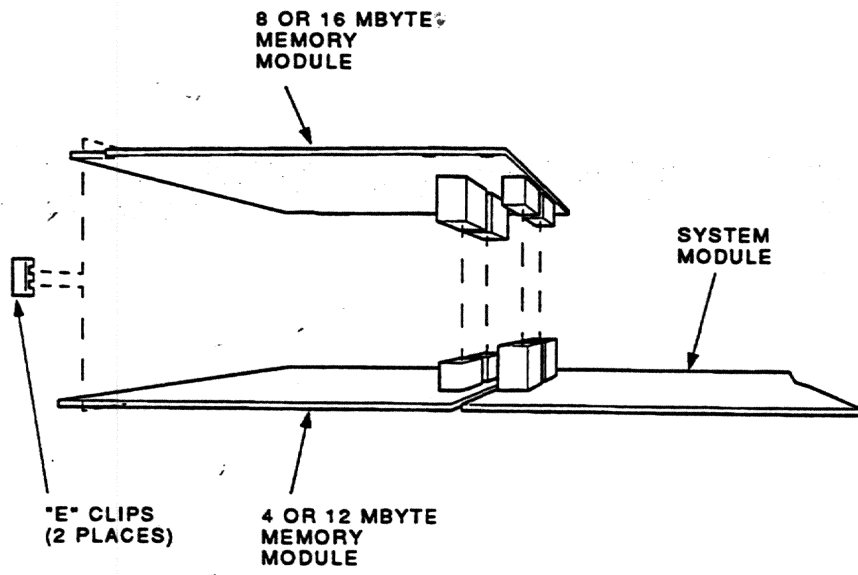

MA-X1174-88A

Reinstall the Graphic Module (If present)

Reinstall the graphics module on the new system module. After the module is installed, press down on top of the module's connectors to firmly seat the connectors.

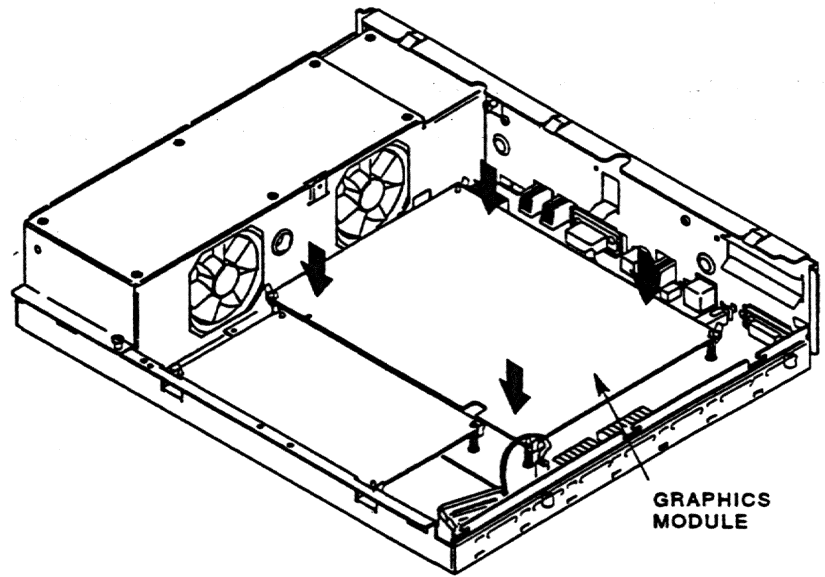

MA-X0803-88A

1.4 Replacing the Power Supply Screws

To replace the power supply screws:

1. Remove the two phillips-head screws from the side of the power supply.
2. Install two of the three torx-head power supply safety screws (PN 12-30934-01) from the kit into the side of the power supply using the torx-head screwdriver.

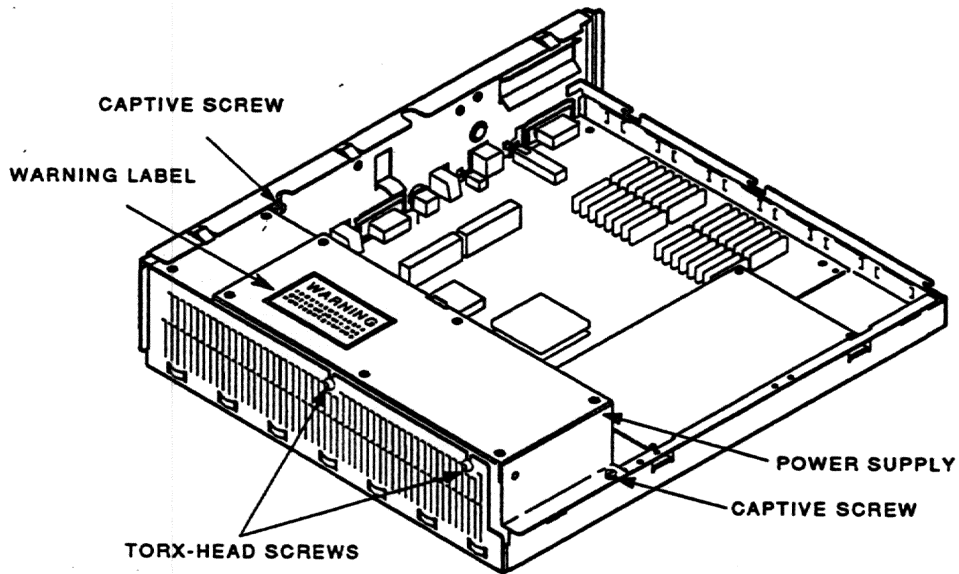

MA-X0808-88A

3. Install the power supply warning label on the power supply.

1.5 Installing the New Bezel Insert

To install the new bezel insert:

1. Remove the six screws on the cover of the system box, and remove the front bezel from the cover.

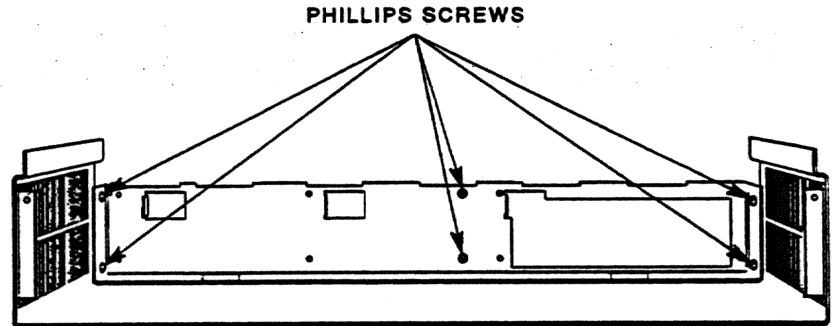

MA-X0517-89

14 Upgrading a Diskless Model 30

2. Separate the bezel insert from the front bezel.

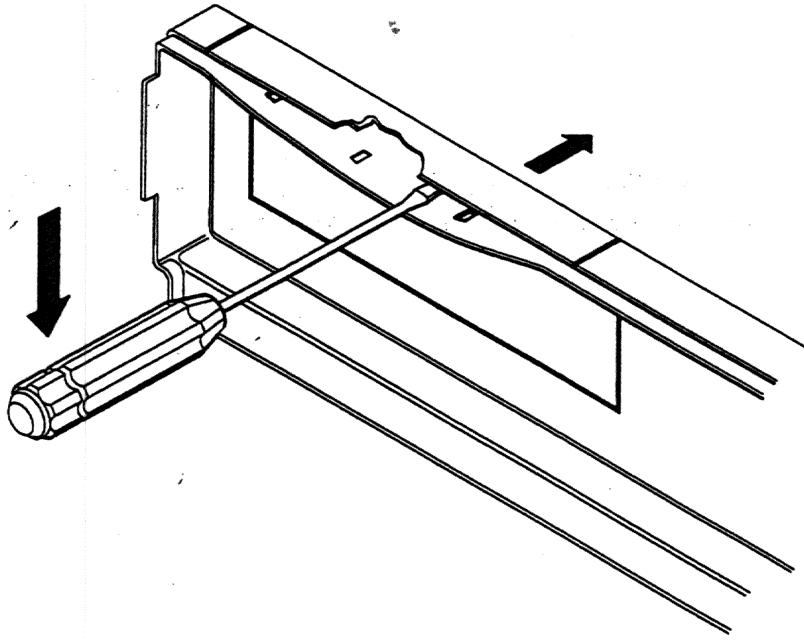

MA-X0518-89

3. Install the new bezel insert from the kit on the front bezel by reversing steps 1 and 2.
4. Remove the VAXstation 3100 medallion from the system box cover.
5. Install the new VAXstation 3100 M 38 medallion from the kit in the cover.

6. Reinstall the front bezel on the cover, then reinstall the six screws.

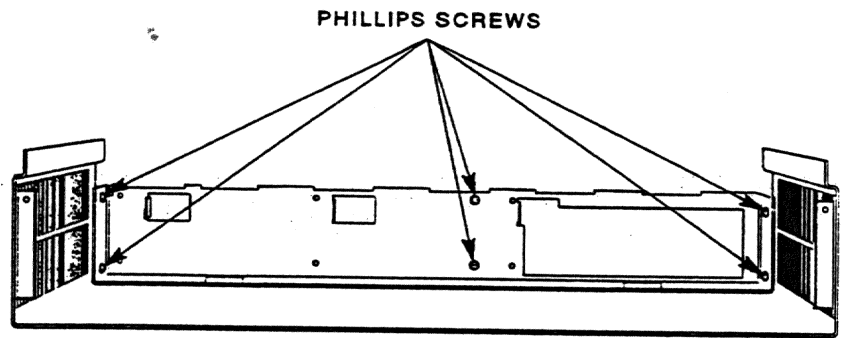

MA-X0517-89

1.6 Installing the Upgrade Label

Install the upgrade label from the kit beside the original label on the back of the system box.

1.7 Reinstalling the System Box Cover

To reinstall the system box cover:

1. Install the system box cover and tighten the two cover screws.
2. Refer to Chapter 1 of the maintenance guide. Run a self-test and the system exerciser to verify the status of the new system module.

1.8 Completing the Installation

The VAXstation 3100 replaced components as well as the excess materials (if any) from the upgrade kit are the property of Digital. You and the customer will need to fill out the upgrade forms in Appendix A and return them to the appropriate locations, as described in Appendix A.

2

Upgrading a Model 30 (No Diskette)

This chapter contains installation procedures for upgrading a VAXstation 3100 model 30 system without a diskette drive to a VAXstation 3100 model 38 system without a diskette drive.

2.1 PV11U-CA Kit Contents

The following table lists the contents and part numbers of the PV11U-CA kit:

Kit Item	Part Number
KA42-BA system module	54-19356-01
Owners manual, network guide, site planning	EK-VSM30-DK
VAXstation 3100 Upgrade Installation Guide	EK-345AA-IN
Upgrade label	36-15946-01
Power supply caution label	36-20124-01
Medallion, VAXstation 3100 M 38	
Three power supply safety screws (one screw is extra)	12-30934-01
Drive plate, MSC module, 4 cables	70-26723-01
Thirteen screw/grommets (6-32) (RZ22/RZ23 mounting screws/grommets, four per drive)	12-31734-01
Only Used if a TZ30 Tape Drive is Installed:	
Five screw/grommets*(metric M3)	12-31734-02
Bezel insert for the TZ30 tape drive	74-37501-01
TZ30 plate	74-39199-01

*TZ30 mounting screws/grommets, one screw is extra.

Kit Item	Part Number
Two TZ30 plate mounting screws	90-09984-07

2.2 Preparing the System for Installation

To prepare the system for installation:

Shut Down the System

1. Shut down the system software.
2. Run a self-test to verify the operation of the present configuration.

```
>>> TEST F 1
```

3. Turn the system power switch off.

Open the System Box

CAUTION

Wear a static wrist strap and use a static mat (PN 29-26242-00) when replacing FRUs.

18 Upgrading a Model 30 (No Diskette)

1. Unscrew the two cover screws.

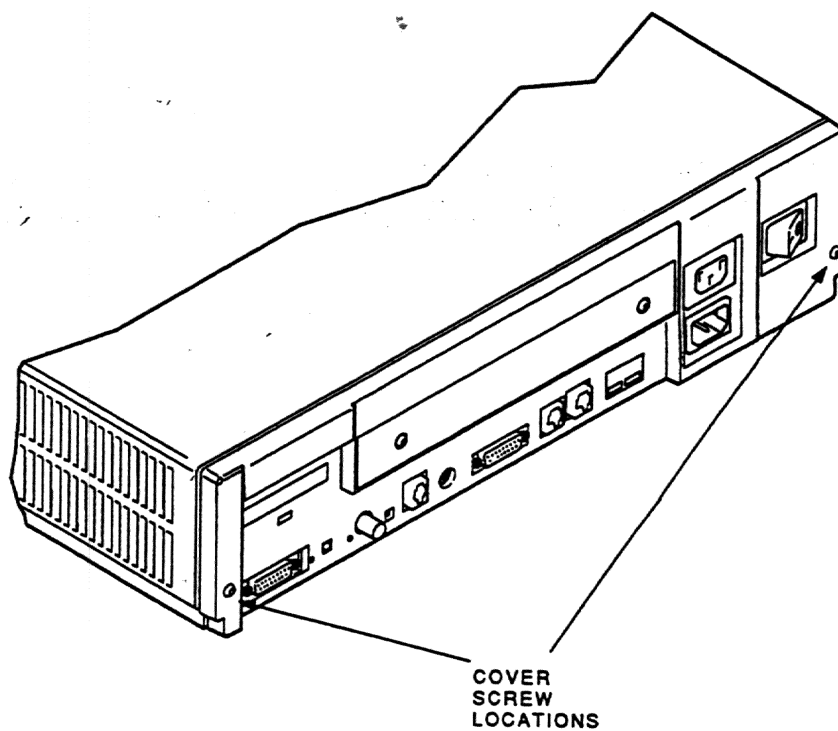

MA-X0796-88

2. Slide the cover forward and up off the system box.

Remove the Drive Mounting Plate

1. Disconnect the power cable from the power supply and disconnect the cable on the mass storage controller (MSC) module that goes to the system module.

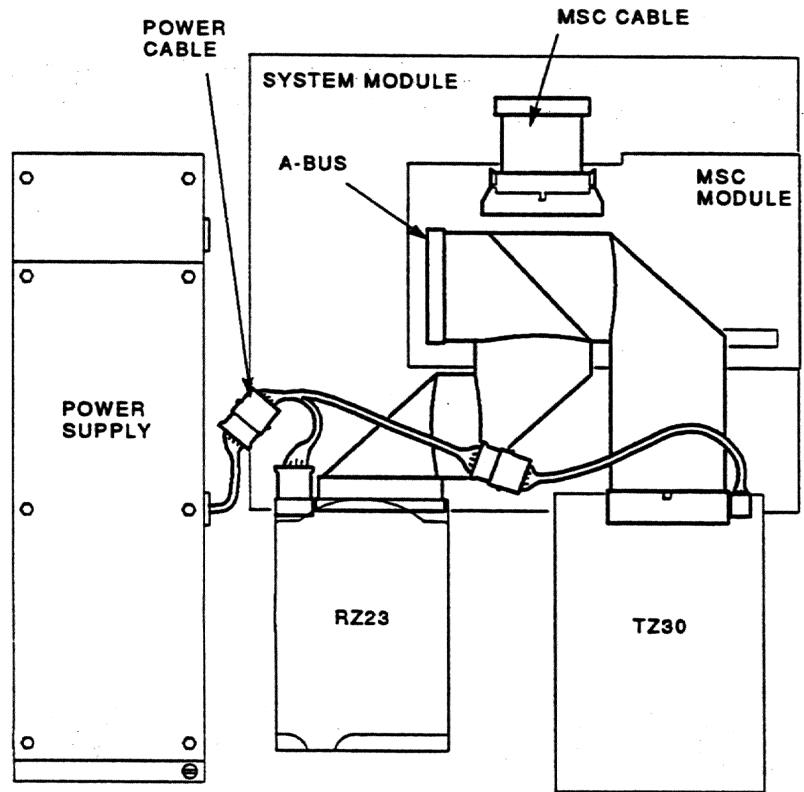

MA-X1172-88

2. Disconnect the external SCSI cable or the terminator from the SCSI port.

20 Upgrading a Model 30 (No Diskette)

3. Unscrew the four captive screws, loosen the three panhead screws, and remove the drive mounting plate.

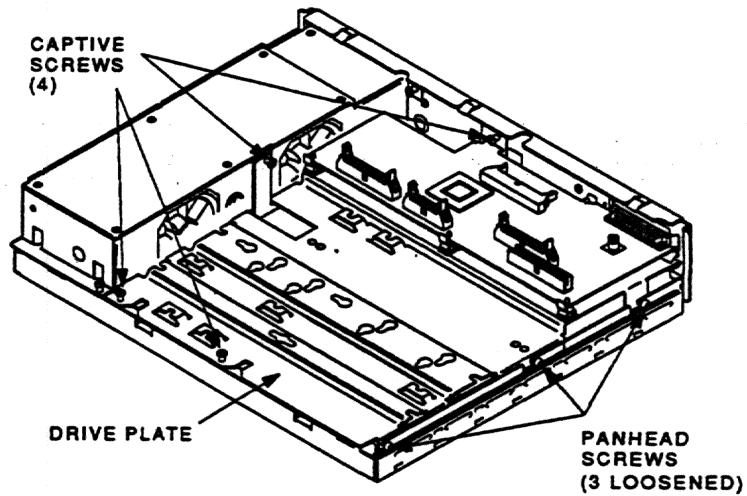

MA-X0527-89A

Remove the Drives from the Drive Plate

1. Disconnect all cables from all drives on the old drive mounting plate and set them aside. They will not be reused.
2. Remove all drives from the old drive mounting plate. The mounting screws and their grommets will not be reused.

Remove the Memory Module

Remove the memory module from the four standoffs, then lift the memory module off the system module. Two connectors will disconnect as you lift the module.

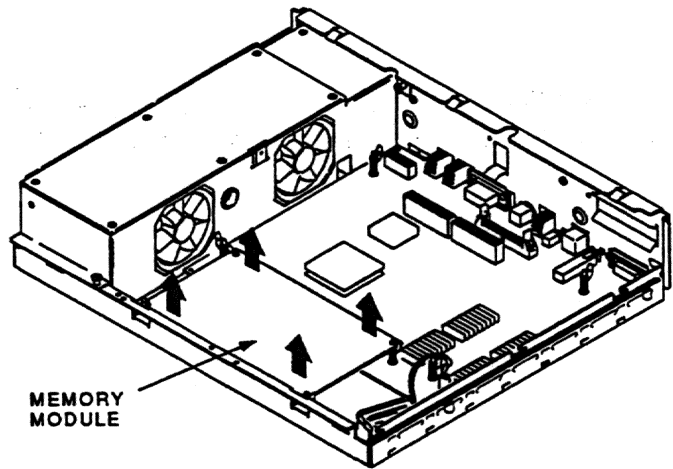

MA-X0804-88

Remove the Graphic Module (if present)

Remove the graphic module from the four standoffs, then lift the graphic module off the system module. Two connectors will disconnect as you lift the module.

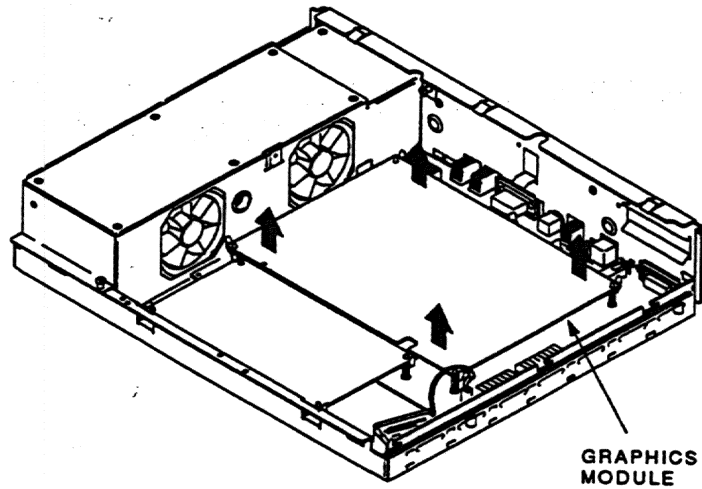

MA-X0803-BB

Remove the System Module

1. Disconnect all cables from the back of the system box.
2. Disconnect the MSC cable from the system module.

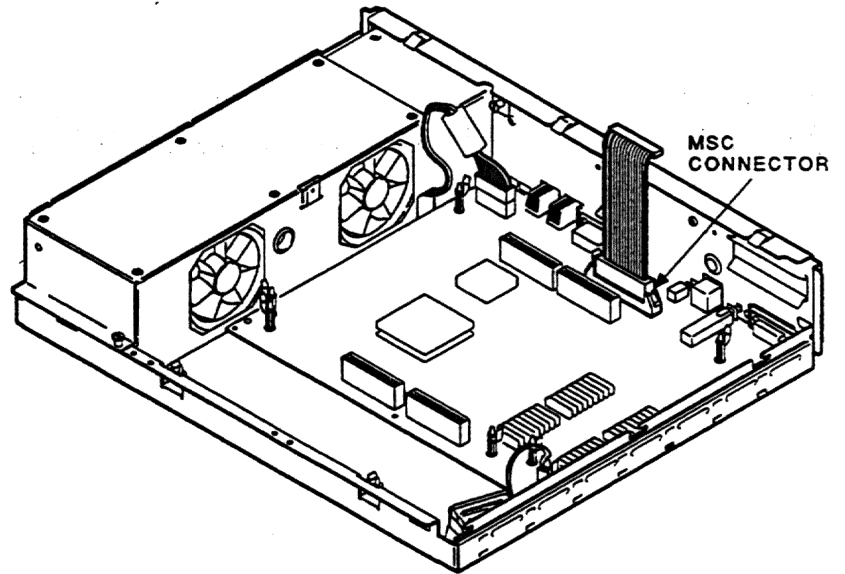

NOTE

Before disconnecting the power cable in the next step, be sure to release the connector latch on the back side of the power connector.

3. Disconnect the power cable and the battery cable from the system module.

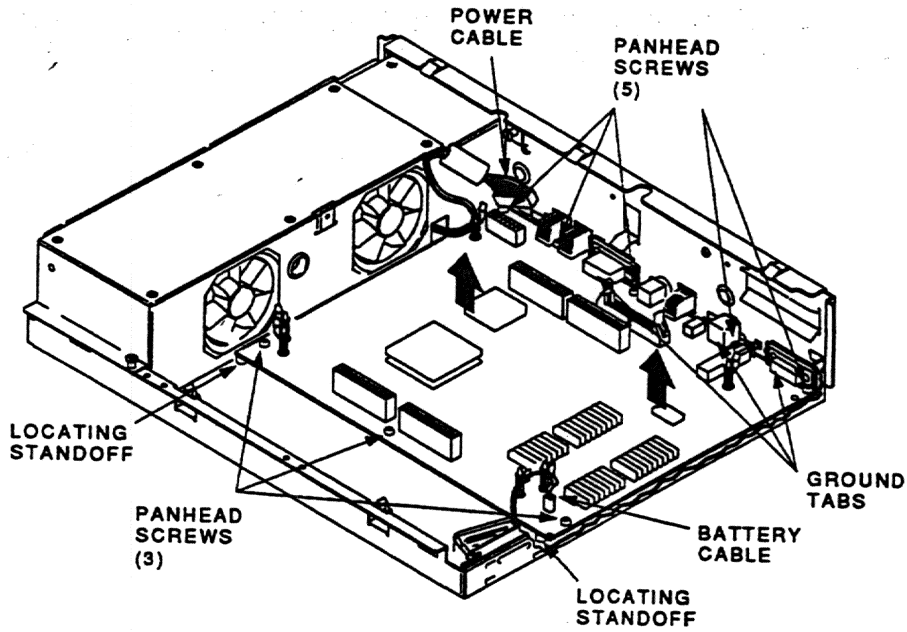

MA-X0805-88

4. Remove the eight screws from the system module.
5. Remove the system module by carefully popping off the two front corners of the two locating standoffs.

CAUTION

In the next step, you will swap the Ethernet ID ROMs on both the new system module and the old system module that you just removed. Be careful not to bend the pins on the ROM or not to mix up the ROM that goes on each system module.

6. Remove the Ethernet ID ROM from the system module you just removed. Set the ROM aside.

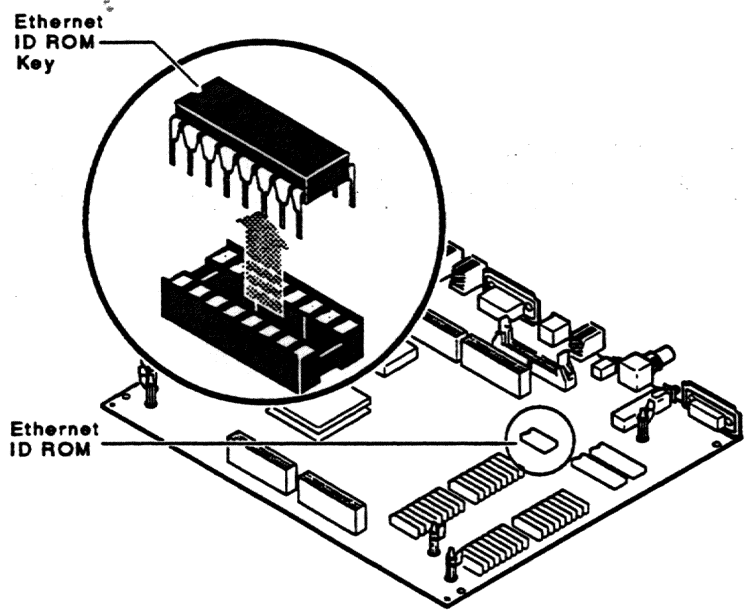

MLO-002918
MA-X0872-80

7. Remove the Ethernet ID ROM from the new system module in the kit and reinstall it on the old system module.
8. Take the ID ROM that you just removed from the old system module and install it on the new system module.

2.3 Installing the Modules

To install the modules:

Install the New System Module

NOTE

When installing the new system module, install the connector end first through the openings in the rear of the box. Push the module back to load the connector ground tabs. Snap the module on both locating standoffs. All screw holes will then be aligned.

1. Check the position of the S3 switch next to the LEDs on the back of the system module. Be sure S3 is in the down position. The down position enables the monitor to be the console, and the up position enables a terminal connected to the printer port to be the console.
2. Install the connector end of the system module first through the openings in the rear of the box. Push the module back to load the connector ground tabs, then snap the module on both locating standoffs. All screw holes will then be aligned.

3. Install the eight screws on the system module.

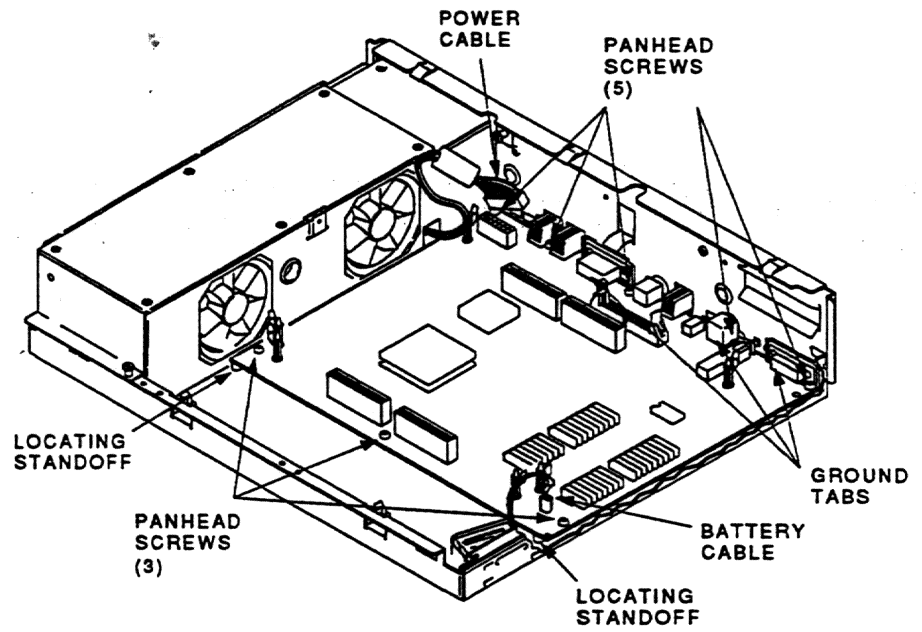

MA-X0805-88A

4. Connect the power cable and the battery cable to the system module.
5. Reconnect all cables to the back of the system box.

Reinstall the Memory Module

Install the memory module(s) on the new system module as shown in the following two figures. The first figure is for 4 or 12 Mbyte (single) memory module; the second figure is for 8 or 16 Mbyte (dual) memory module. After the module(s) are installed, press down on top of the module's connectors to firmly seat the connectors.

4 or 12 Mbyte (single) Memory Module Installation

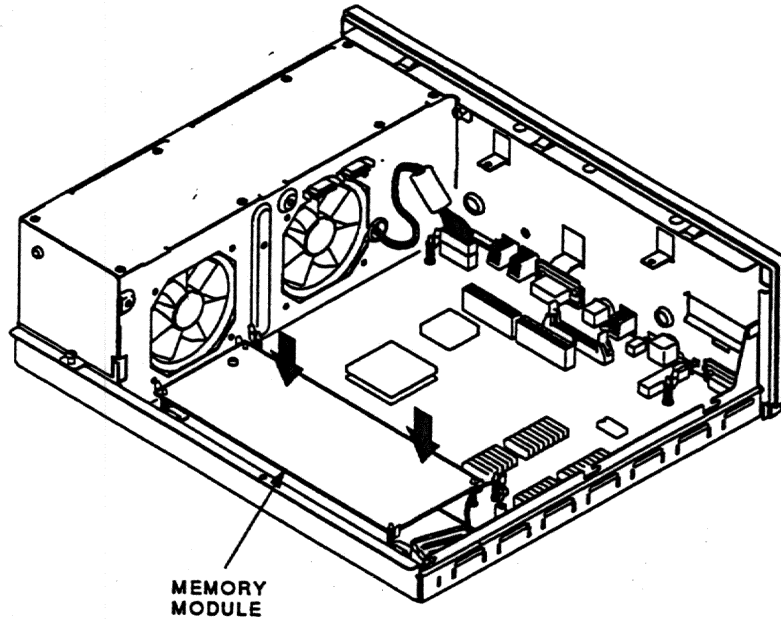

MA-X0848-88A

8 or 16 Mbyte (dual) Memory Module Installation

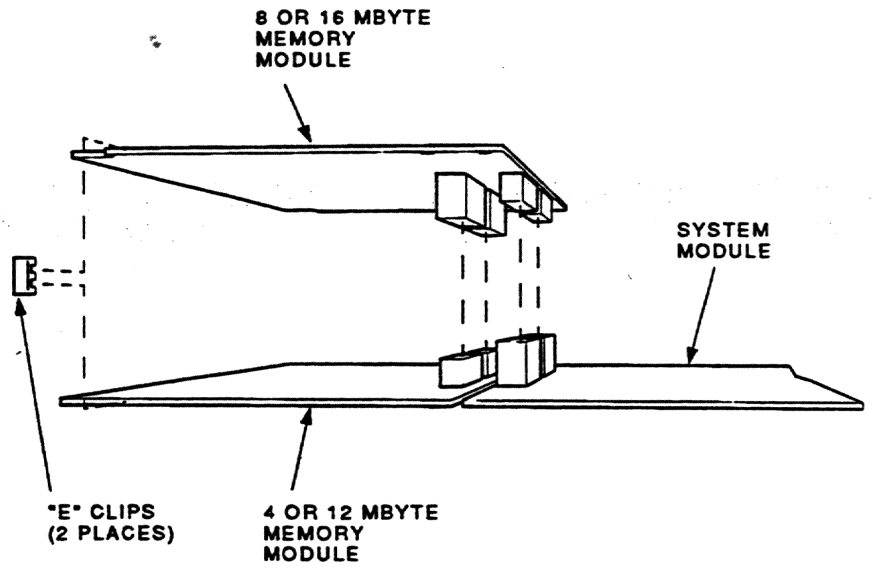

MA-X1174-88A

Reinstall the Graphic Module (if present)

Reinstall the graphics module on the new system module. After the module is installed, press down on top of the module's connectors to firmly seat the connectors.

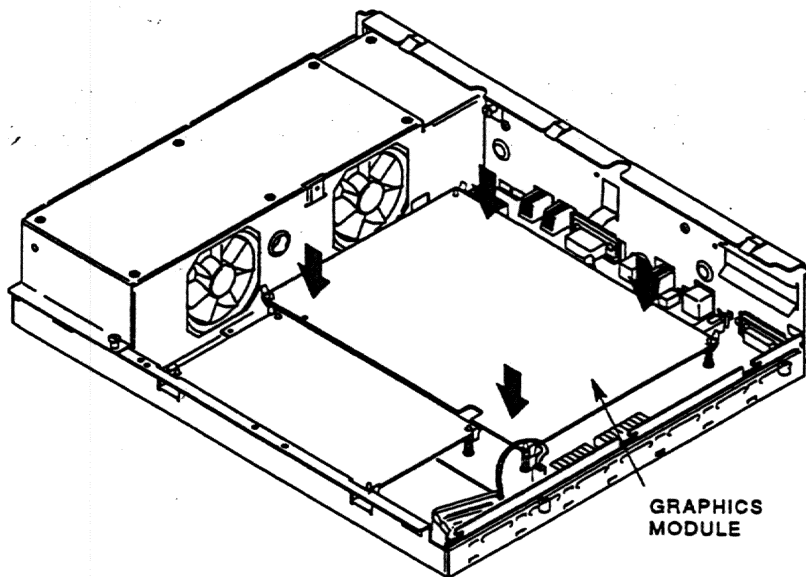

MA-X0803-88A

2.4 Installing the New Drive Plate

To install the new drive plate:

1. Connect the MSC cable to the new system module.

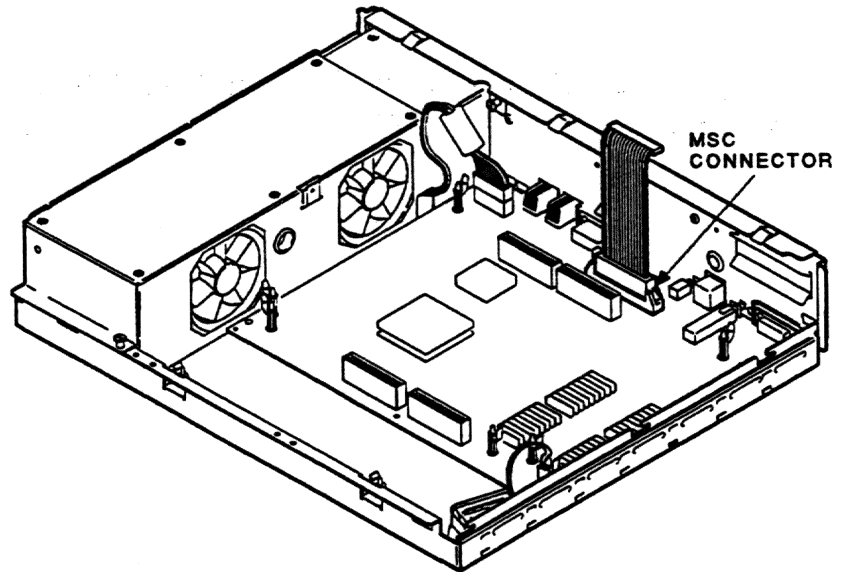

32 Upgrading a Model 30 (No Diskette)

2. Loosen the three slide mount screws on the side of the new drive plate.
3. Remove the SCSI terminator from the MSC module on the drive plate.
4. Position the drive plate on the system box, making sure that the MSC cable is not trapped under the drive plate.

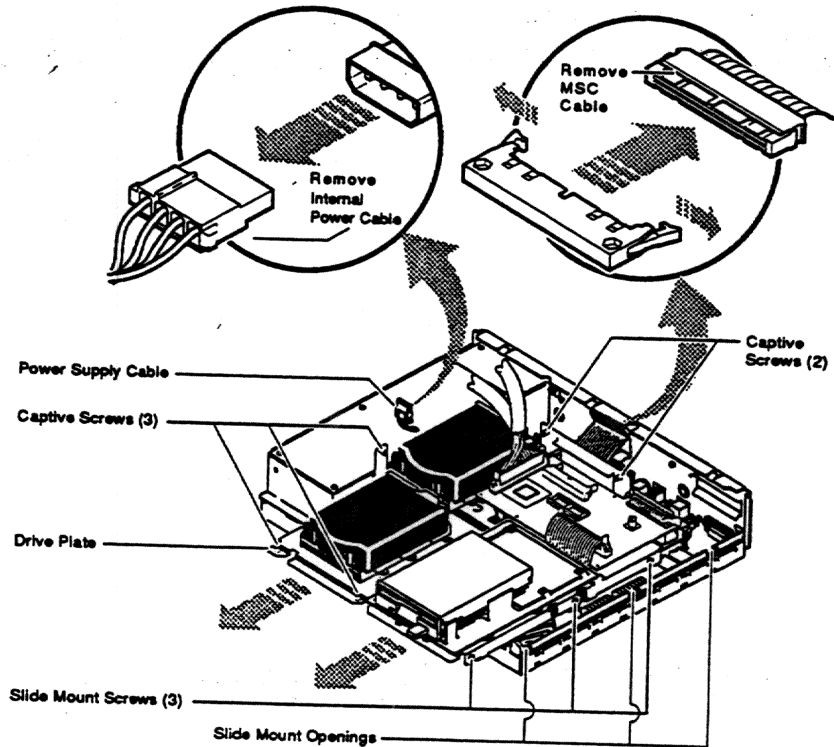

MLO-002905
MA-X0863-89

5. Tighten the five captive screws, then tighten the three slide mount screws.
6. Connect the MSC cable to the MSC module.

2.5 Configuring the Drives on the New Drive Plate

Determine where you will install the drives on the drive plate as follows:

If	Then
You are reinstalling one RZ22/RZ23 drive with the TZ30 tape drive	the RZ22/RZ23 should be in position 3 with the TZ30 in position 2.
You are reinstalling two RZ22/RZ23 drives with the TZ30 tape drive	the RZ22/RZ23s should be in position 3 and 4 with the TZ30 in position 2.
You are reinstalling three RZ22/RZ23 drives with no TZ30 tape drive	the RZ22/RZ23s should be in position 2, 3, and 4.

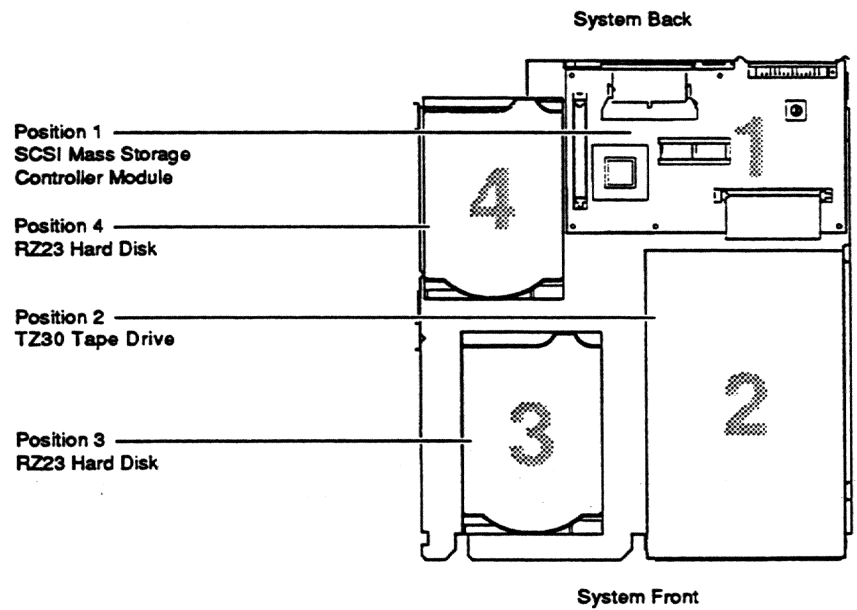

MLO-002894
MA-X0859-89

34 Upgrading a Model 30 (No Diskette)

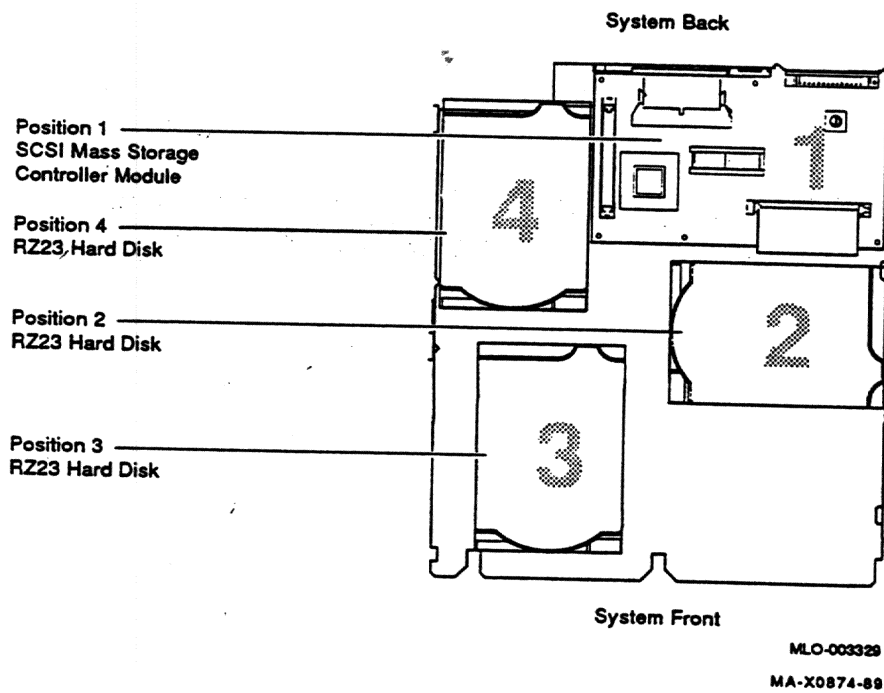

2.6 Installing the RZ22/RZ23 Disk Drive(s)

To install the RZ22/RZ23 disk drive(s):

Mount the Drives

1. Install four screw/grommets (PN 12-31734-01) on the bottom of the RZ22/RZ23 drive.

2. Insert the drive (with the power connector towards the front) on the four keyhole slide mount openings in its proper position on the drive plate.

NOTE

If you are mounting a drive in position 4, you need to remove the MSC module for access to the drive's mounting holes.

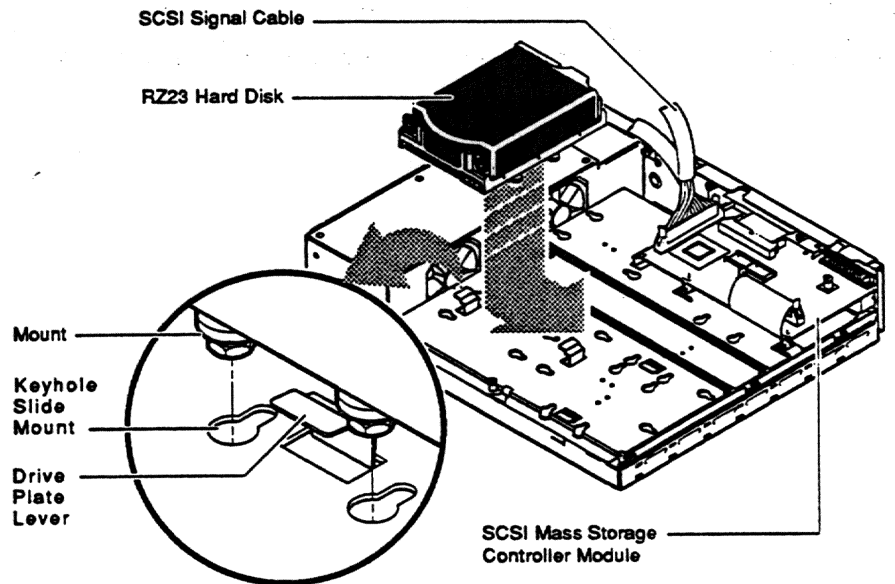

MLO-002896
MA-X0860-89

3. Press the RZ23 hard disk down and slide it in the keyhole slide mount openings to lock it on the drive plate. The drive plate lever should pop up to lock the drive in place.
4. Repeat steps 1 through 3 for each drive that needs to be installed.

Cable the Drives

The following figure shows the five connectors of the new power cable from the kit. The connectors are numbered for reference.

1. Connect the male connector ② to the power supply.

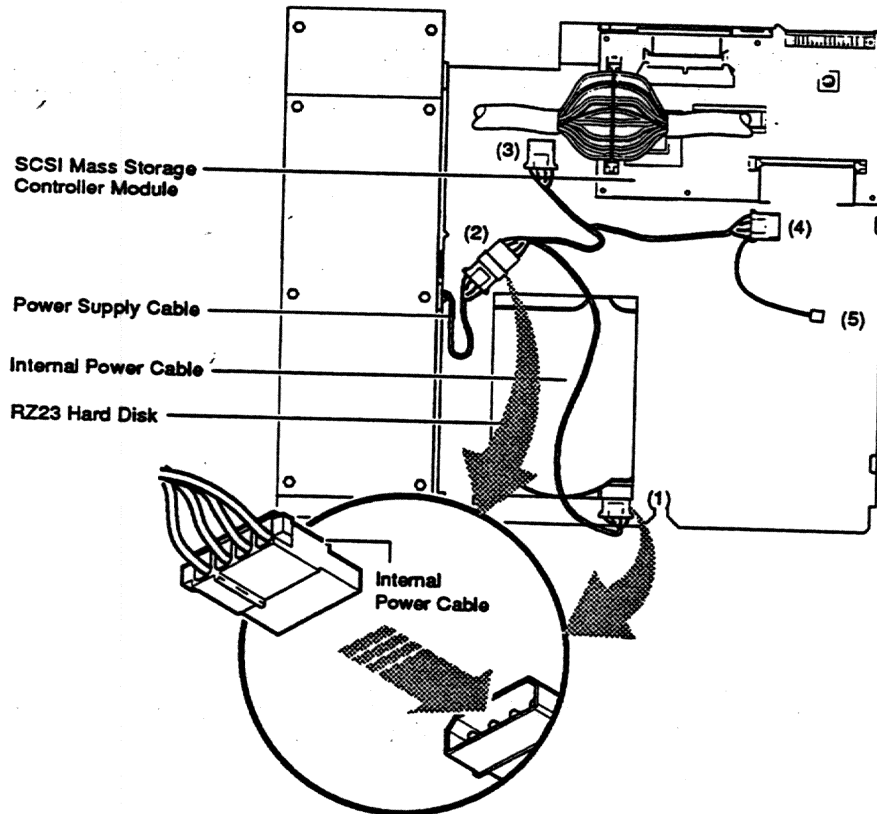

MLG-002987
MA-X0861-89

2. Connect the other ends of the power cable to the RZ23 hard disk drives ①, ③, or ④ depending on the position of the drives.

3. If the larger (100 pin) end of the SCSI signal cable is not already connected to the SCSI port A on the MSC module, then connect it now.

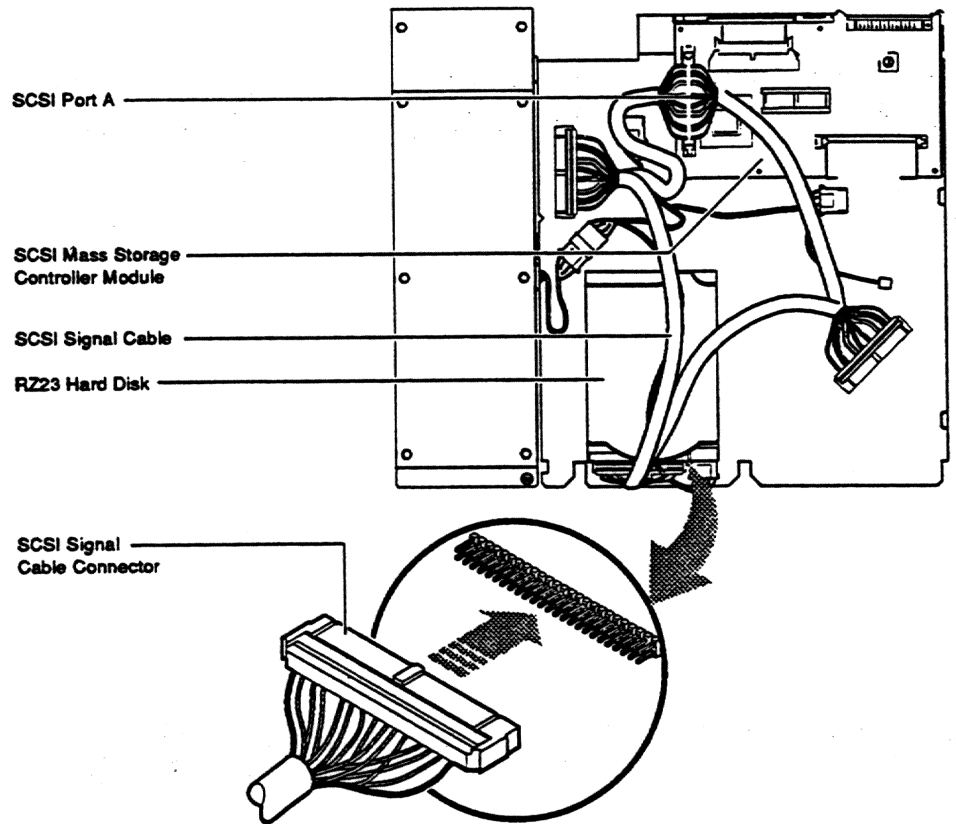

MLC-002898
MA-X0862-89

4. Connect the SCSI signal cable (PN 17-02439-01) to the RZ23 hard disk drives.

2.7 Installing the TZ30 Tape Drive

To install the TZ30 tape drive:

Mount the Drive

1. Install four metric screw/grommets (PN 12-31734-02) on the bottom of the TZ30 tape drive.
2. Install the TZ30 plate on the left side of the drive, using one of the two TZ30 plate mounting screws.

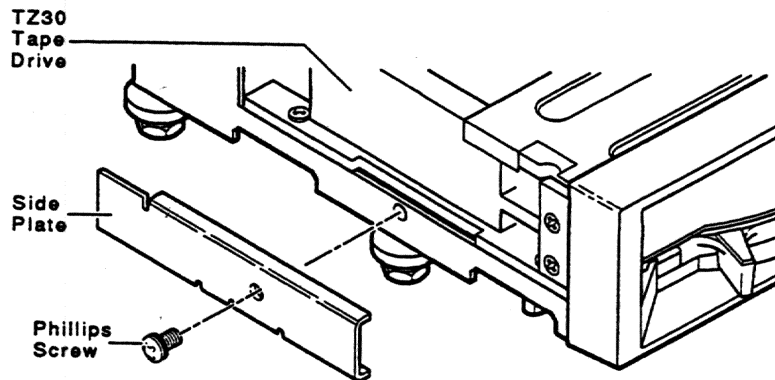

MLD-003477
MA-X0934-89

3. Tuck the SCSI B port terminator cable under the MSC module. This cable terminates the SCSI B port and does not connect to any internal drives.

4. Insert the TZ30 tape drive on the four keyhole slide mount openings on the drive plate.

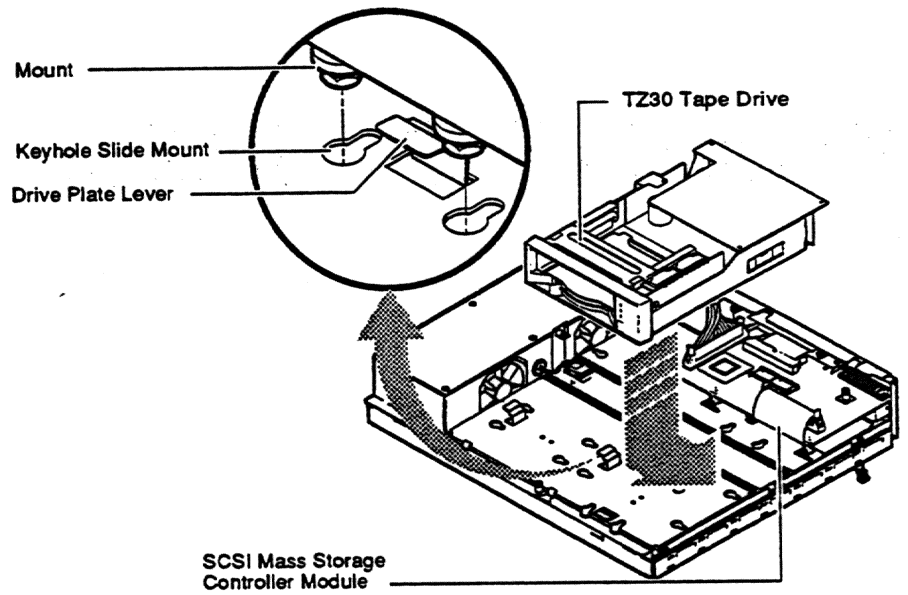

MLO-002891

MA-X0856-89

5. Press the TZ30 tape drive down and slide it in the keyhole slide mount openings to lock it on the drive plate. The drive plate lever should pop up to lock the drive in place.

Cable the Drive

1. If you have not already connected the power cable's male connector ② to the power supply in the previous section, then connect it now.
2. Connect the number ④ connector on the power cable to the TZ30 tape drive.

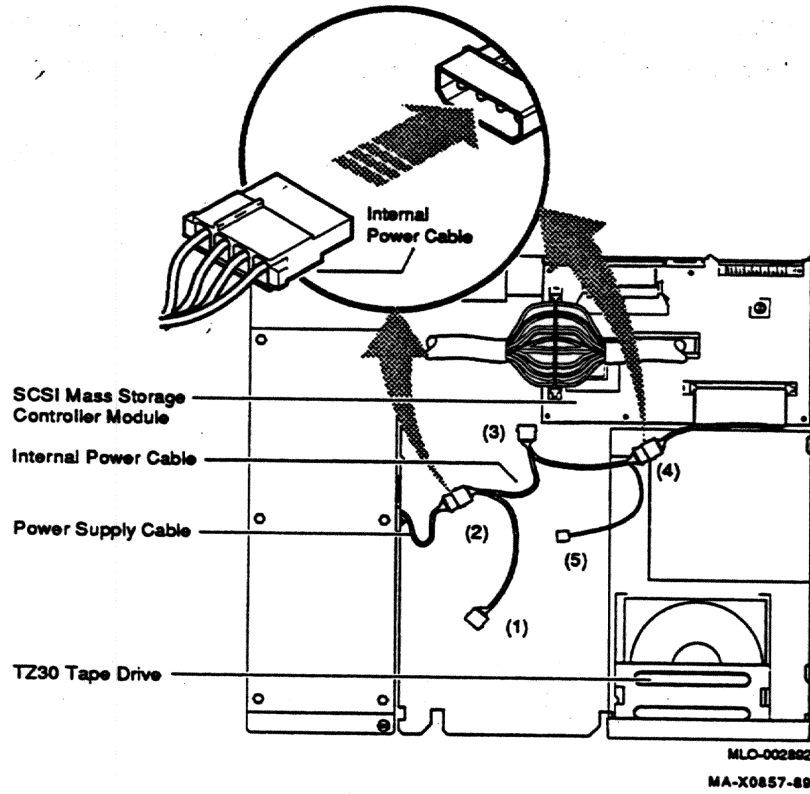

3. Connect the SCSI signal cable (PN 17-02439-01) to the TZ30 tape drive.

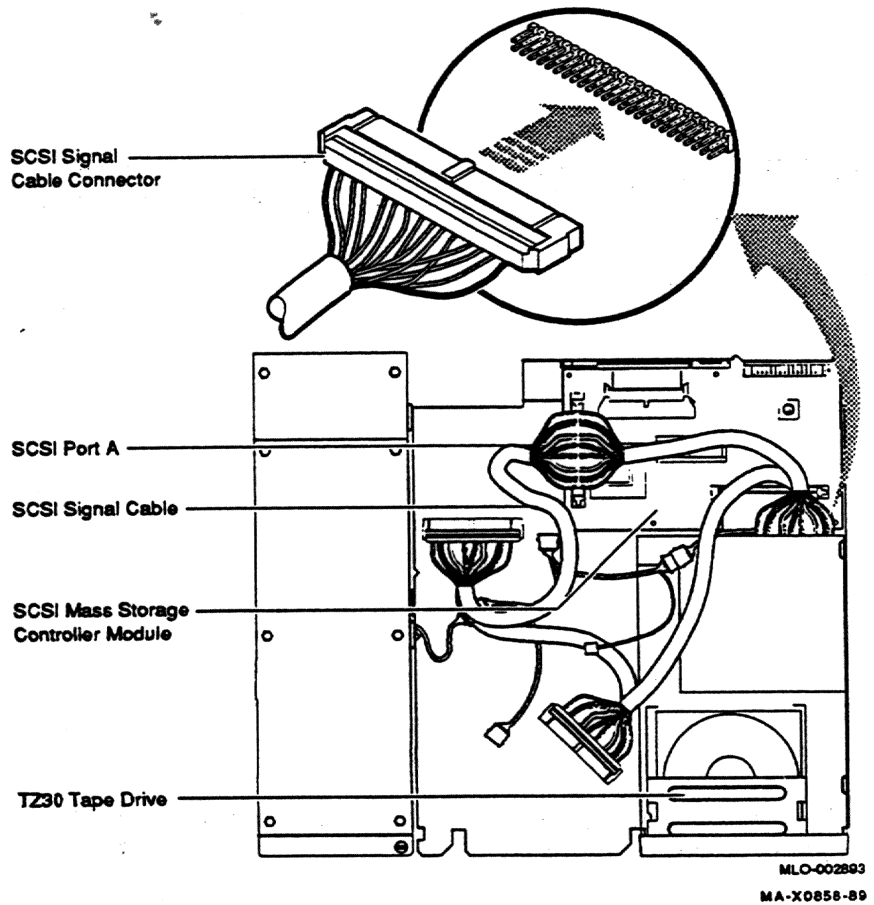

4. If the SCSI signal cable is not already connected to the SCSI port A on the MSC module, then connect it now.

Install the New Bezel Insert

1. On the cover of the system box, remove the six screws and remove the front bezel from the cover.

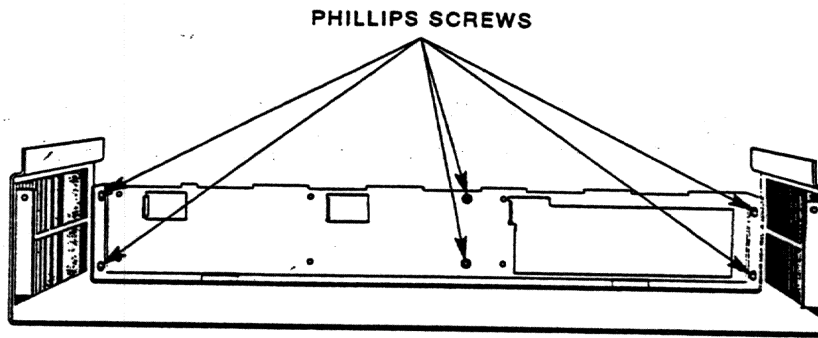

MA-X0517-89

2. Separate the bezel insert from the front bezel.

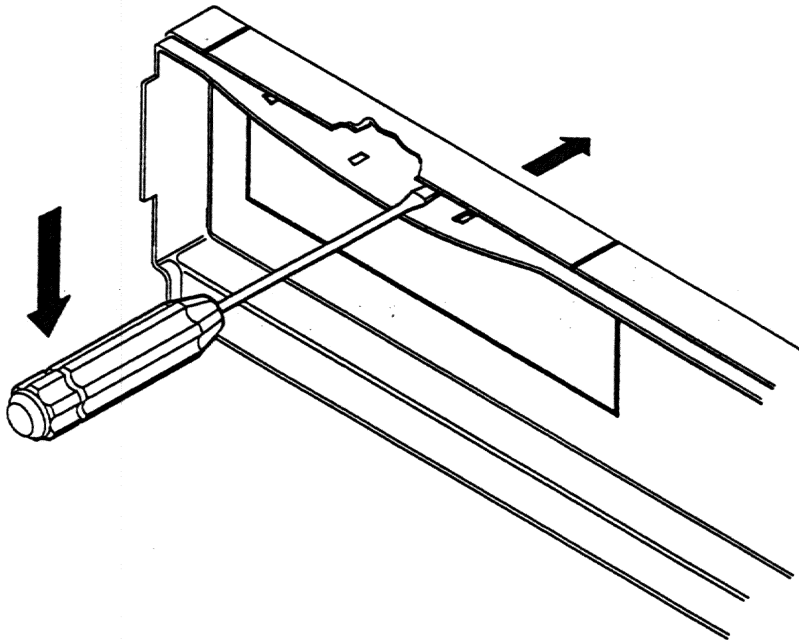

MA-X0518-89

3. Install the new bezel insert from the kit on the front bezel by reversing steps 1 and 2.
4. Remove the VAXstation 3100 medallion from the system box cover.
5. Install the new VAXstation 3100 M 38 medallion from the kit in the cover.
6. Reinstall the front bezel on the cover and reinstall the six screws.

2.8 Replacing the Power Supply Screws

To replace the power supply screws:

1. Remove the two phillips-head screws from the side of the power supply.
2. Install two of the three torx-head power supply safety screws (PN 12-30934-01) from the kit into the side of the power supply using the torx-head screwdriver.

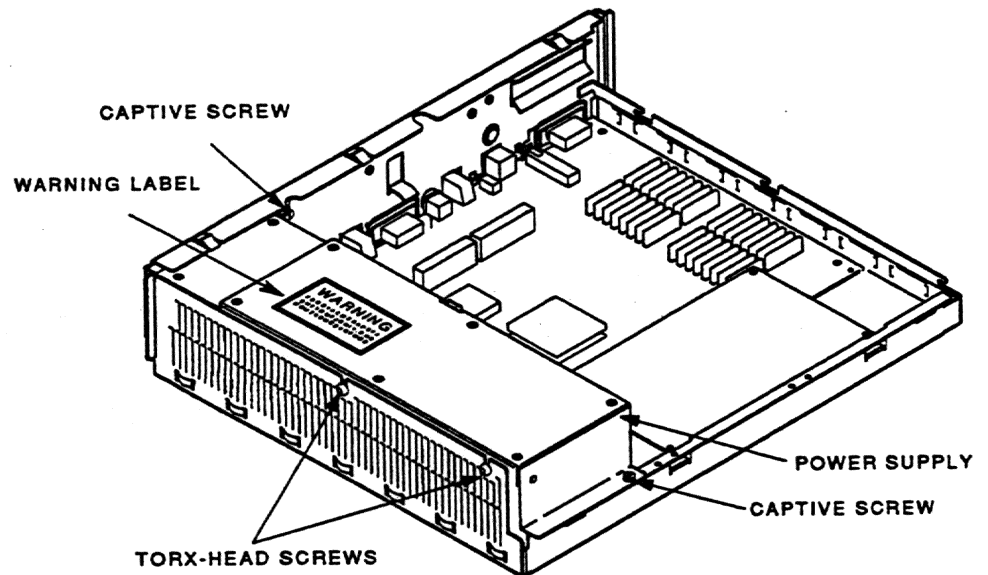

MA-X0808-88A

3. Install the power supply warning label on the power supply.

2.9 Changing the Medallion

Perform the following steps to change the medallion if you have not already changed it.

1. On the cover of the system box, remove the six screws and remove the front bezel from the cover.
2. Remove the VAXstation 3100 medallion from the system box cover.
3. Install the new VAXstation 3100 M 38 medallion from the kit in the cover.
4. Reinstall the front bezel on the cover and reinstall the six screws.

2.10 Installing the Upgrade Label

Install the upgrade label from the kit beside the original label on the back of the system box.

2.11 Reinstalling the System Box Cover

To reinstall the system box cover:

1. Install the system box cover and tighten the two cover screws.
2. Refer to Chapter 1 of the maintenance guide. Run a self-test and the system exerciser to verify the status of the new system module.

2.12 Completing the Installation

The VAXstation 3100 replaced components as well as the excess materials (if any) from the upgrade kit are the property of Digital. You and the customer will need to fill out the upgrade forms in Appendix A and return them to the appropriate locations, as described in Appendix A.

Upgrading a Model 30 (With Diskette)

This chapter contains installation procedures for upgrading a VAXstation 3100 model 30 system that contains a diskette drive to a VAXstation 3100 model 38 system with a diskette drive.

3.1 PV11U-BA Kit Contents

The following table lists the contents and part numbers of the PV11U-BA kit:

Kit Item	Part Number
KA42-BA system module	54-19356-01
Owners manual, network guide, site planning	EK-VSM30-DK
VAXstation 3100 Upgrade Installation Guide	EK-345AA-IN
Upgrade label	36-15946-01
Power supply caution label	36-20124-01
Medallion, VAXstation 3100 M 38	
Three power supply safety screws*	12-30934-01
Drive plate, MSC module, 4 cables	70-26723-01
Thirteen screw/grommets*	12-31734-01
SCSI/FDI module	54-19288-01
Cable, 34 pin flat	17-02221-02
RX23 SCSI adapter module mounting bracket	74-39094-01
Six screws for mounting the SCSI adapter module*	90-09708-00
Five screws for mounting the RX23*	90-10981-01
Front panel window bezel	74-39607-01

*One screw is extra.

Kit Item	Part Number
RX23 bezel	12-32364-01
RX23 eject button	12-32363-01

3.2 Preparing the System for Installation

To prepare the system for installation:

Shut Down the System

1. Shut down the system software.
2. Run a self-test to verify the operation of the present configuration.

>>> TEST F 1

3. Turn the system power switch off.

Open the System Box

CAUTION

Wear a static wrist strap and use a static mat (PN 29-26242-00) when replacing FRUs.

1. Unscrew the two cover screws.

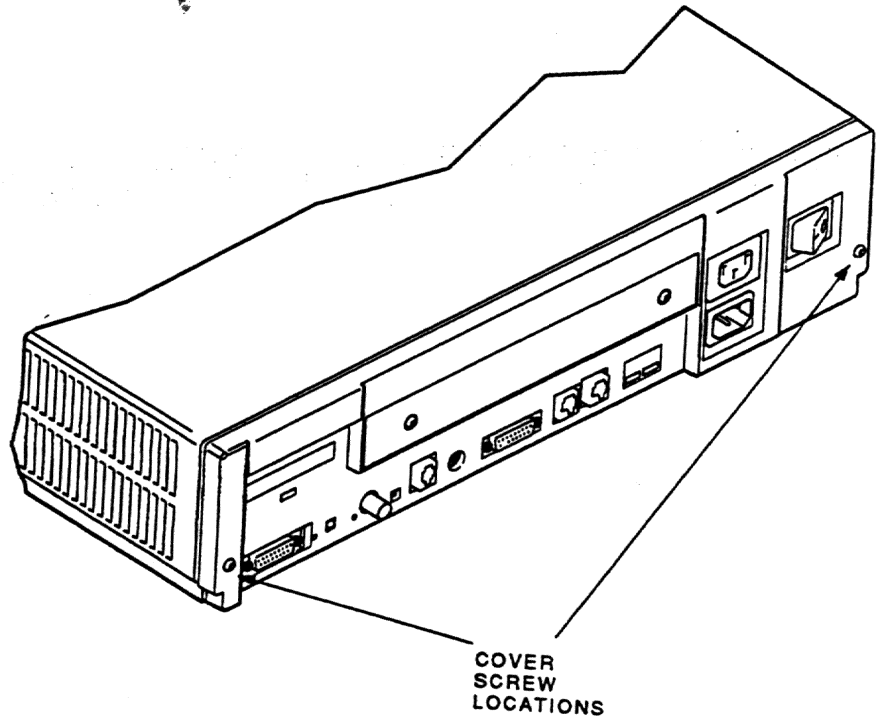

MA-X0796-88

2. Slide the cover forward and up off the system box.

Remove the Drive Mounting Plate

1. Disconnect the power cable from the power supply and disconnect the cable on the mass storage controller (MSC) module that goes to the system module.

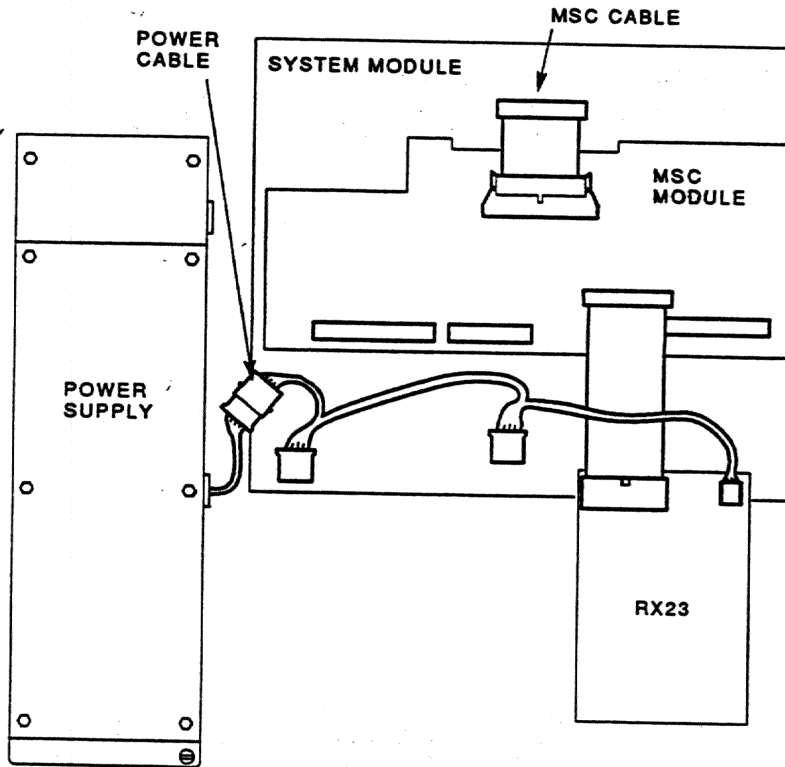

MA-X0526-89

2. Disconnect the external SCSI cable or the terminator from the SCSI port.

3. Unscrew the four captive screws, loosen the three panhead screws, and remove the drive mounting plate from the system box.

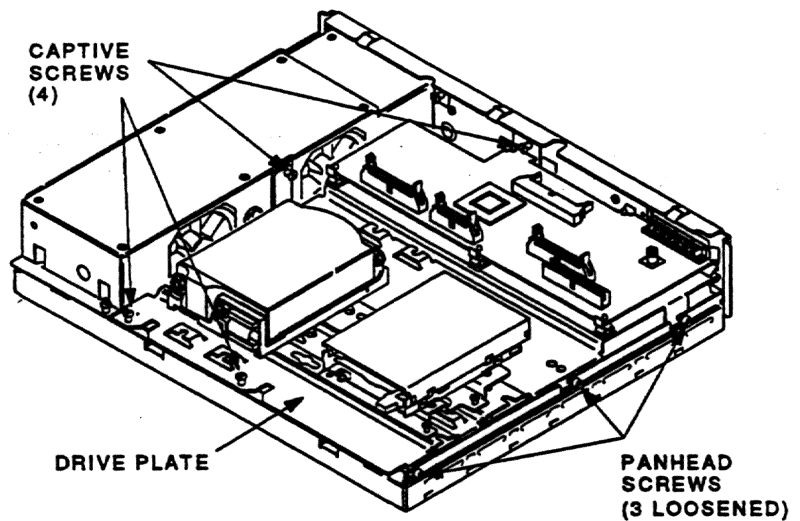

MA-X0858-88

Remove the Drives from the Drive Plate

1. Disconnect all cables from all of the drives on the old drive mounting plate and set them aside. They will **not** be reused.
2. Remove all of the drives from the old drive mounting plate. The mounting screws and their grommets will **not** be reused.

Remove the Memory Module

Remove the memory module from the four standoffs, then lift the memory module off the system module. Two connectors will disconnect as you lift the module.

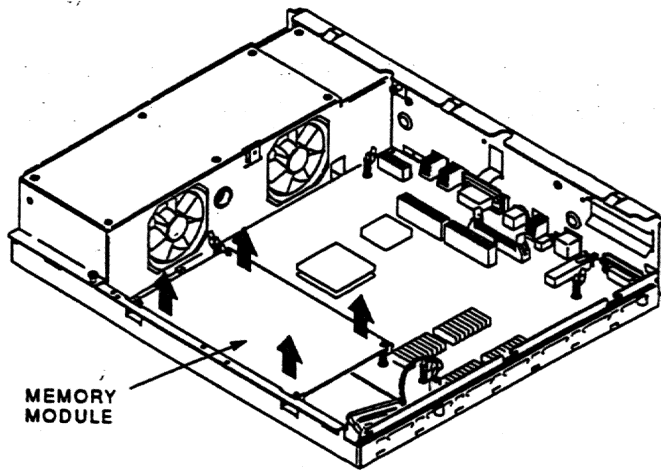

MA-X0804-88

Remove the Graphic Module (If present)

Remove the graphic module from the four standoffs, then lift the graphic module off the system module. Two connectors will disconnect as you lift the module.

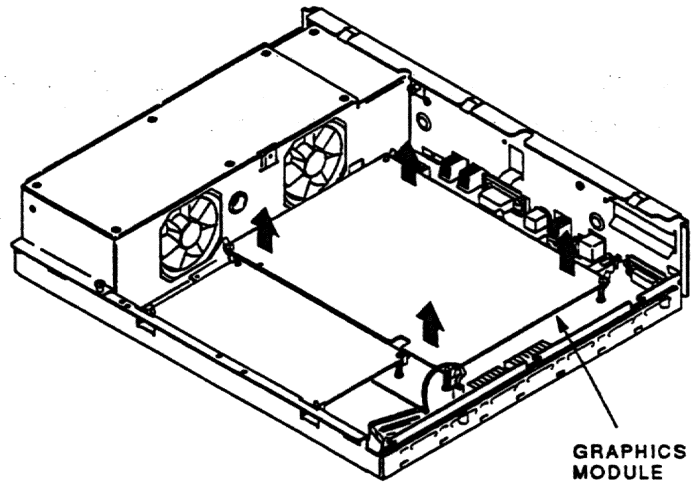

GRAPHICS
MODULE

MA-X0803-88

Remove the System Module

To remove the system module:

1. Disconnect all cables from the back of the system box.
2. Disconnect the MSC cable from the system module.

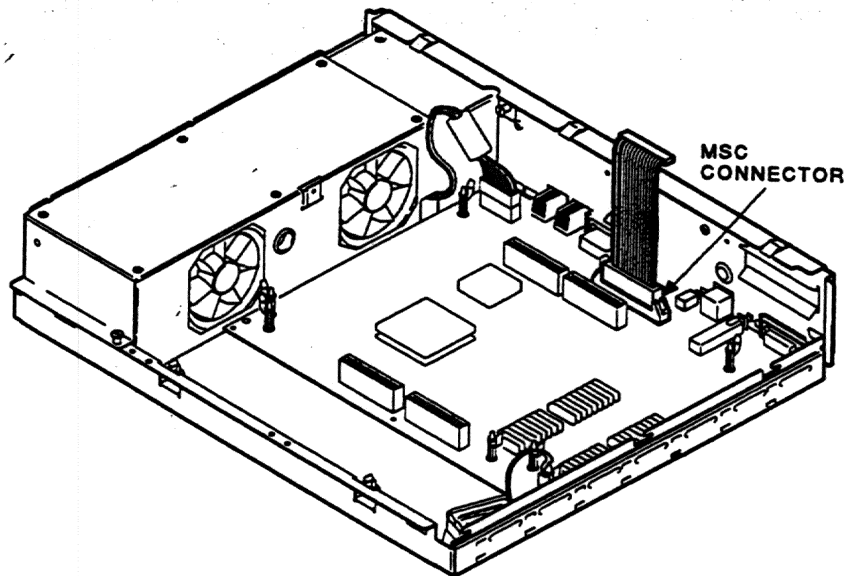

NOTE

Before disconnecting the power cable in the next step, be sure to release the connector latch on the back side of the power connector.

3. Disconnect the power cable and the battery cable from the system module.

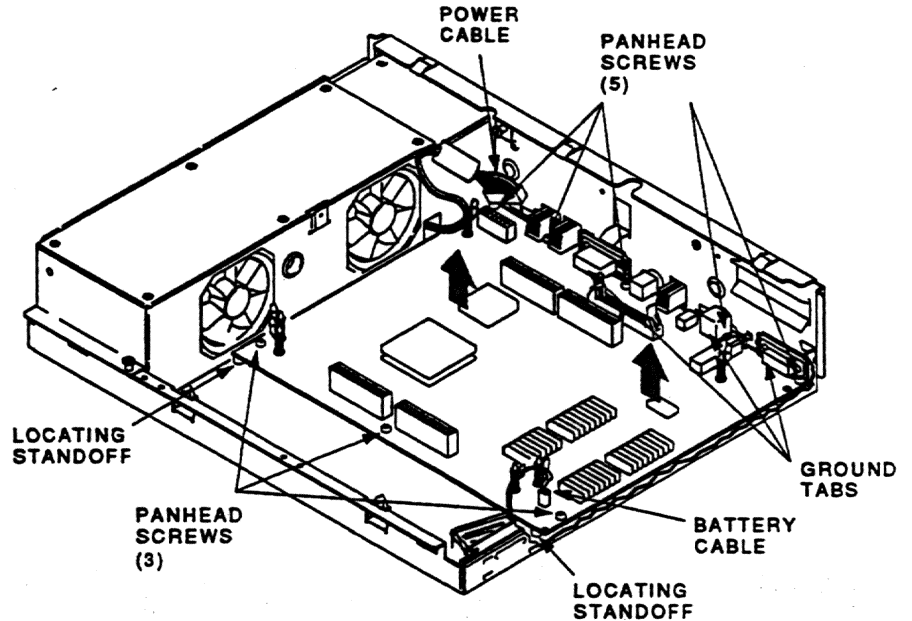

MA-X0805-88

4. Remove the eight screws from the system module.
5. Remove the system module by carefully popping off the two front corners of the two locating standoffs.

CAUTION

In the next step, you will swap the Ethernet ID ROMs on both the new system module and the old system module that you just removed. Be careful not to bend the pins on the ROM or not to mix up the ROM that goes on each system module.

6. Remove the Ethernet ID ROM from the system module you just removed. Set the ROM aside.

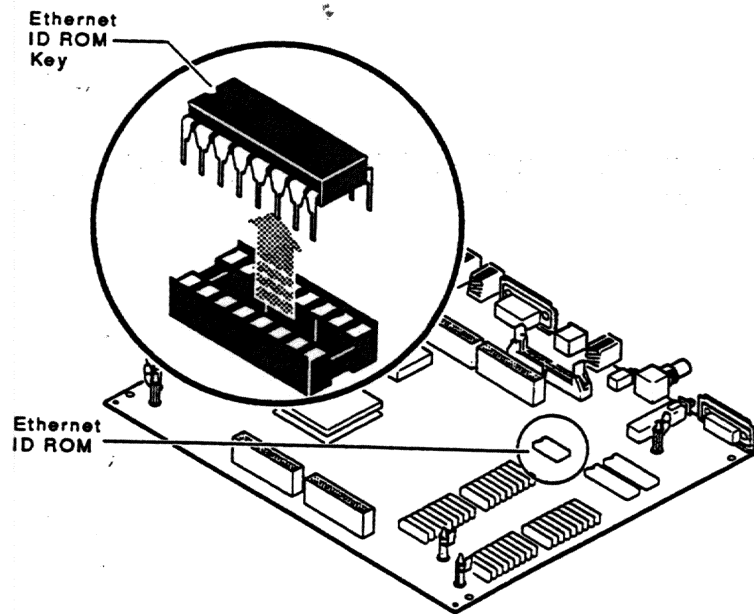

MLO-002918
MA-X0872-89

7. Remove the Ethernet ID ROM from the new system module in the kit and reinstall it on the old system module.
8. Take the ID ROM that you just removed from the old system module and install it on the new system module.

3.3 Installing the Modules

To install the modules:

Install the New System Module

NOTE

When reinstalling the system module, install the connector end first through the openings in the rear of the box. Push the module back to load the connector ground tabs. Snap the module on both locating standoffs. All screw holes will then be aligned.

1. Check the position of the S3 switch next to the LEDs on the back of the system module. Be sure S3 is in the down position (the down position enables the monitor to be the console and the up position enables a terminal connected to the printer port to be the console).
2. Install the connector end of the system module first through the openings in the rear of the box. Push the module back to load the connector ground tabs, then snap the module on both locating standoffs. All screw holes will then be aligned.
3. Install the eight screws on the system module.

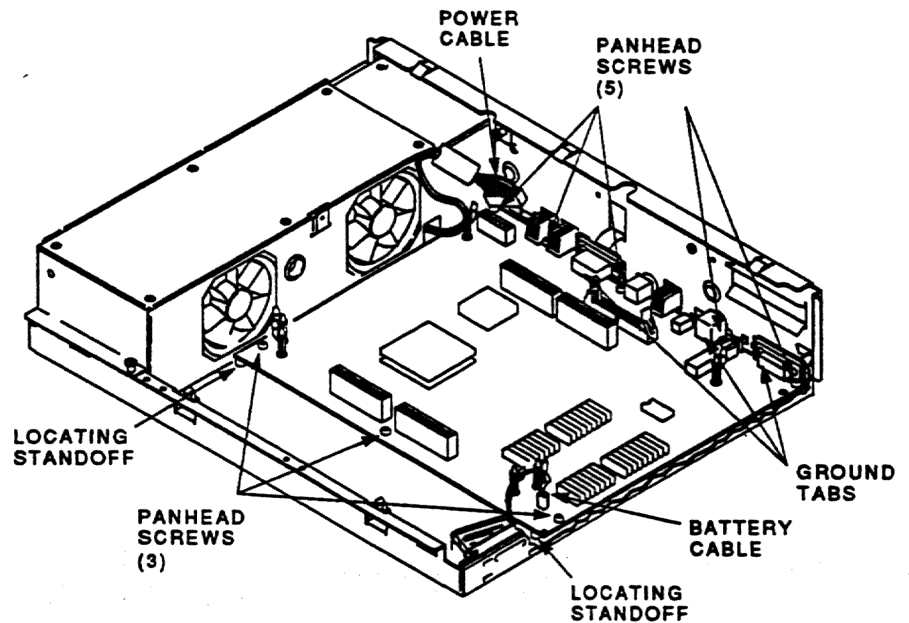

MA-X0805-88A

4. Connect the power cable and the battery cable to the system module.
5. Reconnect all cables to the back of the system box.

Reinstall the Memory Module

Install the memory module(s) on the new system module as shown in the following two figures. The first figure is for 4 or 12 Mbyte (single) memory module installation; the second figure is for 8 or 16 Mbyte (dual) memory module installation. After the module(s) are installed, press down on top of the module's connectors to firmly seat the connectors.

4 or 12 Mbyte (single) Memory Module Installation

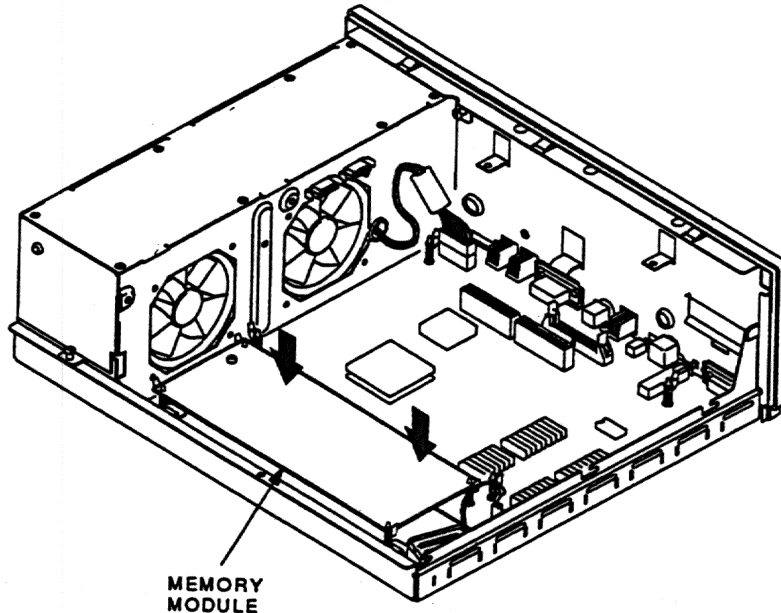

MA-X0848-88A

8 or 16 Mbyte (dual) Memory Module Installation

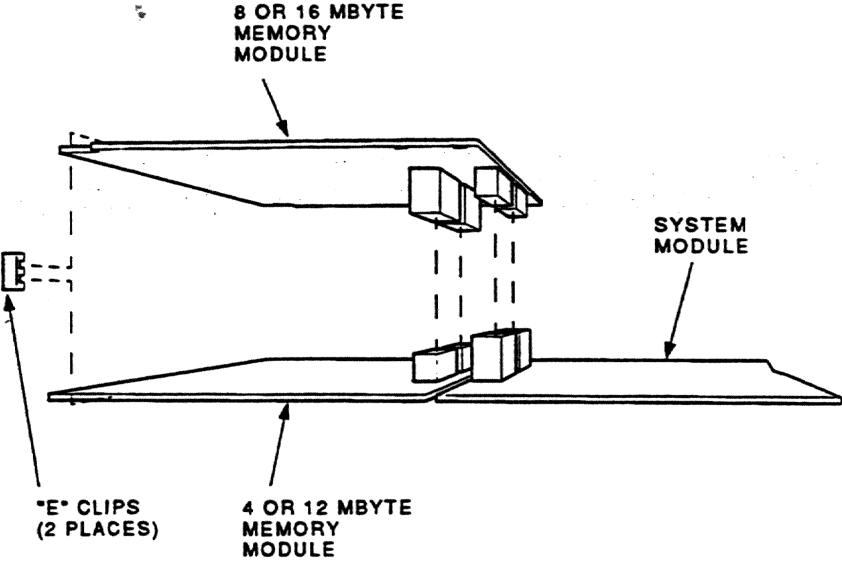

MA-X1174-88A

Reinstall the Graphic Module (If present)

Reinstall the graphics module on the new system module as shown in the following figure. After the module is installed, press down on top of the module's connectors to firmly seat the connectors.

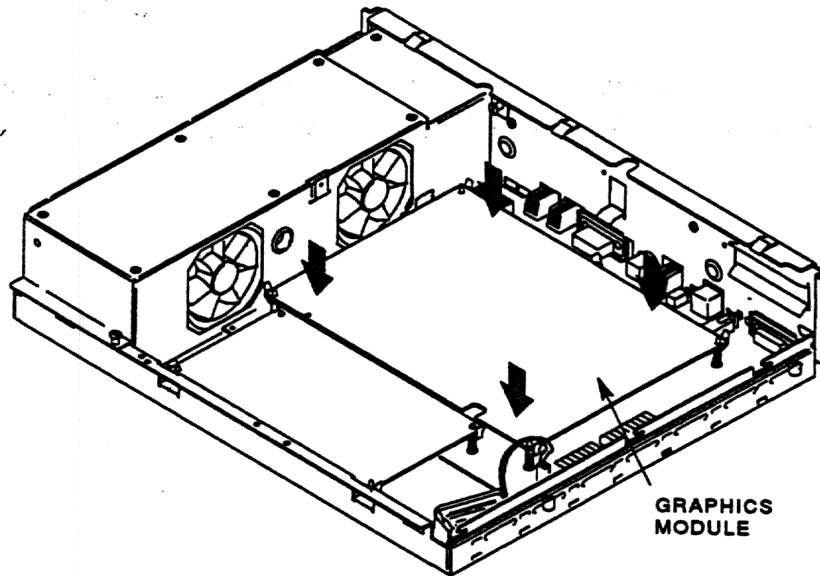

MA-X0803-88A

3.4 Installing the New Drive Plate

To install the new drive plate:

1. Connect the MSC cable to the new system module.

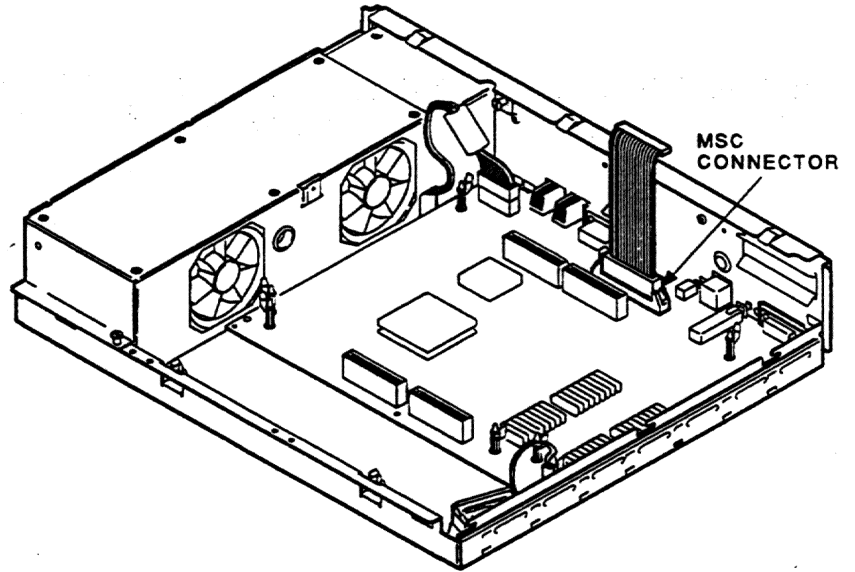

60 Upgrading a Model 30 (With Diskette)

2. Loosen the three slide mount screws on the side of the drive plate.
3. Remove the SCSI terminator from the MSC module on the drive plate.
4. Position the drive plate on the system box making sure that the MSC cable is not trapped under the drive plate.

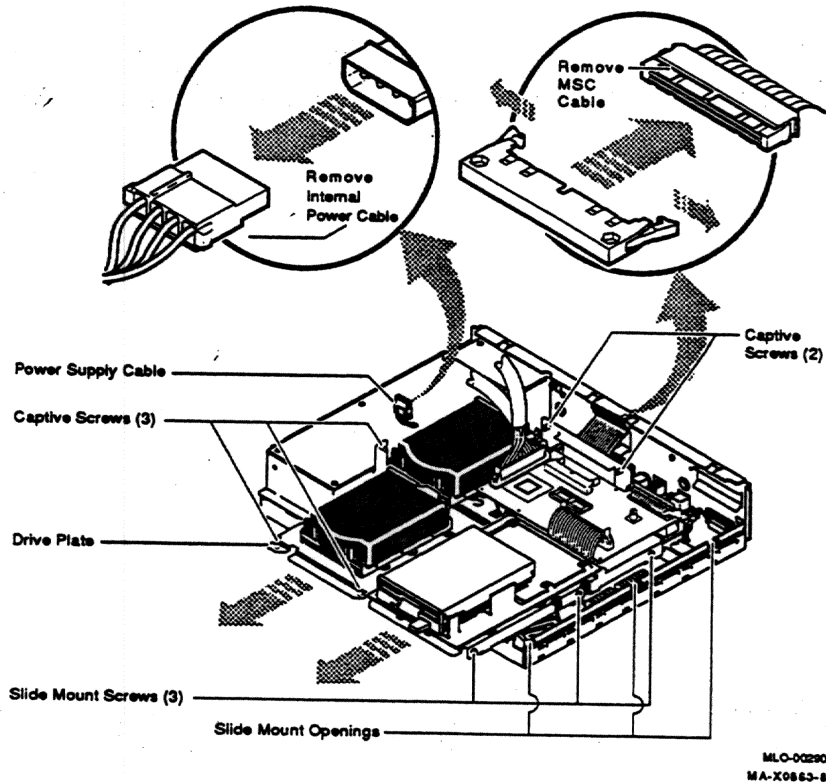

5. Tighten the five captive screws, then tighten the three slide mount screws.
6. Connect the MSC cable to the MSC module.

3.5 Configuring the Drives on the New Drive Plate

Determine where you will install the drives on the drive plate as follows:

If	Then
You are reinstalling one RZ22/RZ23 drive with the RX23 diskette drive	the RZ22/RZ23 should be in position 3 with the RX23 in position 2.
You are reinstalling two RZ22/RZ23 drives with the RX23 diskette drive	the RZ22/RZ23s should be in position 3 and 4 with the RX23 in position 2.

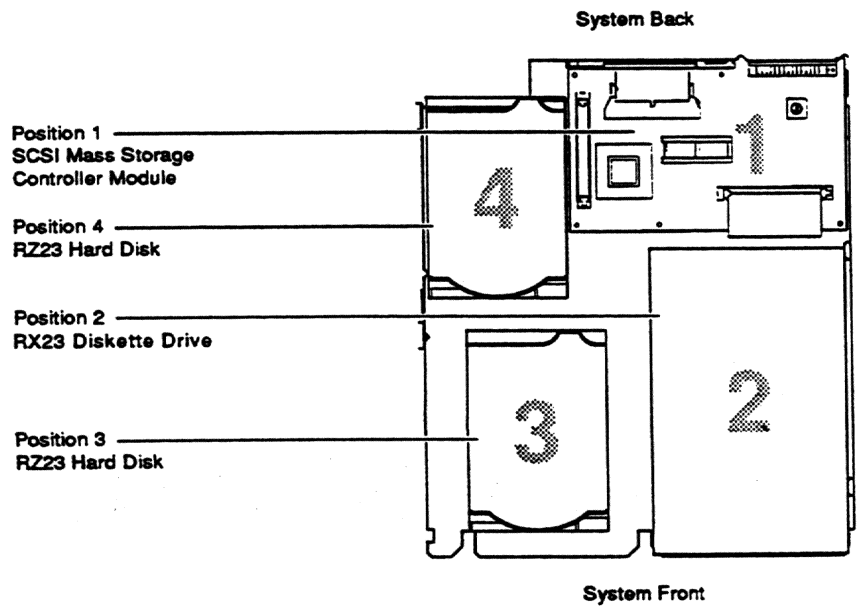

MLC-002894
MA-X0859-89A

3.6 Installing the RZ22/RZ23 Disk Drive(s)

To install the RZ22/RZ23 disk drive(s):

Mount the Drives

1. Install four screw/grommets (PN 12-31734-01) on the bottom of the RZ22/RZ23 drive.
2. Insert the drive (with the power connector towards the front) on the four keyhole slide mount openings in its proper position on the drive plate.

NOTE

If you are mounting a drive in position 4, you need to remove the MSC module for access to the drive's mounting holes.

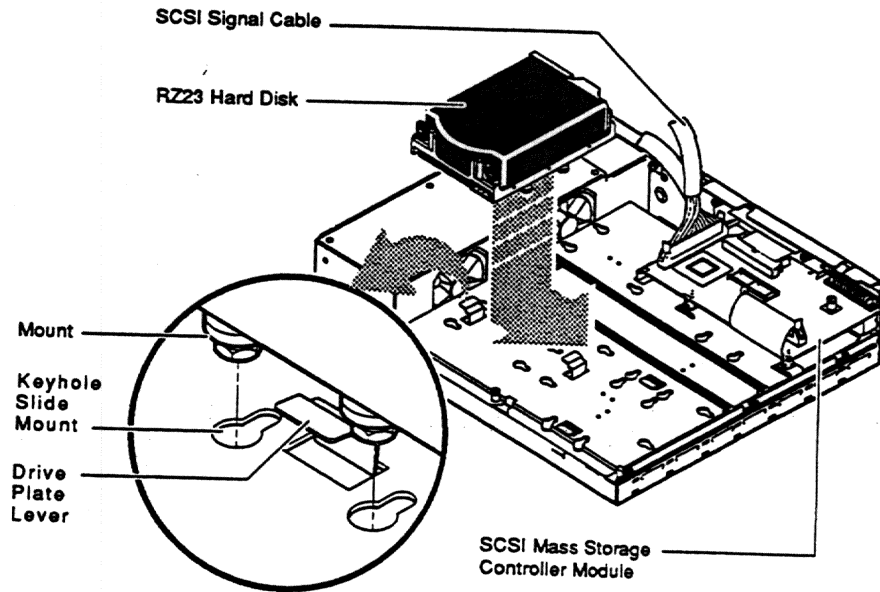

MLO-002896
MA-X0860-89

3. Press the RZ23 hard disk down and slide it in the keyhole slide mount openings to lock it on the drive plate. The drive plate lever should pop up to lock the drive in place.
4. Repeat steps 1 through 3 for each drive that needs to be installed.

Cable the Drives

The following figure shows the five connectors of the new power cable from the kit. The connectors are numbered for reference.

1. Connect the male connector ② to the power supply.

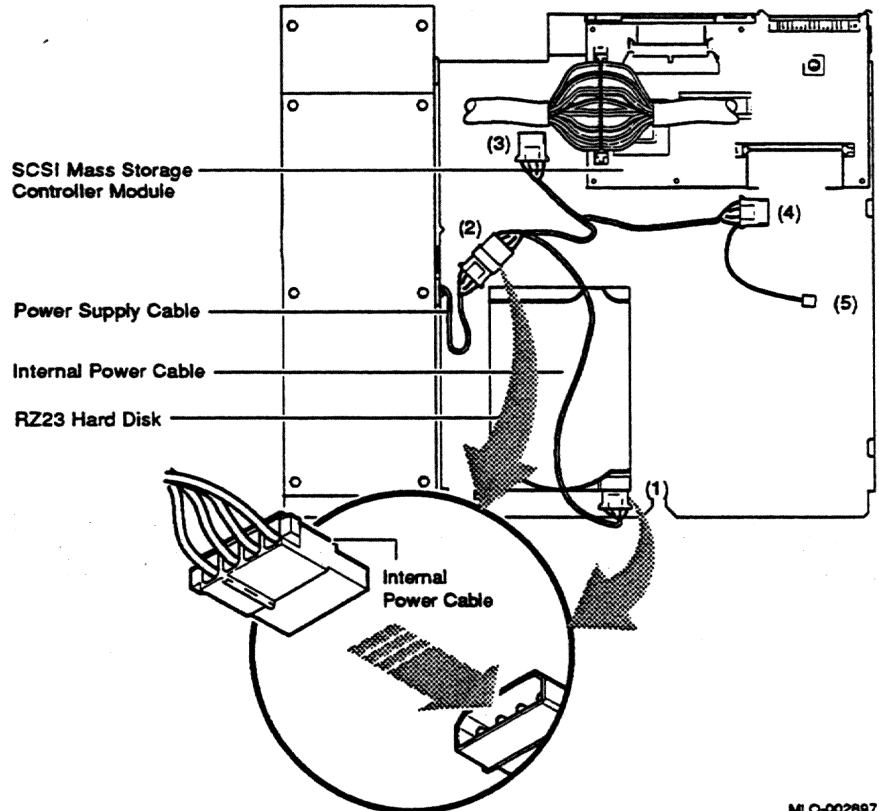

MLC-002867
MA-X0861-89

2. Connect the other ends of the power cable to the RZ23 hard disk drives ① or ③, depending on the position of the drives.

64 Upgrading a Model 30 (With Diskette)

3. If the larger (100 pin) end of the SCSI signal cable is not already connected to the SCSI port A on the MSC module, then connect it now.

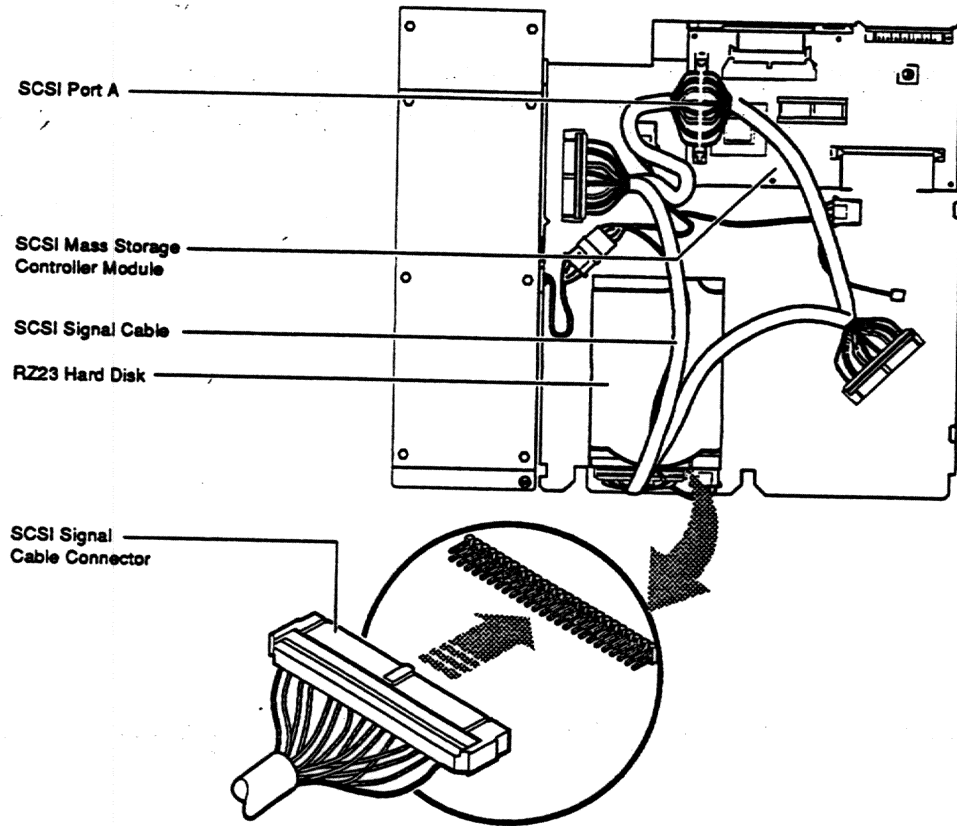

MLC-002888
MA-X0882-89

4. Connect the SCSI signal cable (PN 17-02439-01) to the RZ23 hard disk drives.

3.7 Installing the RX23 Diskette Drive

To install the RX23 diskette drive:

Assemble the RX23 SCSI adapter assembly

1. Remove the old adapter bracket from the RX23 diskette drive.
2. Install the eject button on the RX23 drive.

NOTE

Before performing the next step, check the serial number on the RX23 drive. If it is SH91300639 or lower, the component leads under the drive may need to be trimmed before installing the front bezel on the drive. Trim the leads so that the bezel does not make contact with these leads.

3. Snap on the front bezel.
4. Mount the RX23 on the new SCSI adapter mounting bracket using four of the metric screws (PN 90-10981-01). See the following figure for reference.
5. Turn the SCSI adapter mounting bracket over and install the SCSI adapter module (component side down) using five of the screws (PN 90-09708-00).
6. Turn the SCSI adapter mounting bracket over again and connect the 34-pin cable (PN 17-02221-02) to the RX23 drive and to the SCSI adapter module.

NOTE

Once the RX23 drive and the SCSI adapter module is mounted on the mounting bracket, it becomes one FRU and cannot be ordered individually.

Set the SCSI ID Switches

1. Locate the SCSI ID switches (1, 2, and 3) on the RX23 SCSI adapter assembly.

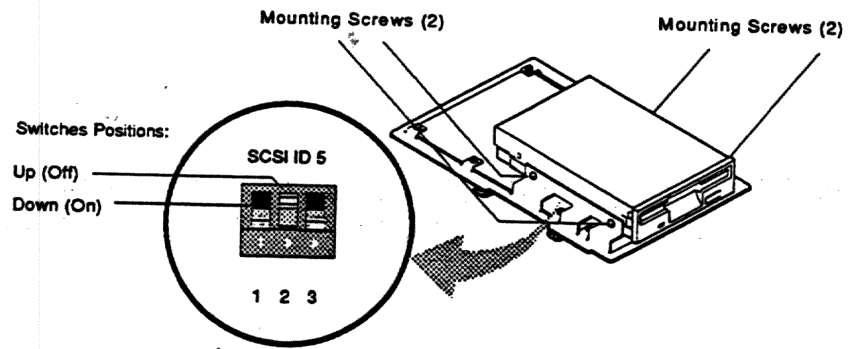

MLC-002886
MA-X0851-88

2. Use a pen or small pointed object to move the switches up or down as necessary to set the switches to the following positions:

Switch 1 = down (on)
 Switch 2 = up (off)
 Switch 3 = down (on)

Table 3-1 lists all possible settings for the RX23 diskette drive.

Table 3-1 RX23 SCSI ID Switch Settings

SCSI ID	1	2	3
0	Off	Off	Off
1	On	Off	Off
2	Off	On	Off
3	On	On	Off
4	Off	Off	On
5 ¹	On	Off	On
6 ²	Off	On	On
7 ³	On	On	On

¹Recommended ID for the RX23 diskette drive.

²Reserved ID for SCSI controller.

³Reserved for future use—do not use.

Mount the RX23 SCSI Adapter Assembly

1. Install four screw/grommets on the bottom of the drive.
2. Tuck the SCSI B port terminator cable under the MSC module. This cable terminates the SCSI B port and does not connect to any internal drives.
3. Insert the assembly on the four keyhole slide mount openings on the drive plate.

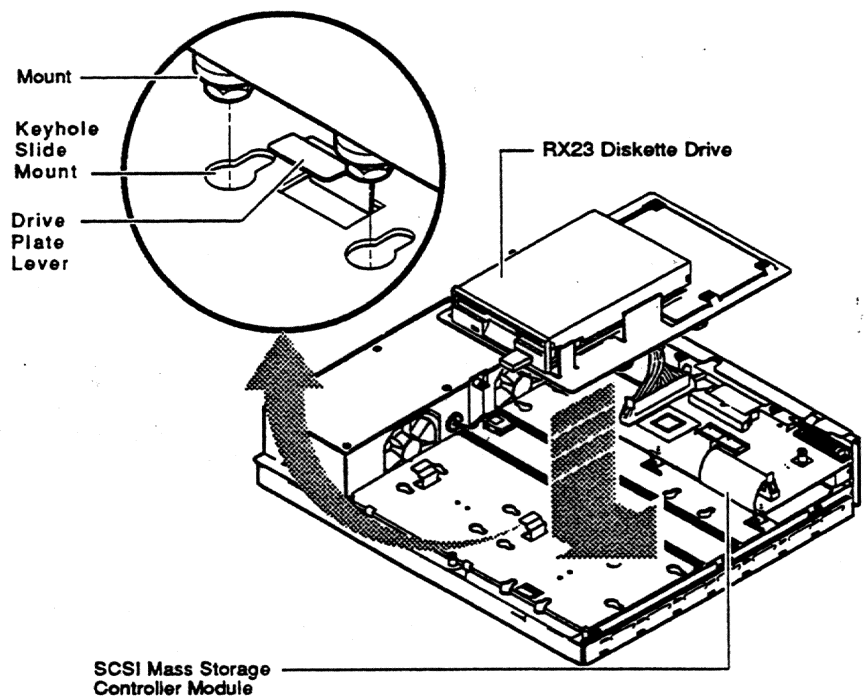

MLC-002857
MA-X0852-89

4. Press the RX23 SCSI adapter assembly down and slide it in the slide mount openings to lock it on the drive plate. The drive plate lever should pop up to lock the assembly in place.

Cable the RX23 SCSI Adapter Assembly

The following figure shows the cable connectors numbered for reference.

1. If you have not already connected the male connector to the power supply in the previous sections, then connect it now.
2. Connect the number ⑤ connector on the power cable to the RX23 diskette drive.

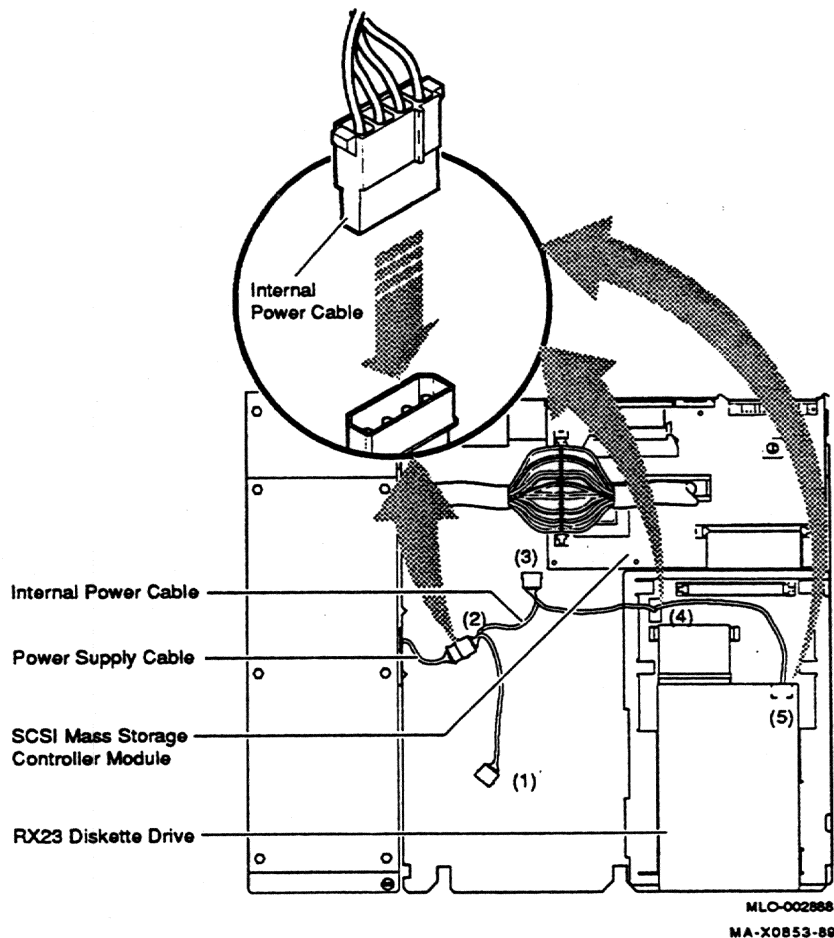

3. Connect the number ④ connector on the power cable to the RX23 SCSI adapter module.

4. Connect the SCSI signal cable (PN 17-02439-01) to the RX23 SCSI adapter module.

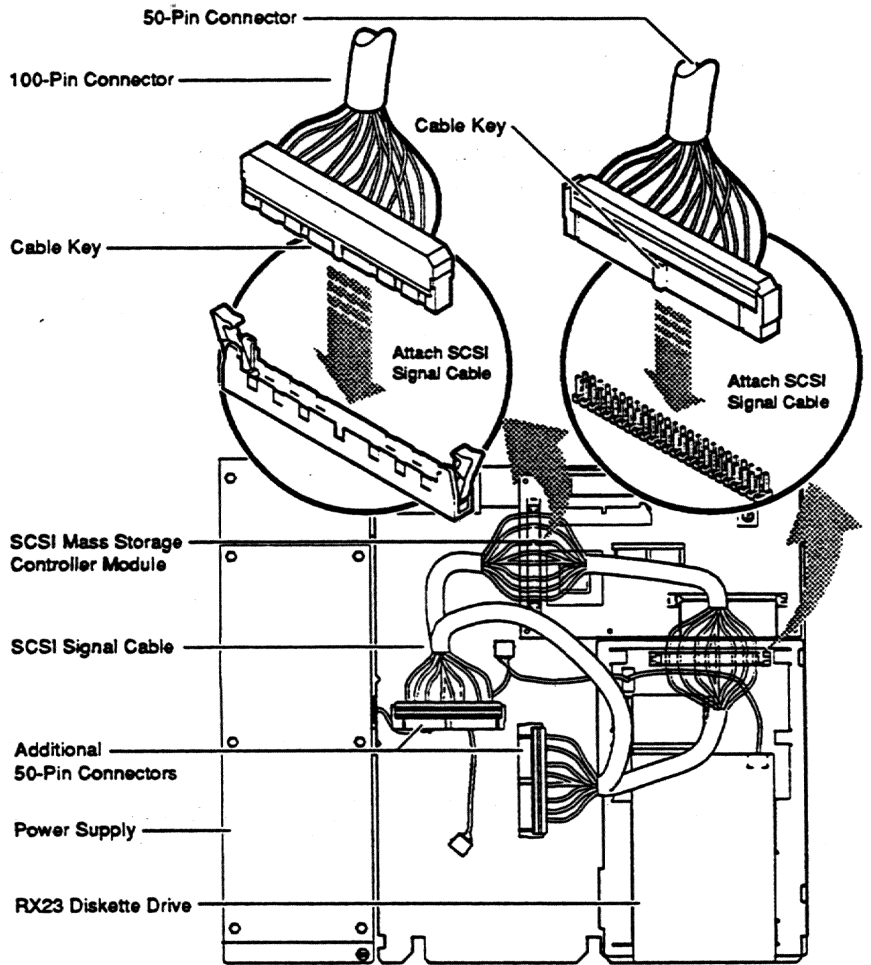

MLO-002869

MA-X0854-89

5. If the SCSI signal cable is not already connected to the SCSI port A on the MSC module, then connect it now.

3.8 Replacing the Power Supply Screws

To replace the power supply screws:

1. Remove the two phillips-head screws from the side of the power supply.
2. Install two of the three torx-head power supply safety screws (PN 12-30934-01) from the kit into the side of the power supply using the torx-head screwdriver.

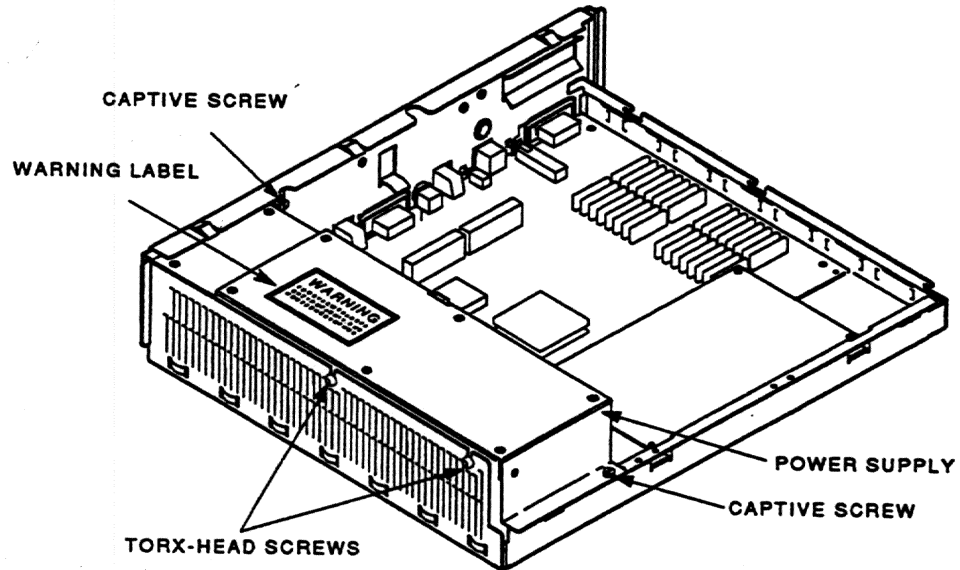

MA-X0808-88A

3. Install the power supply warning label on the power supply.

3.9 Installing the New Bezel Window

To install the new bezel window:

1. On the cover of the system box, remove the six screws and remove the front bezel from the cover.

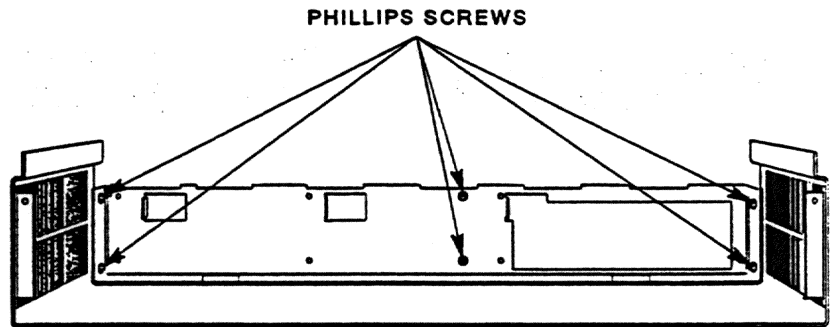

MA-X0517-89

2. Separate the old RX23 bezel insert from the front bezel.

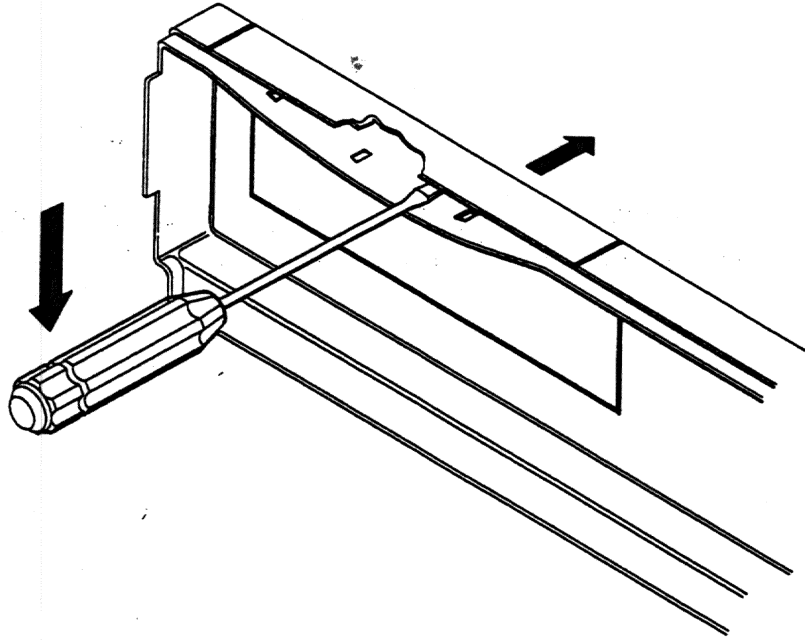

MA-X0516-89

3. Install the new bezel window from the kit on the front bezel by reversing the previous steps 1 and 2.
4. Remove the VAXstation 3100 medallion from the system box cover.
5. Install the new VAXstation 3100 M 38 medallion from the kit in the cover.
6. Reinstall the front bezel on the cover and reinstall the six screws.

3.10 Installing the Upgrade Label

Install the upgrade label from the kit on the back of the system box. Be sure not to cover over any existing labels.

3.11 Reinstalling the System Box Cover

To reinstall the system box cover:

1. Install the system box cover and tighten the two cover screws.
2. Refer to Chapter 1 of the maintenance guide. Run a self-test and the system exerciser to verify the status of the new system module.

3.12 Completing the Installation

The VAXstation 3100 replaced components as well as the excess materials (if any) from the upgrade kit are the property of Digital. You and the customer will need to fill out the upgrade forms in Appendix A and return them to the appropriate locations, as described in Appendix A.

4

Upgrading the Model 40

This chapter contains installation procedures for upgrading a VAXstation 3100 model 40 system to a VAXstation 3100 model 48 system.

4.1 PV15U-AA Kit Contents

The following table lists the contents and part numbers of the PV15U-AA kit:

Kit Item	Part Number
KA42-BA system module	54-19356-01
SCSI/SCSI controller	54-17445-05
Owners manual	EK-VSM40-DK
VAXstation 3100 Upgrade Installation Guide	EK-345AA-IN
Medallion, VAXstation 3100 M 48	
Upgrade label	36-15946-01

4.2 Preparing the System for Installation

To prepare the system for installation:

Shut Down the System

1. Shut down the system software.
2. Run a self-test to verify the operation of the present configuration.

>>> TEST F 1

3. Turn the system power switch off.

Open the System Box

CAUTION

Wear a static wrist strap and use a static mat (PN 29-26242-00) when replacing FRUs.

1. Unscrew the two cover screws.

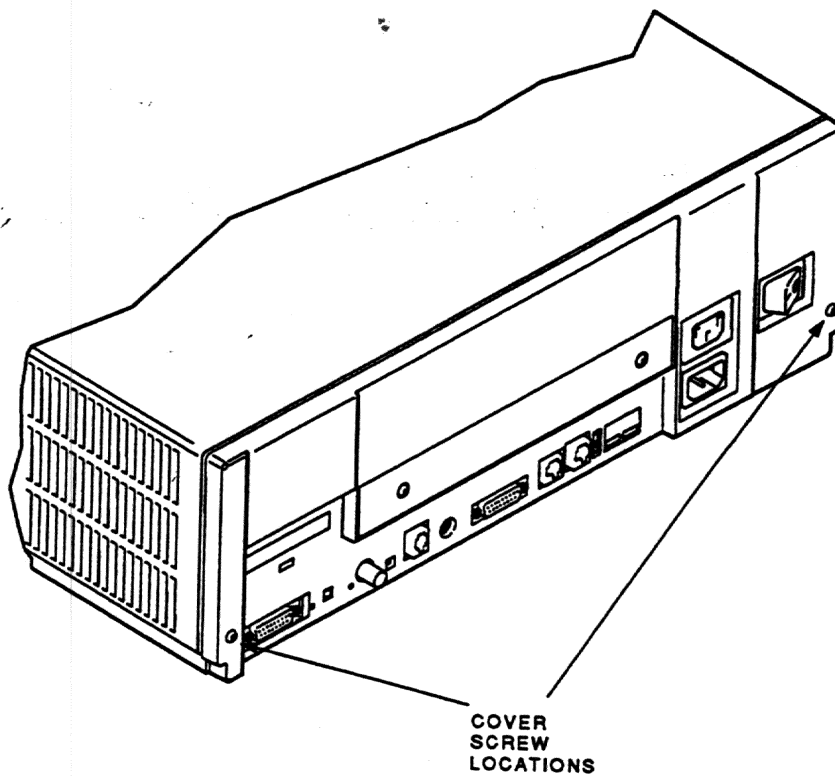

MA-X0813-88

2. Slide the cover forward and up off the system box.

Remove the Upper Drive Plate

CAUTION

You must note which cables connect to which drive when disconnecting them from the system. Write the type of drive and its position on a piece of tape and wrap the tape around the connector before disconnecting it. This will help you when reinstalling the drives.

- 1. Disconnect the power cables and the SCSI bus cables from the drives on the upper drive plate.

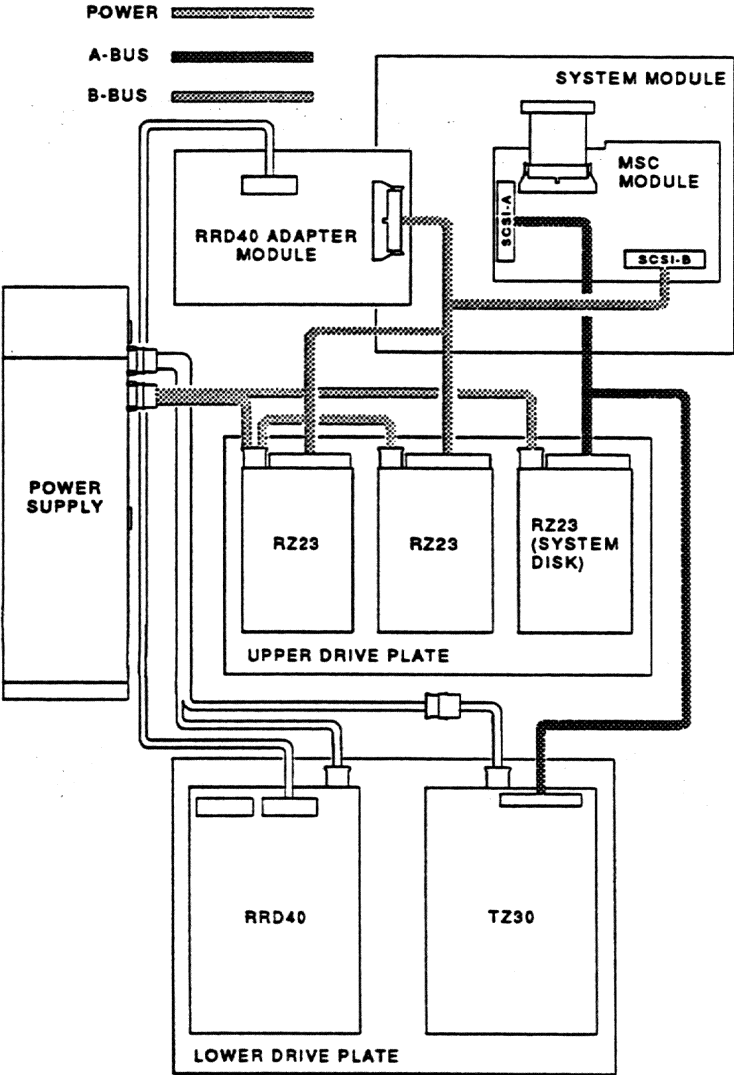

78 Upgrading the Model 40

2. Remove the RRD40 adapter module from the four standoffs (if installed).
3. Unscrew the five screws on the upper drive mounting panel and lift the top panel from the lower panel.

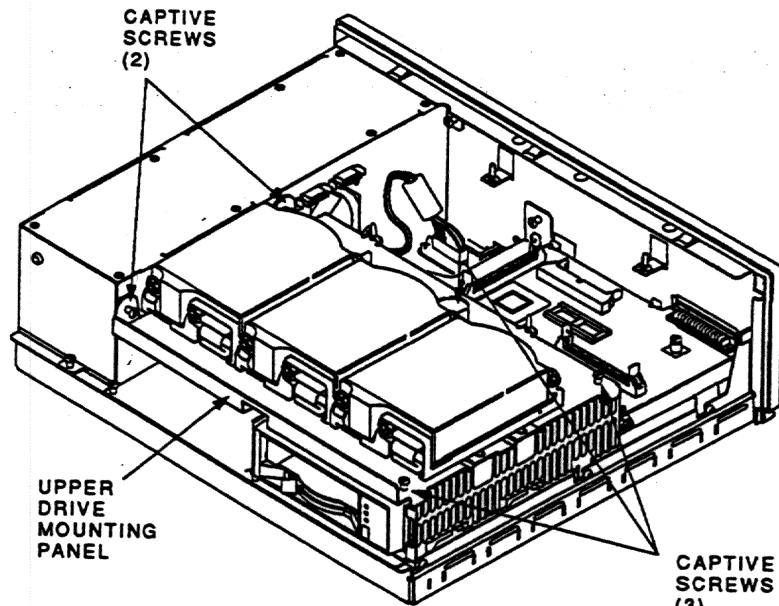

MA-X0536-89

Remove the Lower Drive Plate

1. Disconnect the power cable from the TZ30 tape drive (if installed) and disconnect the mass storage controller (MSC) cable.

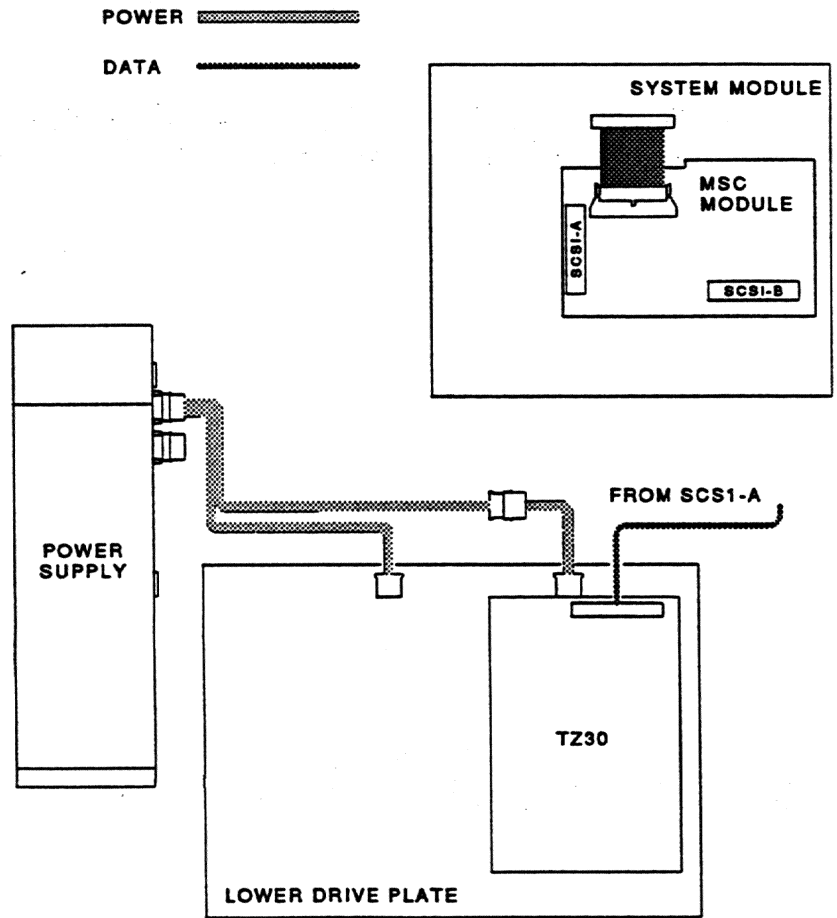

2. Unscrew the seven screws.

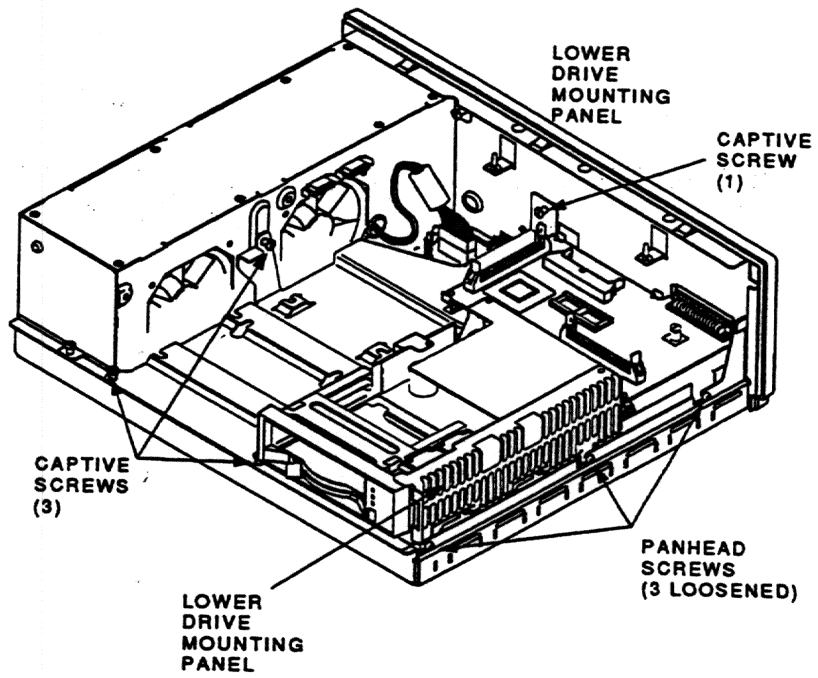

MA-X0538-89

3. Slide the plate forward, then lift the plate from the system box.

Remove the Memory Module

Remove the memory module from the four standoffs, then lift the memory module off the system module. Two connectors will disconnect as you lift the module.

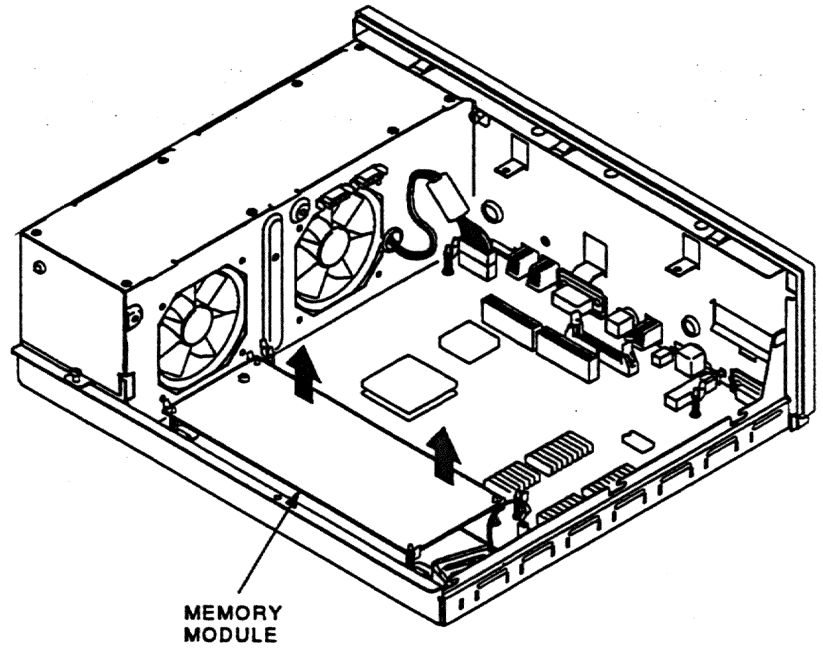

MA-X0848-88

Remove the Graphic Module (If present)

Remove the graphic module from the four standoffs, then lift the graphic module off the system module. Two connectors will disconnect as you lift the module.

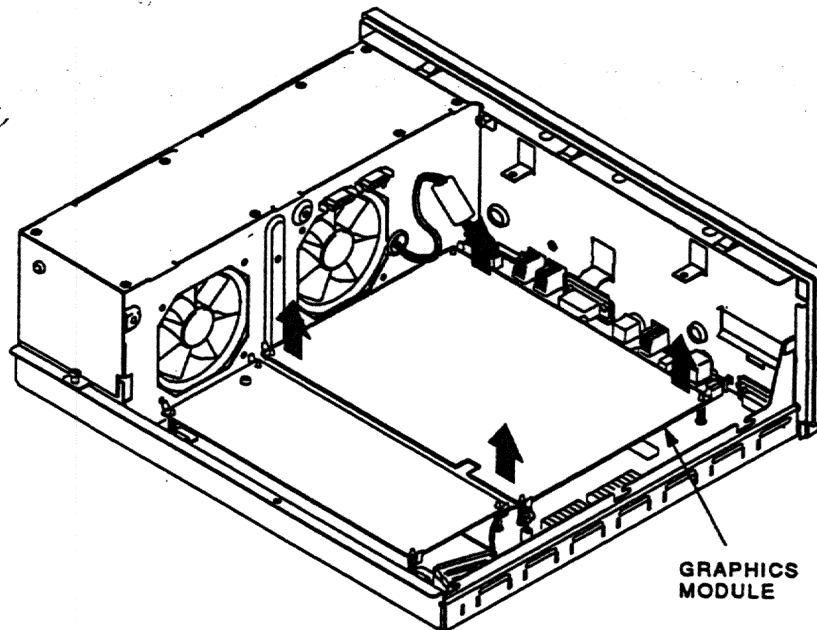

MA-X0847-88

Remove the System Module

1. Disconnect all cables from the back of the system box.
2. Disconnect the MSC cable from the system module.

NOTE

Before disconnecting the power cable in the next step, be sure to release the connector latch on the back side of the power connector.

3. Disconnect the power cable and the battery cable from the system module.

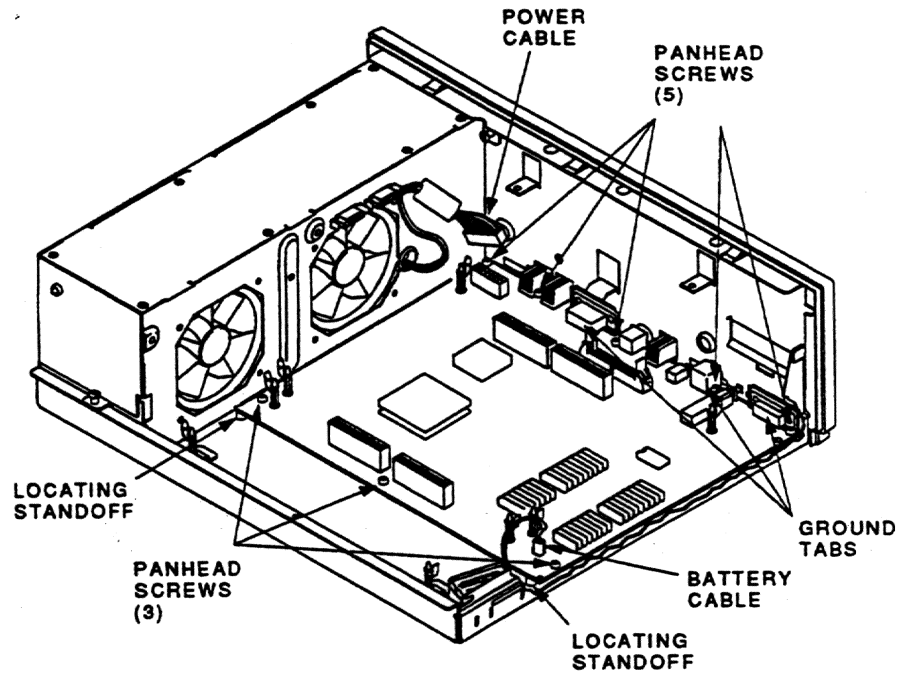

MA-X0849-88A

4. Remove the system module by carefully popping off the two front corners of the two locating standoffs.

CAUTION

In the next step, be careful not to bend the pins on the Ethernet ID ROM.

5. Remove the Ethernet ID ROM from the system module you removed. Check the position of pin 1 (notched) on the ROM. Install the ID ROM on the new system module in the kit.

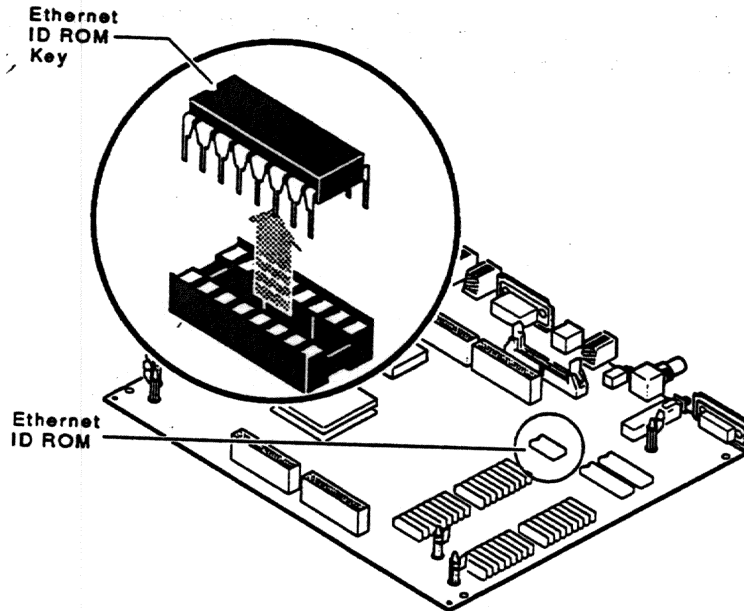

MLD-002918
MA-X0872-89

4.3 Installing the Modules

To install the modules:

Install the New System Module

NOTE

When reinstalling the system module, install the connector end first through the openings in the rear of the box. Push the module back to load the connector ground tabs. Snap the module on both locating standoffs. All screw holes will then be aligned.

1. Check the position of the S3 switch next to the LEDs on the back of the system module. Be sure S3 is in the down position (the down position enables the monitor to be the console and the up position enables a terminal connected to the printer port to be the console).
2. Install the connector end of the system module first through the openings in the rear of the box. Push the module back to load the connector ground tabs, then snap the module on both locating standoffs. All screw holes will then be aligned.
3. Install the eight screws on the system module.

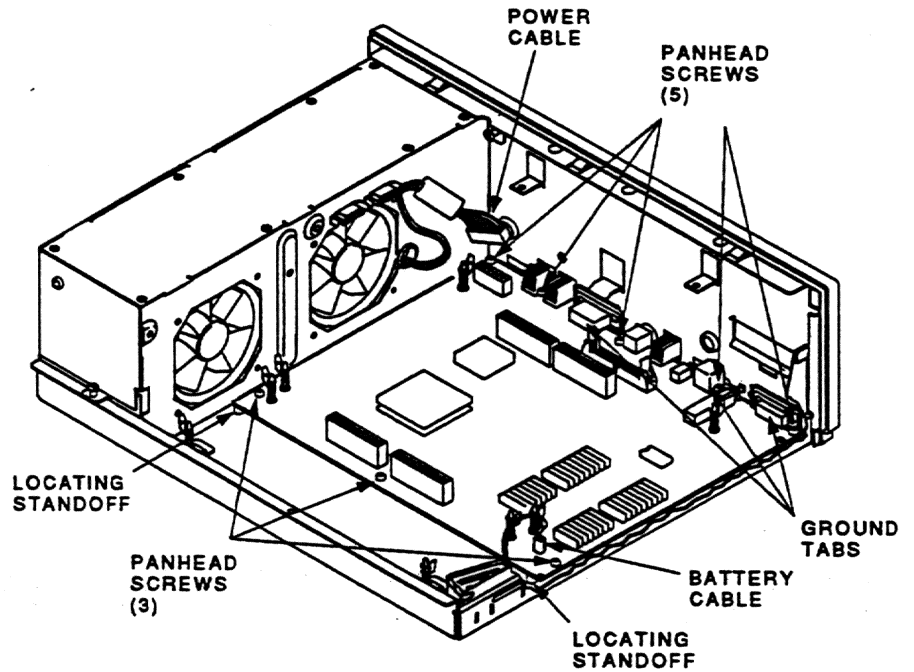

MA-X0849-88A

4. Connect the power cable and the battery cable to the system module.
5. Reconnect all cables to the back of the system box.

Reinstall the Memory Module

Install the memory module(s) on the new system module as shown in the following two figures. The first figure is for 4 or 12 Mbyte (single) memory module installation; the second figure is for 8 or 16 Mbyte (dual) memory module installation. After the module(s) are installed, press down on top of the module's connectors to firmly seat the connectors.

4 or 12 Mbyte Memory Module Installation

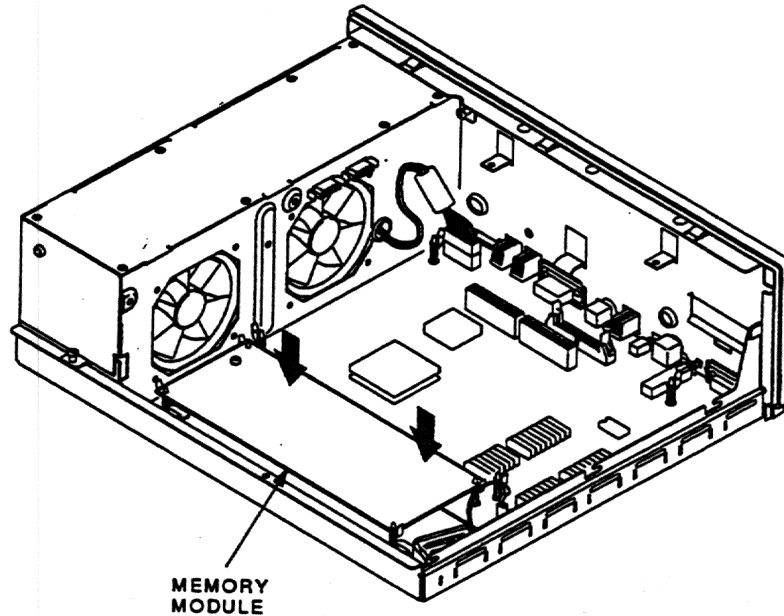

MA-X0848-88A

8 or 16 Mbyte Memory Module Installation

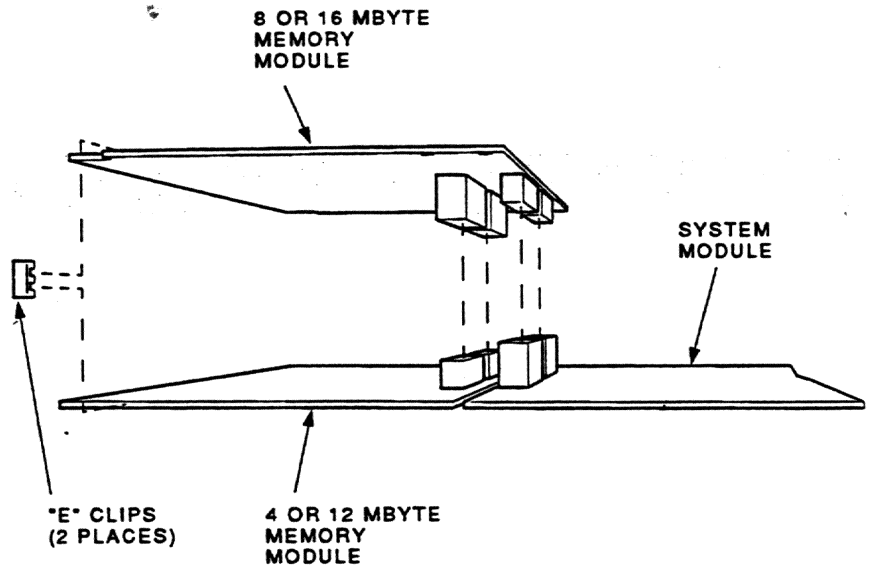

MA-X1174-88A

Reinstall the Graphics Module (If present)

Reinstall the graphics module on the new system module. After the module is installed, press down on top of the module's connectors to firmly seat the connectors.

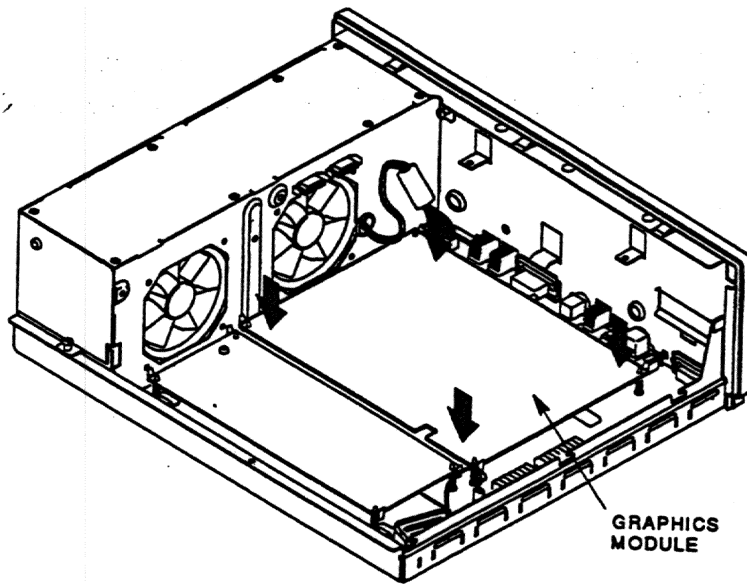

MA-X0847-88A

Reinstall the Lower Drive Plate

1. Connect the MSC cable to the new system module.
2. Position the lower drive mounting plate and tighten the seven screws.

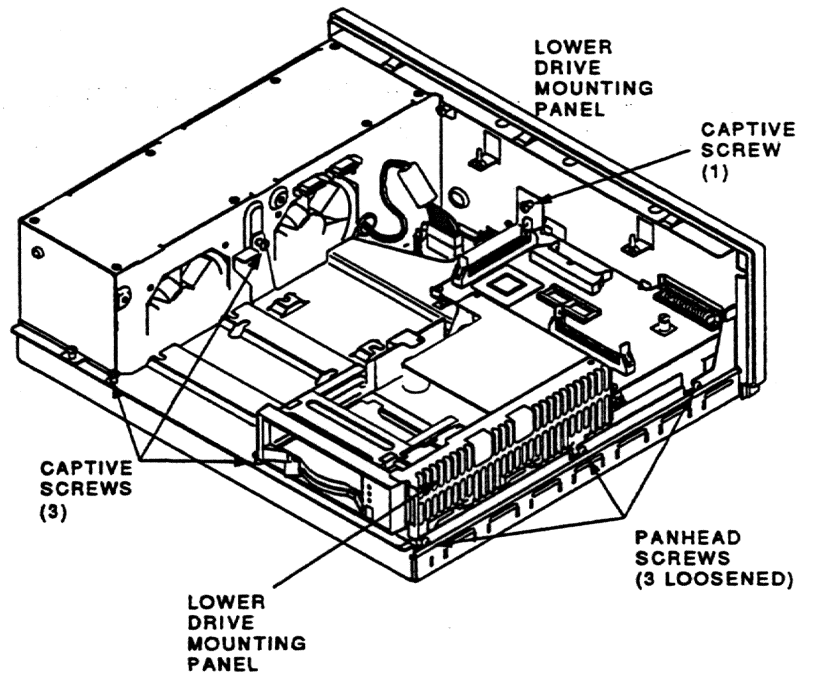

MA-X0538-89

3. Connect the data cable from the RRD40 adapter module to the RRD40 compact disk drive.

4. Connect the SCSI bus cables and the power cables to the TZ30 (if installed) and connect the power cable to the RRD40 compact disk drive.

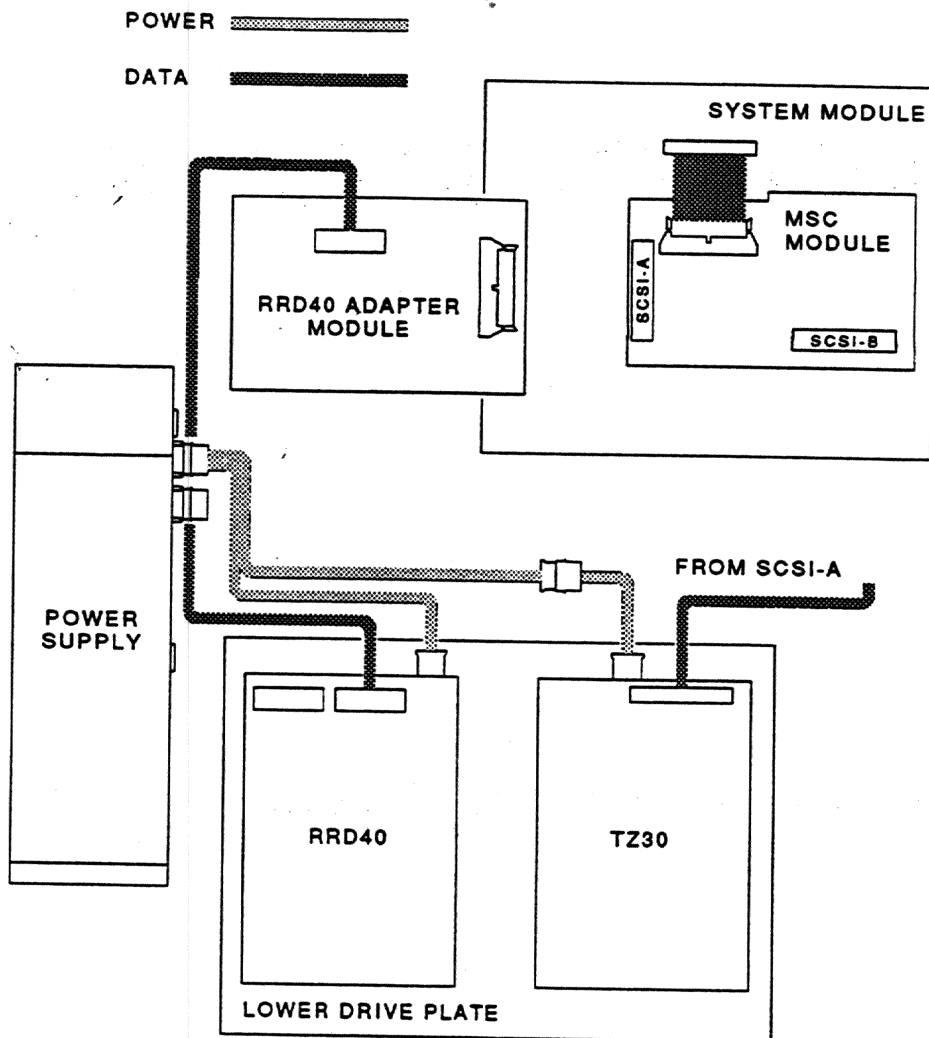

MA-X0815-88

5. Connect the MSC cable to the MSC module.

Reinstall the Upper Drive Plate

1. Position the upper mounting drive plate on the system box and tighten the five screws.

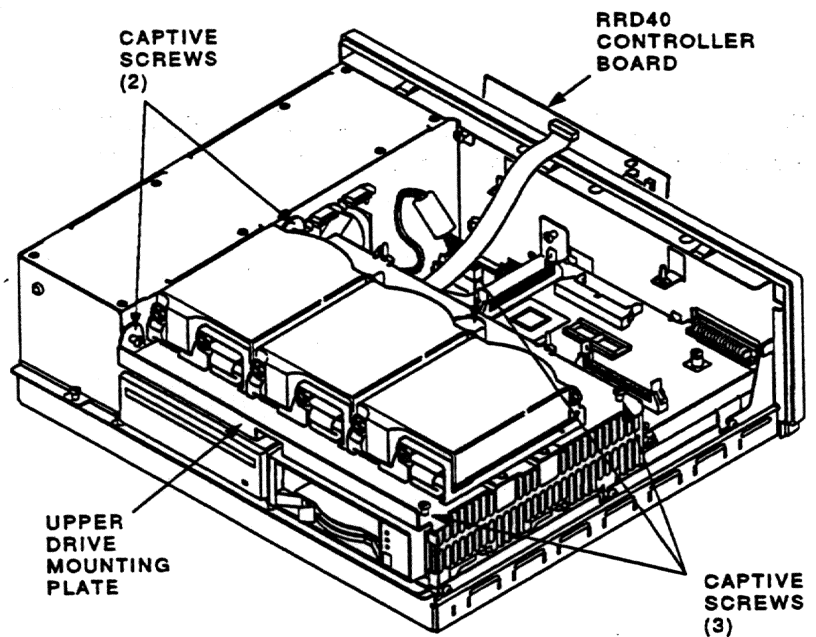

MA-X0859-88

2. Mount the RRD40 adapter module on the four standoffs.

Reconnect the Upper Drive Plate Cables

Connect the SCSI bus cables and the power cables to any and all RZ23s and connect the SCSI bus to the RRD40 adapter module.

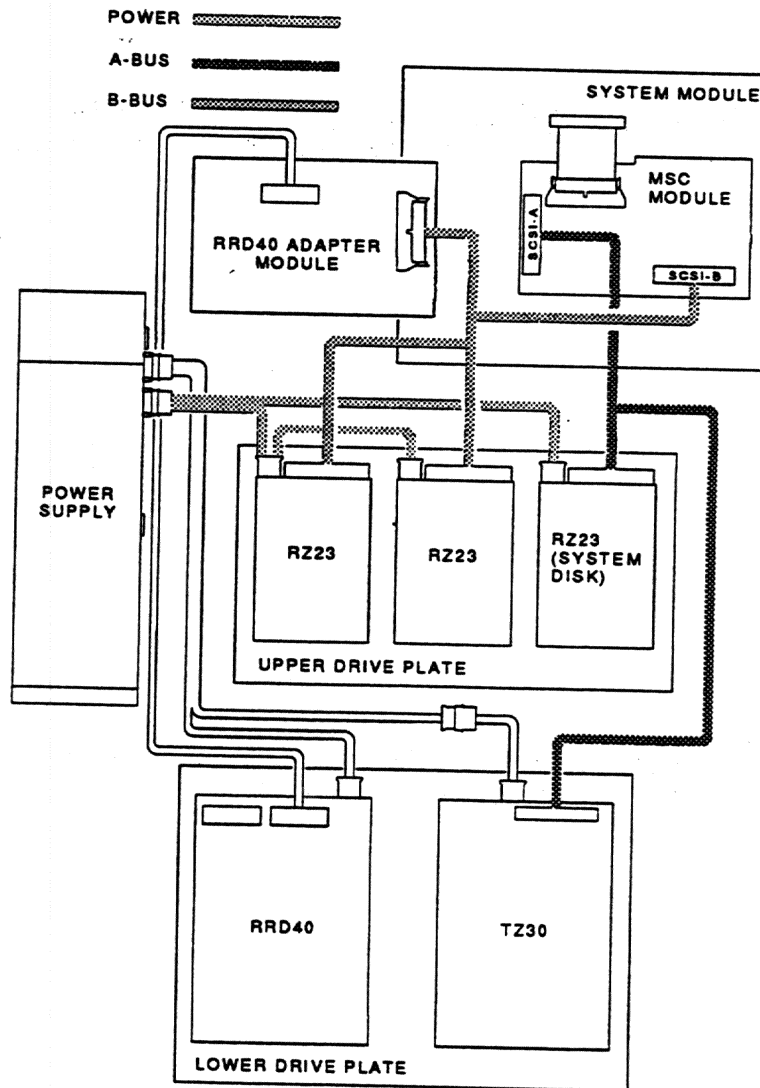

4.4 Replacing the MSC Module

To replace the MSC module:

Remove the MSC Module

1. Remove the RRD40 adapter module from the four standoffs.
2. Disconnect the SCSI cables from both SCSI port A and B.
3. Disconnect the MSC cable from the MSC module.
4. Unscrew the captive screw on the MSC module.
5. Remove the MSC module from the drive plate.

Install the New MSC Module

1. Snap the MSC module in place on the drive plate.
2. Tighten the captive screw on the MSC module.
3. Reconnect the SCSI port A and B cables to the MSC module.
4. Mount the RRD40 adapter module on the four standoffs.

4.5 Changing the Medallion

To change the medallion:

1. Remove the VAXstation 3100 medallion from the system box cover.
2. Install the new VAXstation 3100 M 48 medallion from the kit in the cover.

4.6 Installing the Upgrade Label

Install the upgrade label from the kit on the back of the system box. Be sure not to cover over any existing labels.

4.7 Reinstalling the System Box Cover

To reinstall the system box cover:

1. Install the system box cover and tighten the two cover screws.
2. Refer to Chapter 1 of the maintenance guide. Run a self-test and the system exerciser on the new drive to verify its status.

4.8 Completing the Installation

The VAXstation 3100 replaced components as well as the excess materials (if any) from the upgrade kit are the property of Digital. You and the customer will need to fill out the upgrade forms in Appendix A and return them to the appropriate locations, as described in Appendix A.

A

Upgrade and Return Forms

The Customer Service Engineer who performs the upgrade must complete two of the three types of forms in this Appendix. The third form must be completed by both the customer and the Customer Service Engineer as described below.

- The Customer Service Engineer must return the Customer Service Upgrade Worksheet to the local contracts administrator.
- The Customer Service Engineer must return one copy of the Customer Service Installation Receipt to the local CAS group and give one copy to the customer.
- The Customer Service Engineer must work together with the customer to insure that the hardware is packaged properly for the return and that the proper return forms in this appendix are filled out.
 - a. Have the customer return one copy of the Returns Material Checklist with all modules and hardware that must be returned.
 - b. Have the customer contact CAS to verify the RA number and to notify CAS that equipment is ready to be returned.

CAS will then contact US Area Distribution to arrange for pick-up by a courier service. The return status will be monitored by Sales and CAS on a regular basis. Sales/DOM will authorize enforcement of additional charge in the event of a non-return (usually if equipment is not returned within 60 days).

Labor Activity Reporting

Use the labor code UPG31 for all labor activity reporting on all four of the upgrade kits.

