

VAXstation II

Owner's Manual,
BA123 Enclosure

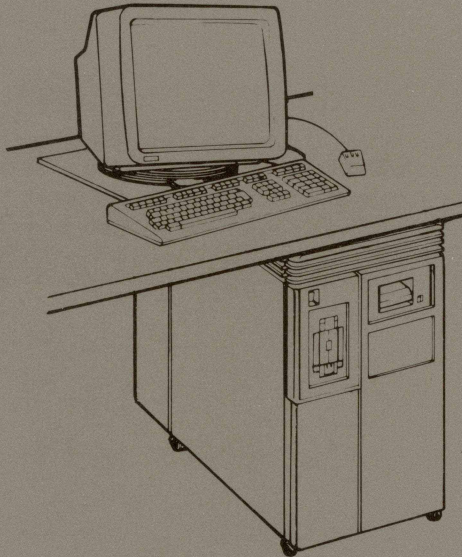

VAXstation II

Owner's Manual,
BA123 Enclosure

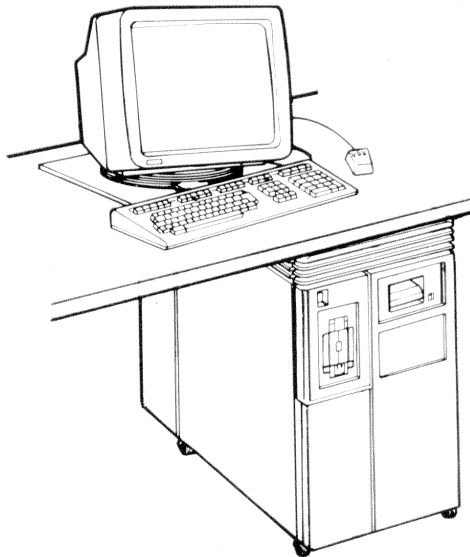

Prepared by SSG/ML Publications
of Digital Equipment Corporation

The information in this document is subject to change without notice and should not be construed as a commitment by Digital Equipment Corporation. Digital Equipment Corporation assumes no responsibility for any errors that may appear in this document.

The software described in this document is furnished under a license and may be used or copied only in accordance with the terms of such license.

No responsibility is assumed for the use or reliability of software on equipment that is not supplied by Digital Equipment Corporation or its affiliated companies.

© Digital Equipment Corporation 1985.
All Rights Reserved.

Printed in U.S.A.

A postage-paid READER'S COMMENTS form is included on the last page of this document. Your comments will assist us in preparing future documentation.

The following are trademarks of Digital Equipment Corporation:

DEC	digital ™	MicroVMS	RT
DECmate		PDD	UNIBUS
DECUS		P/OS	VAX
DECwriter		Professional	VAXstation
DIBOL		Rainbow	VMS
MassBus		RSTS	Work Processor
MicroVAX		RSX	

Contents

Preface

What the VAXstation II Is.....	vii
Manual Conventions.....	viii
Manual Organization	viii
Part I: Base System Installation.....	viii
Part II: Operation	ix
Part III: Option Installation	ix
Part IV: Troubleshooting	ix
Part V: Appendix.....	ix
Part VI: Glossary.....	ix
Related Documents.....	ix

Part I: Base System Installation

Preparing for Installation

CHECK YOUR SHIPMENT.....	1-1
SITE-PREPARATION REVIEW	1-3
Space Planning.....	1-3
The System Unit	1-3
The Monitor	1-4
Electrical Requirements	1-5
Environment.....	1-6
Temperature and Humidity.....	1-6
Static Electricity.....	1-6
Clean Area	1-6
Supplies Storage	1-6
Accommodations for an Ethernet Connection	1-6

Setting Up the Hardware

SETTING UP THE SYSTEM UNIT	2-1
SETTING UP THE MONITOR	2-1
SETTING UP THE KEYBOARD AND POINTING DEVICE	2-10
CONNECTING THE VAXSTATION II	2-14
TESTING THE VAXSTATION II	2-25
Checking the Monitor	2-25
Checking the System	2-28
WHERE TO GO FROM HERE	2-42

Part II: Operation

VAXstation II Hardware

VAXSTATION II CONTROLS AND INDICATORS	3-1
The System Power Switch and Indicators	3-3
The Restart/Run Pushbutton	3-3
The DC OK Indicator	3-4
The Halt Pushbutton	3-4
The Fixed Disk Pushbuttons	3-5
TURNING ON THE SYSTEM	3-5
Initial Control Panel Switch Settings	3-6
TURNING OFF THE SYSTEM	3-7
VR260 MONITOR CONTROLS AND INDICATORS	3-8
THE RD52 OR RD53 FIXED DISK DRIVE	3-11
THE DEQNA COMMUNICATIONS MODULE	3-12
RX50 DUAL DISKETTE DRIVE	3-13
RX50 Diskettes	3-14
Handling and Storing Diskettes	3-15
Protecting Diskettes from Accidental Overwriting	3-15
Inserting a Diskette	3-16
TK50 TAPE DRIVE	3-17
Cartridge Release Handle	3-17
The Load/Unload Button	3-17
Labeling a TK50 Tape Cartridge	3-19
Handling and Storing Tape Cartridges	3-19
Protecting Tape Cartridges from Accidental Over-Writing	3-20
Inserting a TK50 Tape Cartridge	3-20

Rewinding and Unloading a Tape Cartridge.....	3-21
MAKING BACK-UP COPIES	3-23

Part III: Option Installation

Installing Options

THE PRINTERS	4-2
The LA50	4-3
The LA210	4-4
The LN03-AA	4-5
Printer Connection to the VAXstation II.....	4-7
THE TABLET	4-9
THE MEMORY MODULES	4-10
THE FREE-STANDING DISK SUBSYSTEM	4-11
THE DZQ11 ASYNCHRONOUS MULTIPLEXER.....	4-12
THE DMV11 SYNCHRONOUS LINE CONTROLLER	4-12

Part IV: Troubleshooting

Troubleshooting Procedure

BASIC TROUBLESHOOTING	5-1
POWER-UP MESSAGES	5-7
MAINTENANCE SYSTEM	5-8
The Maintenance System Main Menu	5-8
MONITOR TROUBLESHOOTING	5-11
Replacing the Fuse	5-11

Service

HOW TO CALL FOR DIGITAL SERVICE	6-1
AVAILABLE DIGITAL SERVICES	6-2
DECservice	6-2
Basic Service.....	6-2
Per Call Service	6-2
Carry-In Service	6-3
DECmailer Service.....	6-3
Spare Parts	6-3

Part V: Appendix

Part VI: Glossary

Figures

1-1	A Typical VAXstation II 630QW-A2/A3	1-1
1-2	Dimensions of the System Unit.....	1-4
2-1	Tilt-Swivel Base Parts	2-4
2-2	Installed Tilt-Swivel Base.....	2-5
2-3	VAXstation II System Unit Labels	2-14
2-4	VAXstation II Connection to a DELNI.....	2-13
2-5	Maintenance System Main Menu	2-26
3-1	Controls and Indicators.....	3-2
3-2	Power-Up Screen.....	3-7
3-3	Front and Side Controls.....	3-8
3-4	Rear Controls and Connectors.....	3-11
3-5	RX50 Diskette.....	3-14
3-6	TK50 Tape Drive	3-17
4-1	Printer Connection to the VAXstation II	4-8
5-1	System Circuit Breaker	5-3
5-2	Maintenance System Main Menu	5-9
5-3	An Example of a System Configuration and Devices Screen	5-10

Tables

3-1	Normal Power-On Indications	3-6
3-2	TK50 Tape Drive Controls and Indicators	3-18
5-1	Basic Troubleshooting Procedures	5-2
5-2	Monitor Troubleshooting Procedures	5-11

This manual describes how to install, operate, and troubleshoot the VAXstation II system. DIGITAL recommends that you read this manual before you install your system.

If you experience system problems, use this manual to isolate the error before seeking other help from service personnel. If you then require further assistance, call 1-800-DEC-8000, and a DIGITAL representative will help you.

What the VAXstation II Is

The VAXstation II is a single-user, stand-alone, 32-bit microcomputer workstation. A standard system includes 2 megabytes of memory, a 19-inch (diagonal) black-and-white display monitor on a tilt-swivel base, a video controller, a mouse, a keyboard, a fixed disk drive, either a diskette or tape drive, and an Ethernet communication link. Bundled software includes the MicroVMS Full Kit operating system, MicroVMS Workstation software with graphics programming, and the Graphics Kernel System (GKS).

The VAXstation II system unit can be placed beside or under a desk, and peripherals on top of the desk.

Hardware options include printers, a tablet, memory modules, a free-standing disk drive, a tape drive subsystem, an asynchronous multiplexer line controller, and a synchronous line controller. Software options are DECnet, FORTRAN, C, and other products layered on the MicroVMS operating system.

The VAXstation II expands the utility and convenience of the MicroVMS operating system by providing the user with unlimited terminals (simulated

in "windows" on the VAXstation screen). Each simulated terminal runs processes independently of processes running in other terminals, and the terminal permits VAXstation keyboard association at any time. You can create, move, and discard simulated VT100 and/or Tektronix* 4014 terminals and other menus and processes in windows on the screen, using the mouse to move a pointer. The result allows you to view or manage a variety of activities at once. For example, you can do the following:

- Examine a compilation listing while editing the source file
- Read notices without exiting from a program
- Start one task and follow its progress while interacting with another task
- Send mail without exiting an editing session
- Print a list of files on your printer while creating other files (requires the printer option)

The VAXstation monitor and graphics module allow medium-resolution bit-map graphics applications. Using the MicroVMS graphics programming interface or GKS, a programmer can create applications that produce 2-dimensional pictures.

Manual Conventions

VAXstation II system controls and indicators are highlighted in bold lettering. The names of diagnostic tests are highlighted in bold as well. Titles of diagnostic media appear in italics.

Manual Organization

The manual is divided into five parts:

Part I: Base System Installation

This part describes how to unpack, install, and test the system. Read the following information before installing the system:

- **Chapter 1** describes preinstallation procedures, including checking the shipment components and ensuring adequate site preparation.
- **Chapter 2** describes how to set up the system unit, monitor, keyboard, and mouse and how to connect and test the system.

* Tektronix is a registered trademark of Tektronic Inc.

Part II: Operation

This part describes the operation of the VAXstation II:

- **Chapter 3** describes the system controls and indicators.

Part III: Option Installation

This part describes the options for the VAXstation II and gives installation information where applicable.

- **Chapter 4** describes the hardware options for the VAXstation II. They include the LA50, LA210, and LN03-AA printers, a tablet, memory modules, a free-standing disk drive, an asynchronous multiplexer and a synchronous line controller. The chapter gives installation information for the printers and the tablet.

Part IV: Troubleshooting

This part describes how to isolate a problem and decide what to do next. The following information is provided:

- **Chapter 5** outlines basic troubleshooting procedures, explains power-up messages, and describes the maintenance system for the VAXstation II. The chapter contains a section on troubleshooting procedures for the monitor.
- **Chapter 6** describes the services DIGITAL provides.

Part V: Appendix

The Appendix provides VAXstation II system specifications.

Part VI: Glossary

This part explains computer terms mentioned in the manual.

Related Documents

- *Read Me First* (Order No. AA-GS96A-TE) outlines the steps involved to install the hardware and MicroVMS software of a VAXstation system. The VAXstation manuals contain instructions needed to complete each step. The reverse side of the card suggests the order in which to read this documentation.

- *VAXstation II Technical Manual, BA123 Enclosure* (Order No. AZ-GMZAA-MN) contains detailed information about the VAXstation II hardware, in particular the VCB01 module. The manual is packaged in the same binder as this book.
- *VR260 Installation/Owner's Guide* (Order No. EK-VR260-IN-001) describes how to install the monitor, gives operating information, provides troubleshooting instructions, and lists specifications.
- *Tablet Installation Sheet* (Order No. EK-VSZZB-IN) explains how to set-up the device.
- *MicroVMS Release Notes* (Latest Version) contains last-minute information about MicroVMS.
- *MicroVMS User's Primer* (Order No. AA-Z210B-TE) introduces the MicroVMS operating system to novice users.
- *MicroVMS User's Manual* (Order No. AA-Z209B-TE) describes the operation of the MicroVMS operating system.
- *MicroVMS User's Pocket Reference* (Order No. AA-Z211B-TE) summarizes the DIGITAL Command Language (DCL), EDT editor, DIGITAL Standard Runoff (DSR), and MAIL commands.
- *MicroVMS FORTRAN Programmer's Primer* (Order No. AA-Z213A-TE) contains basic concepts of program development using FORTRAN in the MicroVMS environment.
- *MicroVMS FORTRAN Programmer's Manual* (Order No. AA-Z212A-TE) contains guidelines for using VAX FORTRAN with MicroVMS tools, such as run-time library routines, system services, the debugger, and relevant utilities. The manual presents a task-oriented approach to programming with FORTRAN on a MicroVMS system. Specifications for VAX FORTRAN statements are included in an appendix.
- *MicroVMS Programming Support Manual* (Order No. AA-DC87B-TE) contains the specifications for the following MicroVMS programming support tools: the run-time library routines, system services, terminal and mailbox I/O function codes, debugger, linker, file definition language, message utility, command definition utility, and condition codes.
- *MicroVMS Programming Pocket Reference* (Order No. AA-Z214A-TE) contains syntax specifications for the following programming tools: run-time library routines, system services, debugger commands, and relevant DCL commands. The pocket reference also includes a summary for dot notation.

- *MicroVMS Workstation User's Guide* (Order No. AV-EZ24C-TN) explains how to install the MicroVMS workstation software.
- *MicroVMS Workstation Graphics Programming Guide* (Order No. AA-G110A-TN) provides tutorial and reference information on the MicroVMS workstation graphics programming interface.
- *Installing VAX GKS/Ob* (Order No. AA-W156B-TE) describes the installation of GKS.
- *VAX GKS/Ob Software Reference Guide* (Order No. AA-BH53B-TE) contains reference information about GKS.
- *VAX GKS/Ob Pocket Guide* (Order No. AV-BH52B-TE) summarizes GKS functions and lists GKS FORTRAN binding functions and constant names.
- *MicroVMS Workstation Video Device Driver Manual* (Order No. AV-DY65C-TE) contains information about the VCB01 (QVSS) device driver for programmers.
- *KA630-A CPU Module User's Guide* (Order No. EK-KA630-UG) details the internal operation of the MicroVAX KA630-A CPU.
- *MicroVAX II Maintenance Information Kit* (Order No. ZNA3X-C3) is for users who want to service their own systems.

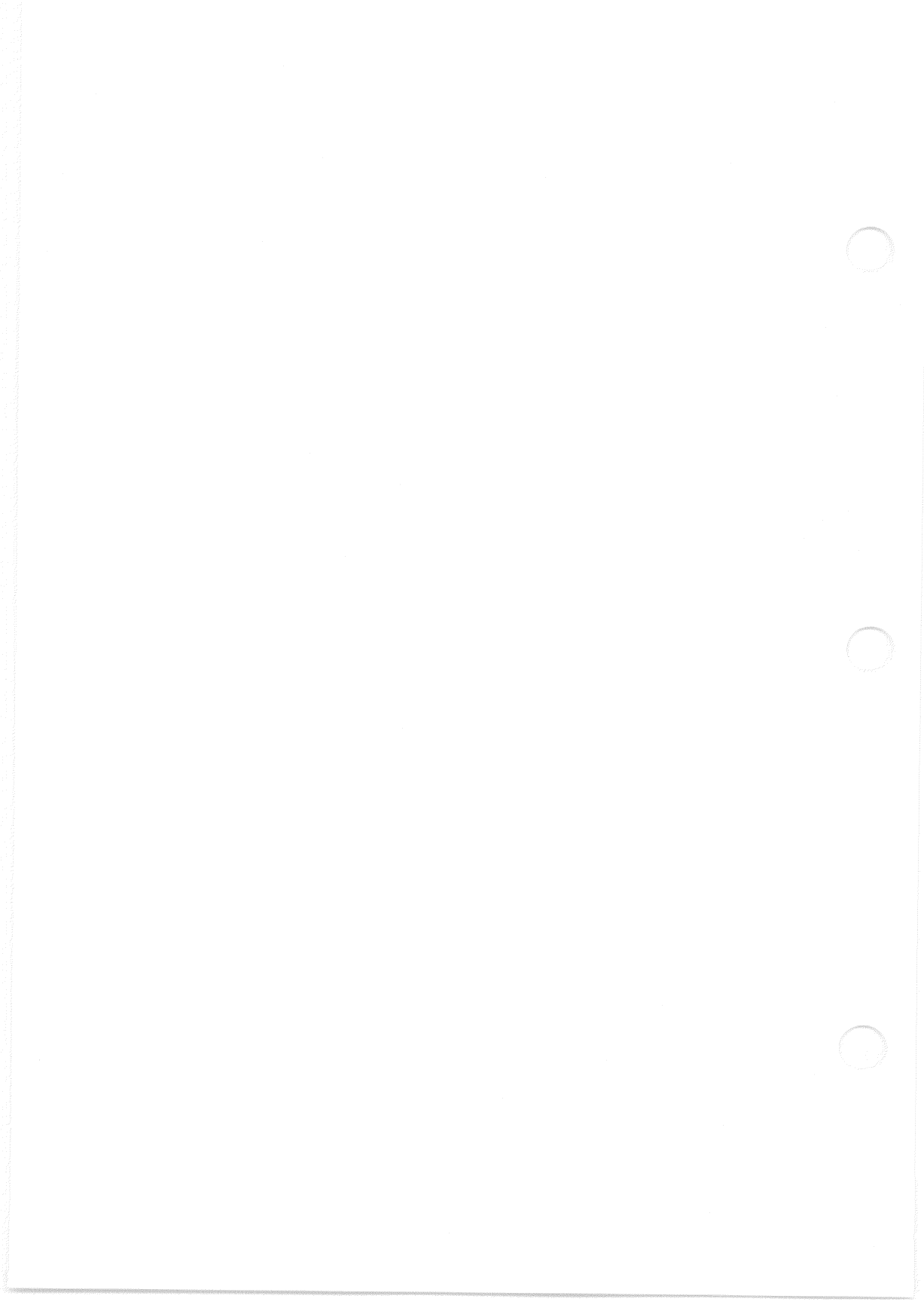

Preparing for Installation **1**

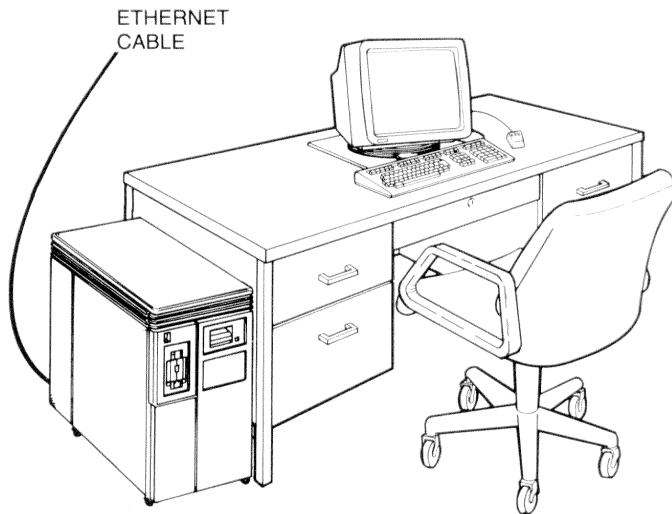

MLO-314-85

Figure 1-1: A Typical VAXstation II, BA123 Enclosure

CHECK YOUR SHIPMENT

Unpack the VAXstation II system and check your shipment against the packing list on the outside of one of your boxes. Your basic shipment consists of two cartons.

1. The VAXstation II system unit carton, with unpacking instructions on the outside, contains the following materials:

- Hardware Support Kit (Z4AAA), containing:

VAXstation II Hardware Information binder, housing:

VAXstation II Owner's Manual, BA123 Enclosure
VAXstation II Technical Manual, BA123 Enclosure

Appropriate media for testing and troubleshooting

- Accessories Kit, containing:

Installation and testing accessories, including a flat screw driver, a Phillips screw driver, a DEQNA loop connector, label sheets, and a grant card (for use by your support personnel)

- System unit power cord and any loopback connectors
- BC18P cable assembly with video cable
- VAXstation II system unit, BA123

2. The VAXstation II consolidation carton contains the following components:

- VR260 graphics monitor
- Monitor power cord
- Tilt-swivel base assembly
- LK201 keyboard with cable to connect to the monitor, feet for the keyboard, and an extra power cord
- VS10X mouse with cable to connect to the system unit

If you ordered media and documentation, you also receive a software carton, which contains the appropriate keyboard legend strips.

Check for optional items that you may have ordered, such as additional software or a printer.

If your shipment appears damaged, or if any item is missing, inform the delivery agent and contact your sales representative or the store where you purchased your system.

SITE-PREPARATION REVIEW

Before installing your system, review the following site-preparation requirements. You must provide:

- Adequate space for the system unit and peripherals
- Electrical power
- A suitable operating environment
- Accommodations for an Ethernet connection if you plan to connect the VAXstation II to a network

Review the Appendix, which provides VAXstation II system specifications, before you proceed with this chapter.

Space Planning

Leave sufficient space around the system unit and monitor to access the units and to allow air circulation through the units.

The System Unit — The vents on the system unit allow proper air flow. **Do not** cover the vents with items, such as books or paper.

The unit weighs approximately 130 pounds (59 kilograms).

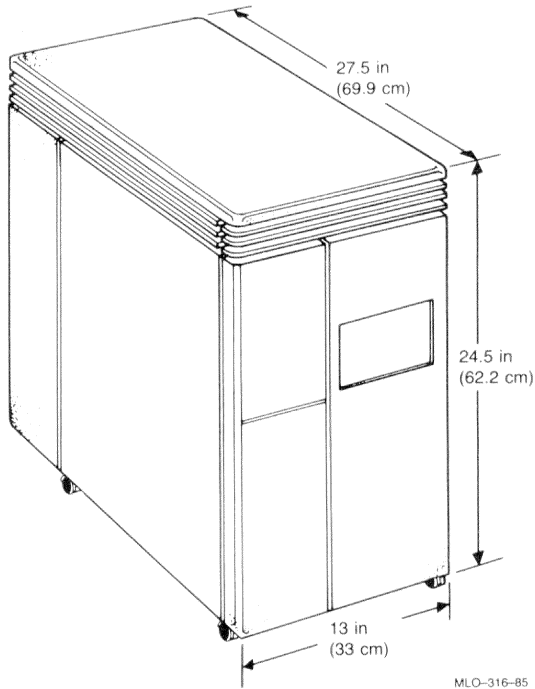
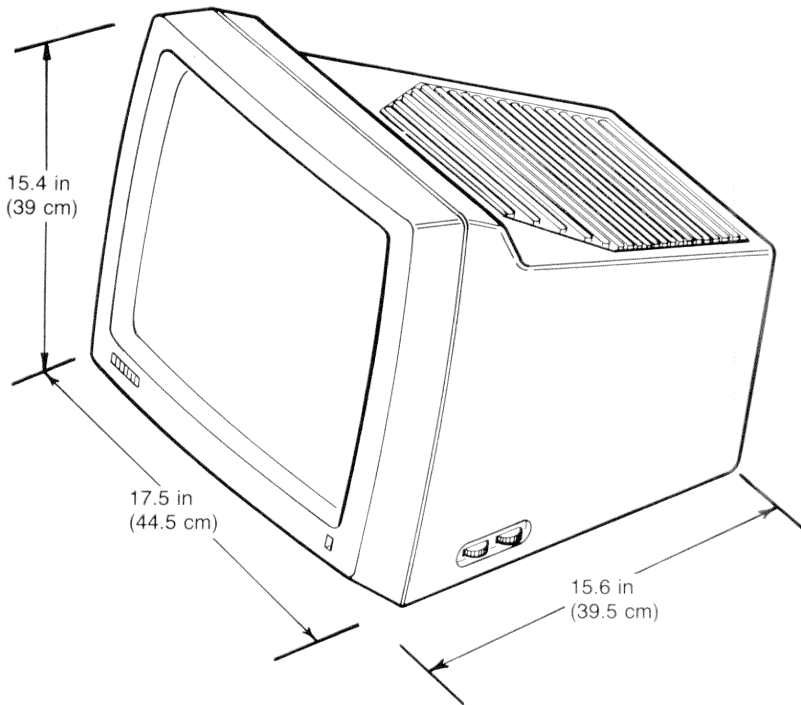

Figure 1-2: Dimensions of the System Unit

The Monitor — The vent on the top of the monitor allows proper air flow. **Do not** cover the vent with items, such as books or paper.

The monitor weighs approximately 40 pounds (18 kilograms).



MLO-317-85

Electrical Requirements

A 15-ampere branch circuit from the power distribution panel is recommended for each system. This circuit must meet national and local standards, provide a good system ground, be stable, and be free from electrical noise. If power disturbances cannot be prevented, you may need more power-conditioning equipment.

The ac power source should supply power to the original system and allow for system expansion. **Do not** connect other equipment (such as air conditioners, office copiers, or coffee pots) on the same circuit as that of the system unit or the monitor.

Preparing for Installation

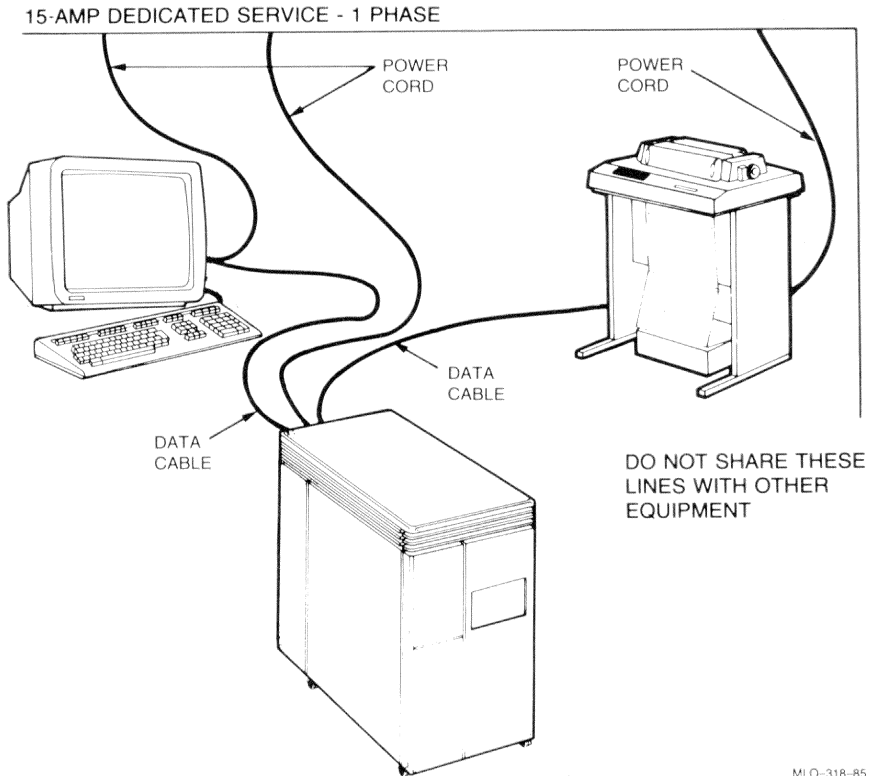

Environment

Temperature and Humidity — The location of the VAXstation II should have an environmental control system to maintain the recommended temperature and humidity. This system should filter and evenly distribute air to prevent hot spots.

The VAXstation II should not be located near heaters, photocopiers, or direct sunlight.

Static Electricity — Static electricity may cause a system to fail, data to be lost, and other problems to occur. The most common source of static electricity is the movement of people in contact with carpets and clothing. Low humidity results in the greatest buildup of static electricity. The following precautions reduce static buildup:

- Maintain greater than 40 percent relative humidity.
- Locate the system away from busy areas, such as office corridors.
- If a carpet is already fitted at the selected location, place antistatic pads under the system.

Clean Area — Dust particles can clog air passages inside the equipment, thus reducing the cooling air flow and diskette life, especially if the particles are abrasive. Keeping the system area clean and free from dust helps reduce those effects.

Do not place food or liquid on the system.

Supplies Storage — Store supplies, such as diskettes, at the same temperature and humidity levels as the system's.

Accommodations for an Ethernet Connection

The VAXstation II can be connected to an existing Ethernet network in two ways:

- through a DELNI
- through an H4000 transceiver

You require a BNE3X cable to connect a VAXstation II to a DELNI or to an H4000 transceiver. You may order this cable from DIGITAL. The transceiver cables of the BNE3X series come in four types:

- BNE3A – PVC, straight connector
- BNE3B – PVC, right-angle connector
- BNE3C – Teflon, straight connector
- BNE3D – Teflon, right-angle connector

For site-preparation information on Ethernet networks, see the following documents:

- *Ethernet Installation Guide* (Order No. EK-ETHER-IN-001).
- *DELNI Installation and Owner's Manual* (Order No. EK-DELNI-IN).

Setting Up the Hardware **2**

This chapter describes how to assemble, connect, and test the VAXstation II.

WARNING

When connecting any component of the VAXstation II system, set all power switches to the 0 (off) position.

SETTING UP THE SYSTEM UNIT

Make sure your system unit's location follows the site-preparation requirements in Chapter 1. To install the VAXstation II system, follow the steps in order or as directed. If you have trouble:

- Refer to Chapter 5 of this manual.
- Call the nearest DIGITAL Help Line. If you do not know this number, call 1-800-DEC-8000, and a DIGITAL representative will help you.

SETTING UP THE MONITOR

This section explains how to set up the VR260 monitor. It tells how to mount the monitor on the tilt-swivel base. The 15-inch x 15-inch tilt-swivel base allows you to turn the monitor 360 degrees. A pedal at the front of the base lets you slightly tilt the monitor up or down.

This section also explains how to attach the cable assembly. The cable assembly connects the monitor, keyboard, and pointing device to the system unit.

WARNING

Do not plug in the monitor power cord or turn on the monitor power switch until directed.

1. Make sure the monitor power switch is set to 0 (off).

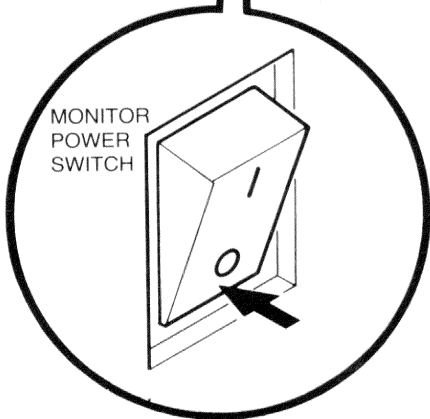

2. Place the monitor on a level surface. Position the monitor for ease of use.

The vent on the top of the monitor allows air flow. **Do not** cover the vent with items, such as books or paper.

WARNING

You will need two people to carry out this procedure. The monitor weighs 40 pounds (18 kilograms).

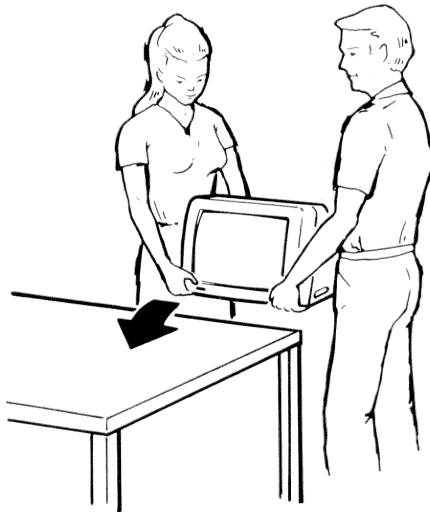

MLO-320-85

3. Locate the tilt-swivel base (Figure 2-1).

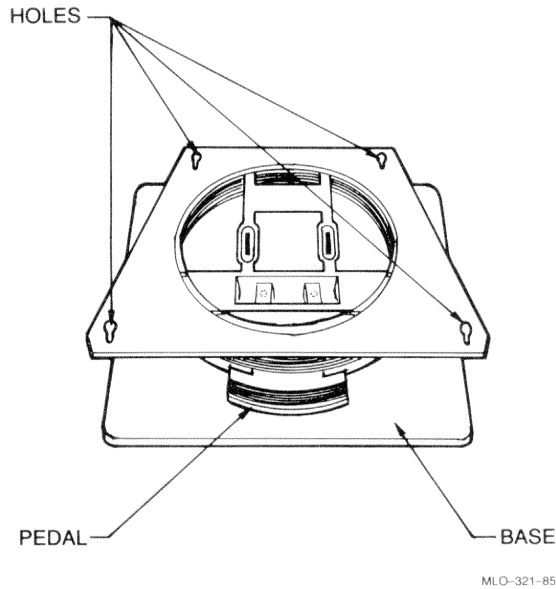

MLO-321-85

Figure 2-1: Tilt-Swivel Base Parts

4. To install your monitor on the tilt-swivel base:

- With the pedal facing forward, position the base next to the monitor.
- Loosen the monitor feet.
- Lift and position the monitor over the base.
- Lower the four monitor legs into the corresponding holes on the base.
- Push the monitor forward until it slides and locks into place.
- Tighten the monitor feet.

Figure 2-2 shows an installed tilt-swivel base.

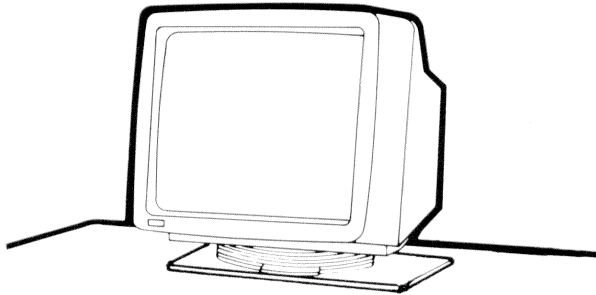

MLO-322-85

Figure 2-2: Installed Tilt-Swivel Base

Setting Up the Hardware

5. Locate the BC18P video cable assembly (from the system unit carton). Plug the connector into the socket at the far left of the back of the monitor and turn the connector clockwise to fasten.

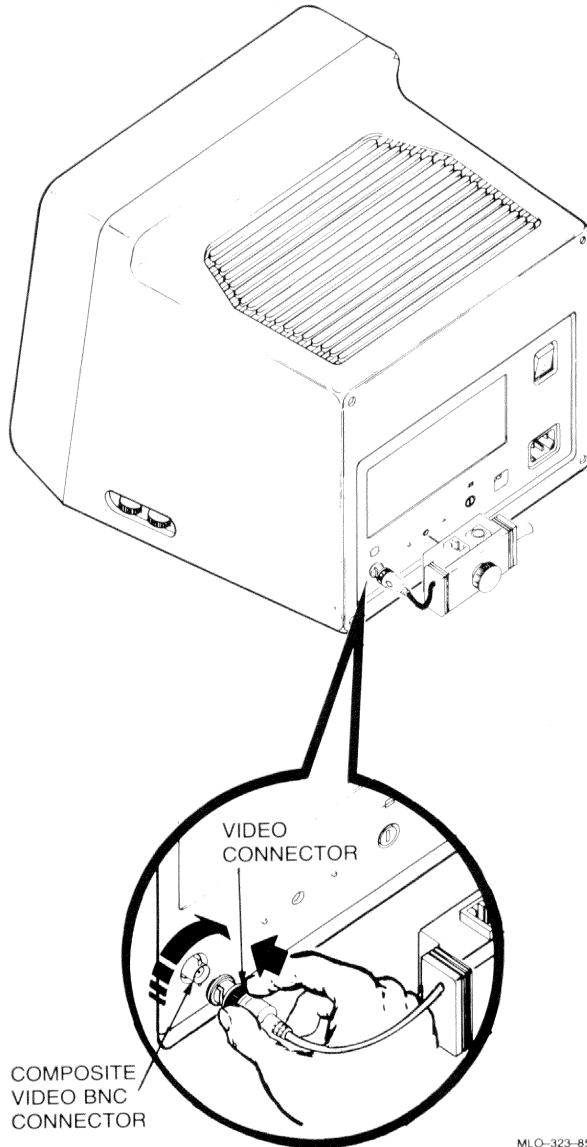

MLO-323-85

6. Align the stubs and the centering pin of the cable assembly with the holes to the right of the video cable connector and turn the knob clockwise to screw in the cable assembly.

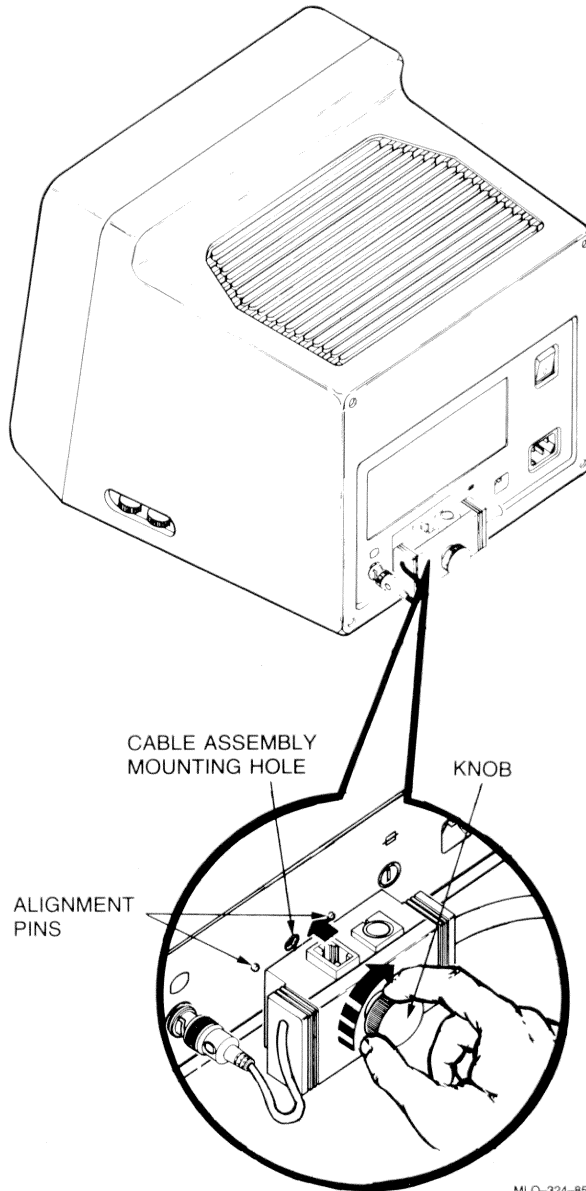

MLO-324-85

7. Check the **voltage select switch** setting on the monitor to make sure the setting matches the source voltage.

NOTE

DIGITAL sets the **voltage select switch** on a monitor for the country where the monitor will be installed. If the switch setting does not match the voltage you use, change the setting.

CAUTION

The monitor can be damaged if you do not set the **voltage select switch** correctly.

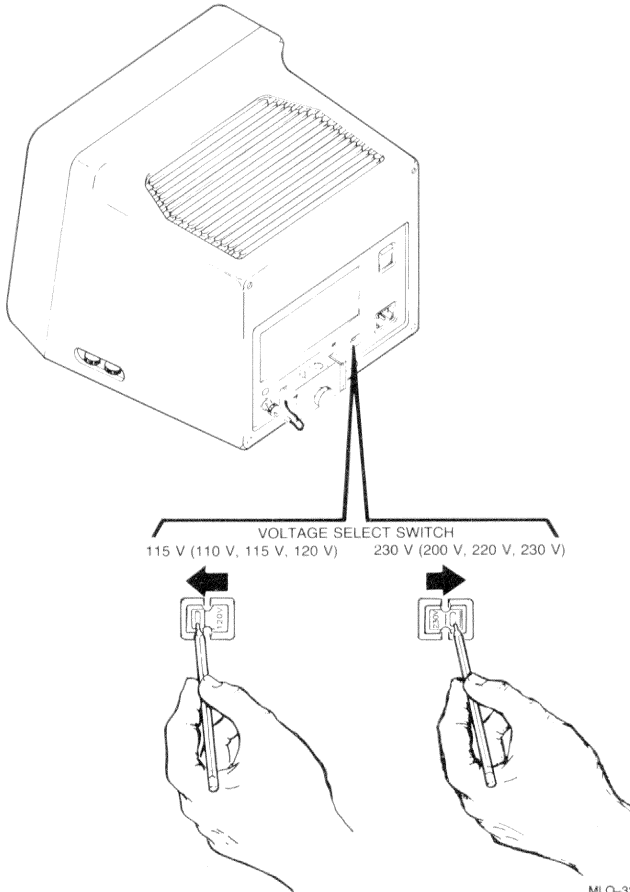

SETTING UP THE KEYBOARD AND POINTING DEVICE

1. Insert the legend strip (from the software carton) into the slot at the top of the keyboard.

KEYSTRIP
LEGEND SLOT

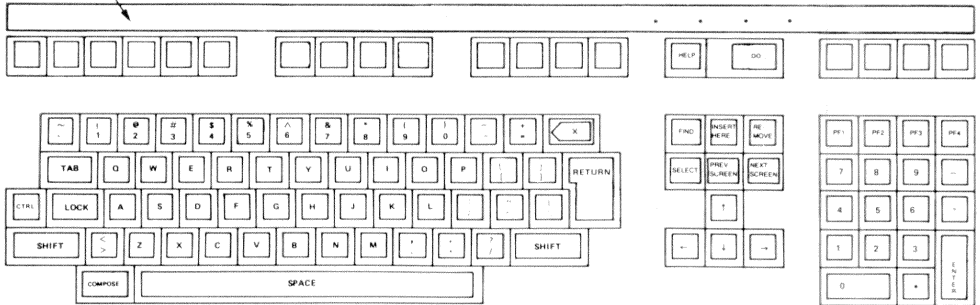

MLO-326-85

2. Install the keyboard feet.

Setting Up the Hardware

3. Connect the keyboard cable to the top left receptacle of the cable assembly.

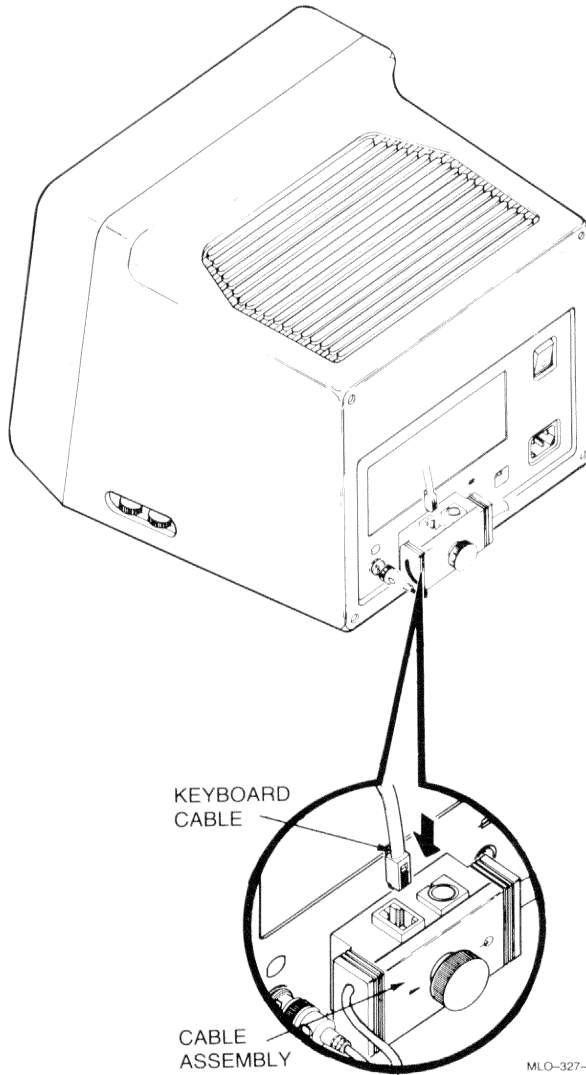

MLO-327-85

4. Locate the pointing device you wish to use. The pointing device may be either a mouse (standard) or a tablet (optional). Both devices may not be used at the same time.

If you want to use the mouse as your pointing device, proceed to step 5. If you prefer to use the tablet, proceed to step 6 (skip step 5).

5. Attach the mouse cable to the connector on the back of the system unit as illustrated. Tighten the screws. Proceed to the next section.

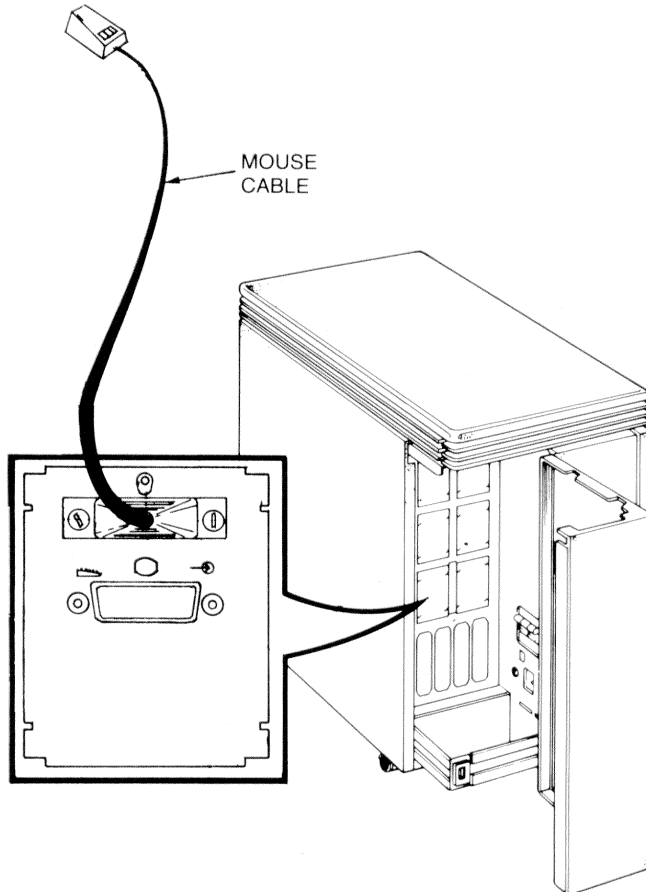

MLO-383-85

6. Plug the tablet cable into the round receptacle of the cable assembly.

NOTE

For proper operation, attach the puck or stylus before you connect the graphics tablet to the VAXstation II. The instruction sheet that comes with the tablet explains how to connect the various components. If you wish to change the puck or stylus, you must first disconnect the tablet from the VAXstation II. Then, swap the puck or stylus and reconnect the tablet to the system.

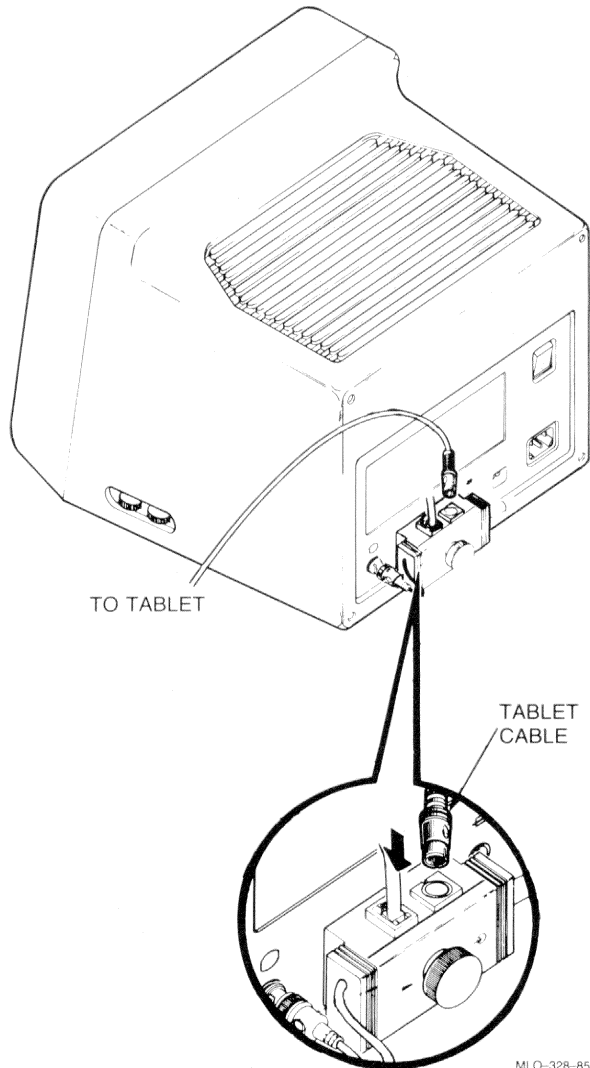

MLO-328-85

CONNECTING THE VAXSTATION II

This section covers the final steps to install your VAXstation II.

1. Locate the labels sheet in the installation accessories package.
2. Make sure that **all** buttons on the control panel of the system unit are out.

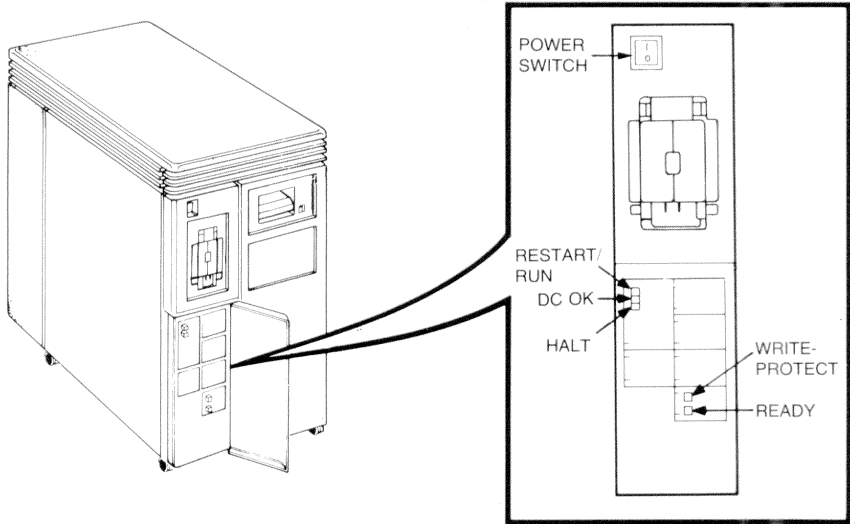

MLO-329-B5

3. Put the appropriate label on the control panel.
4. If your unit contains diskette drives, label them 1 and 2, respectively.

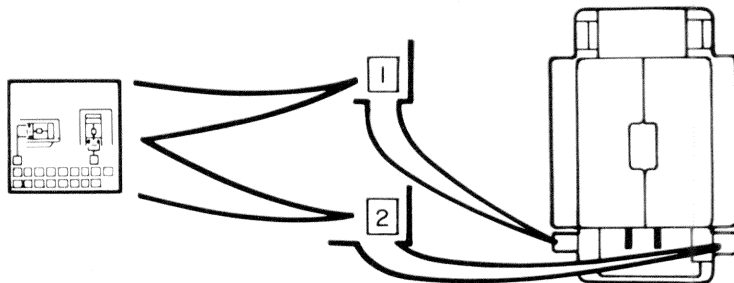

MLO-330-B5

Figure 2-3: VAXstation II System Unit Labels

Setting Up the Hardware

5. Open the door at the back of your system unit. A pop fastener holds the door in place.

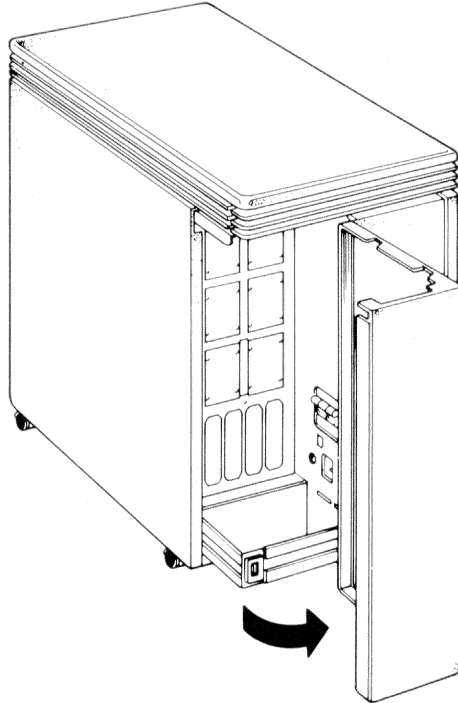

MLO-331-85

6. Set the controls located on the CPU distribution panel insert on the back of the system unit to the following positions:

- **Halt Enable/Disable** switch to the disable position (down)
- **Mode** switch to the middle (language inquiry) position
- **System unit baud rate** at 4800 baud

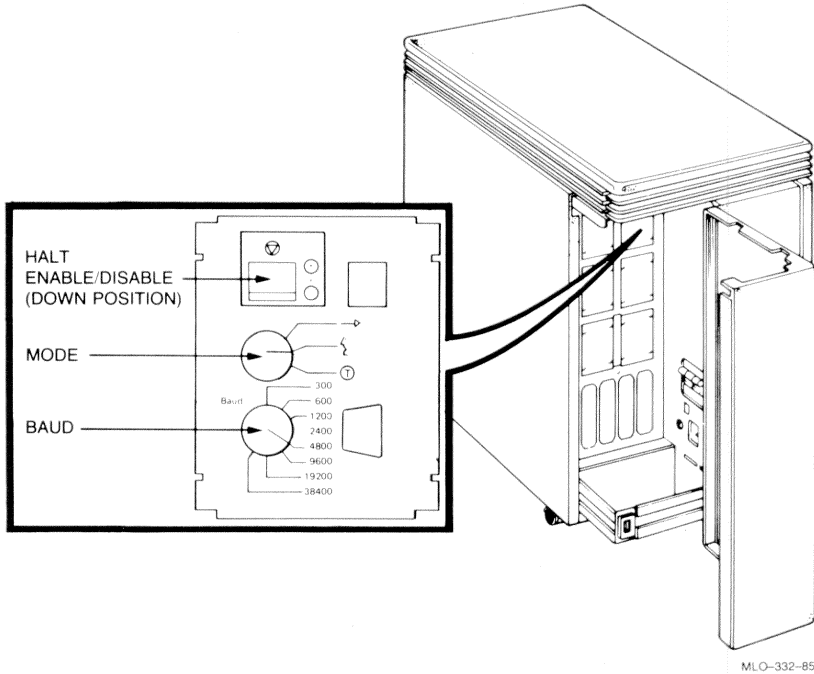

7. Connect the free end of the video cable to the back of the system unit.

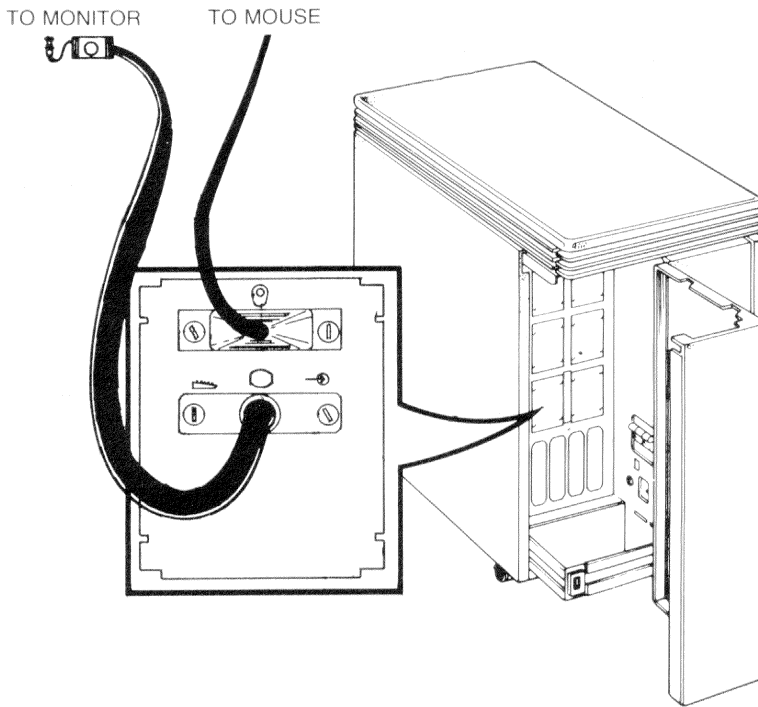

MLO-333-85

8. Connect the system to an Ethernet network (optional). The VAXstation II does not have to be connected to an Ethernet network to function, and if you do not wish to do so at this time, proceed to the next step.

You may connect the system to a DELNI yourself. However, you must call your service representative to connect the VAXstation II to an H4000 transceiver.

To connect the VAXstation II to the DELNI:

- A. Plug the male end of the BNE3X cable into the back of the VAXstation II.
- B. Plug the female end of the BNE3X cable into a free slot of the DELNI.

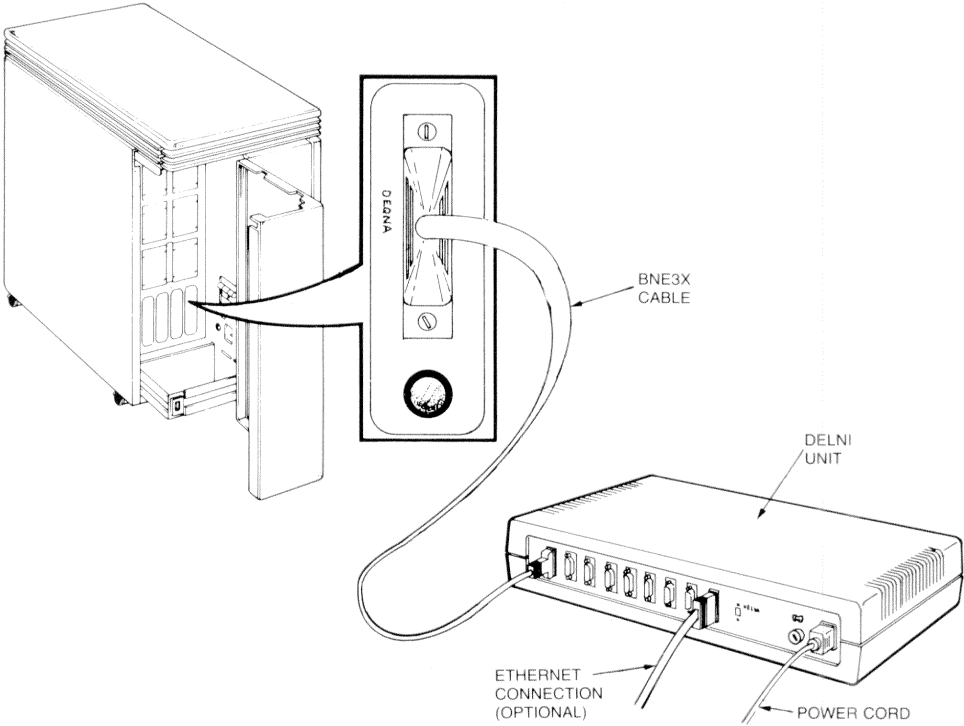

MLO-334-85

Figure 2-4: VAXstation II Connection to a DELNI

For more information on the DELNI, see:

- *DELNI Installation Guide and Owner's Manual* (Order No. EK-DELNI-IN).

9. Install and connect any options.

- Additional devices may include printers, external storage devices, and other options. The devices may be connected in any order.
- Read Chapter 4 for descriptions of the options and for VAXstation II installation information.
- Refer to the installation guide included with each optional device.

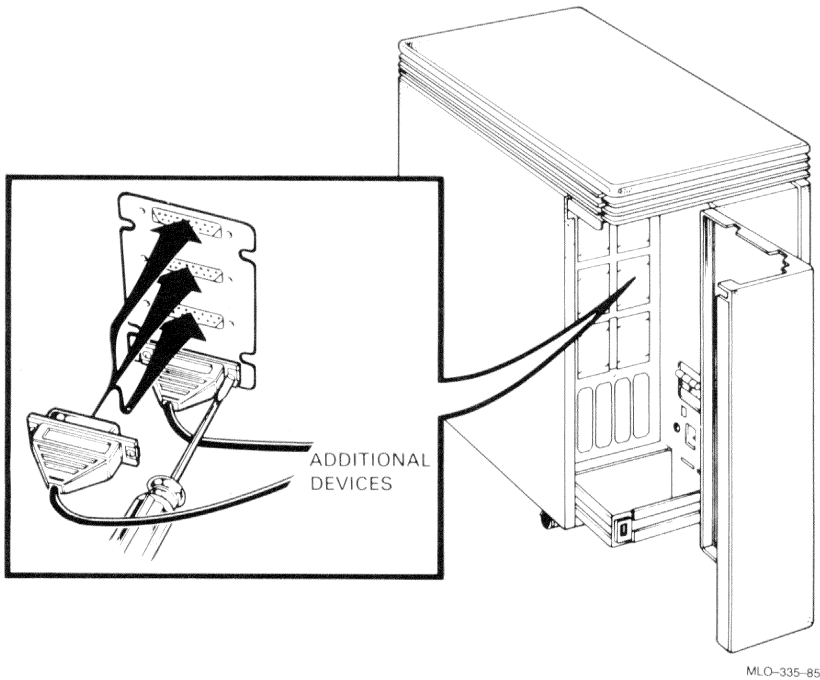

10. Identify the monitor and system unit power cords. Ensure that the plugs fit the wall outlet.

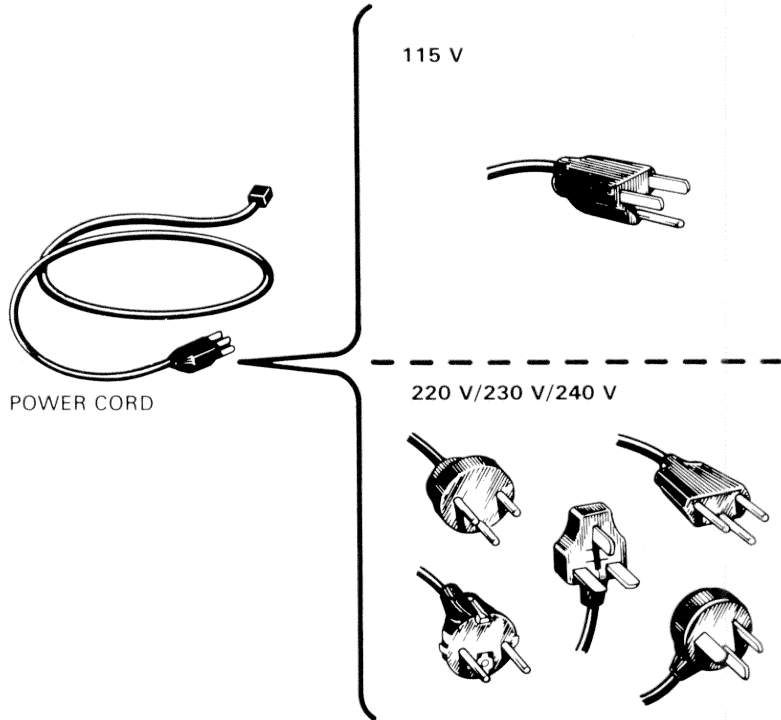

MLO-336-85

11. Read and remove the label covering the power connector of the system unit.

Check the voltage switch setting. If necessary, change the switch setting to match the voltage source.

CAUTION

An incorrect voltage switch setting will damage the VAXstation II system.

115 V
IN NORTH AMERICA,
THE VOLTAGE IS SET
TO 115 V.



220 V/230 V/240 V
IN OTHER COUNTRIES,
THE VOLTAGE IS SET
TO 230 V.
IF NOT, SLIDE
SWITCH TO 230 V.

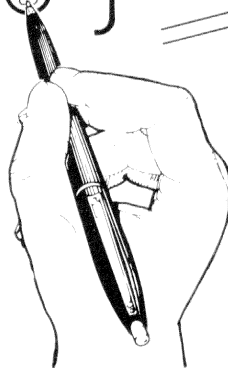

READ AND
REMOVE
CAUTION
LABEL

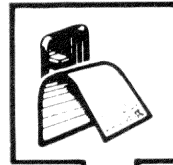

12. Before you connect the VAXstation II to a power source, make sure that the monitor power switch is set to 0 (off), the pushbuttons on the system unit front control panel are "out," and the power switch on the system unit front control panel is set to 0 (off). The power switch is located on the front of the VAXstation II system unit as illustrated below.

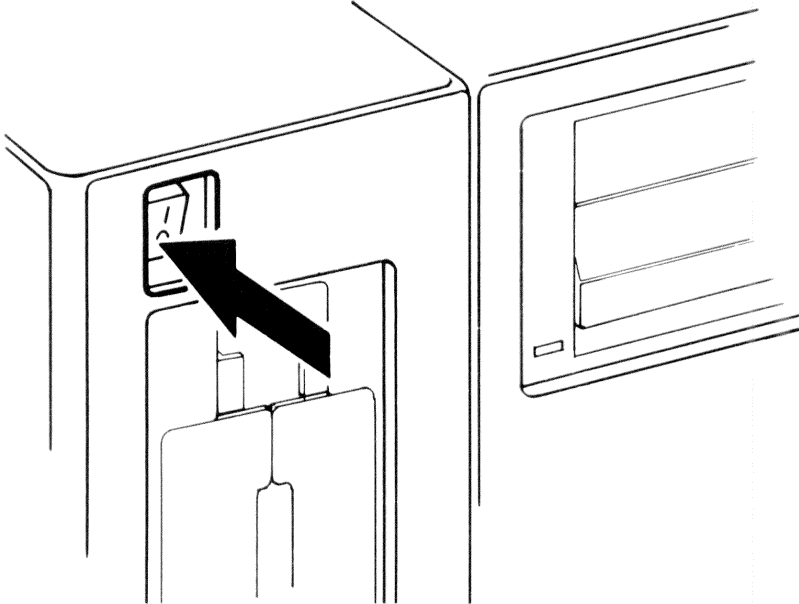

MLO-338-85

13. Connect the monitor power cord to the monitor first and then to an outlet.

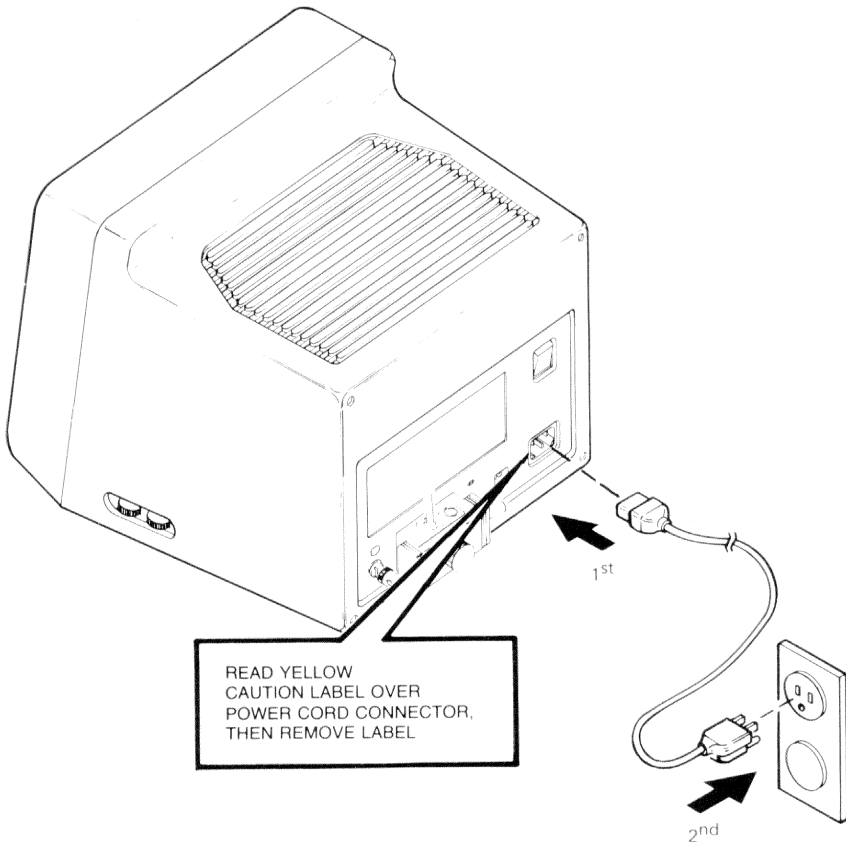

MLO-339-85

14. Plug in the ends of the system power cable.

- Plug one end firmly into the system unit power connector.
- Insert the other end of the system power cable into the wall receptacle.

Thread all the cables through the lower cable guide. Run the power and system interconnecting cables in areas where no one will trip over them. Avoid straining or bending the cables sharply.

Do not close the back door of the system unit.

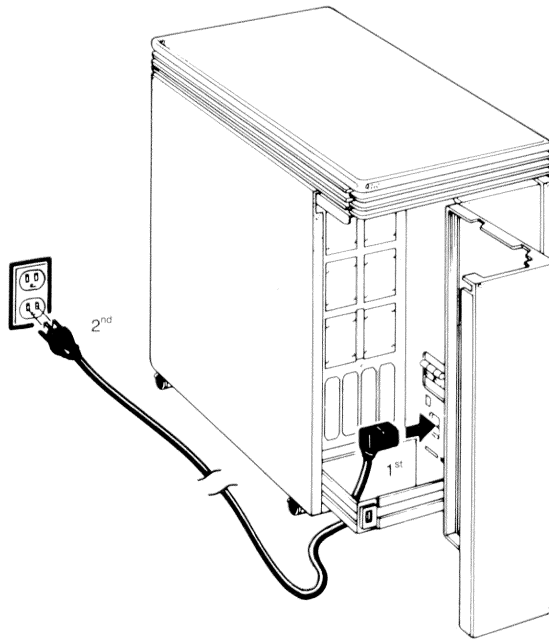

MLO-340-85

TESTING THE VAXSTATION II

The first time you power-up your system, follow the steps in this section to check the various components of your system.

Checking the Monitor

1. Power-up the system unit by setting the power switch to 1 (on).
2. Power-up the monitor by setting the power switch to 1 (on).

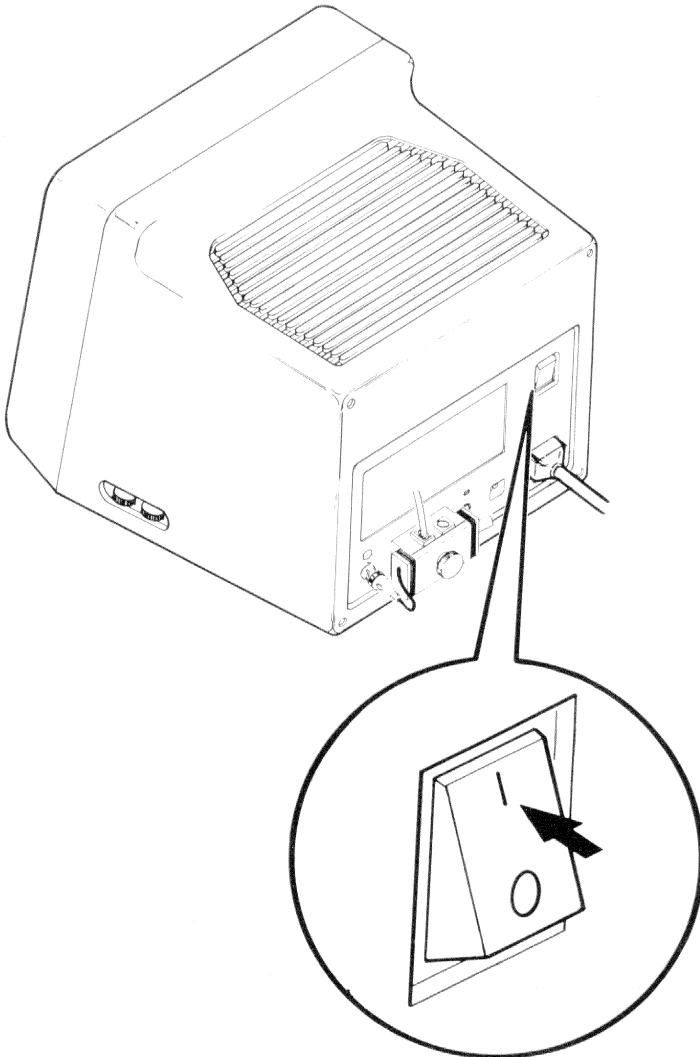

3. Check that the **power indicator** is lit green. If not, refer to Chapter 5.
4. Turn the **contrast** and **brightness controls** to maximum.
5. Wait about 30 seconds for a video display. If a video display does not appear, refer to Chapter 5.

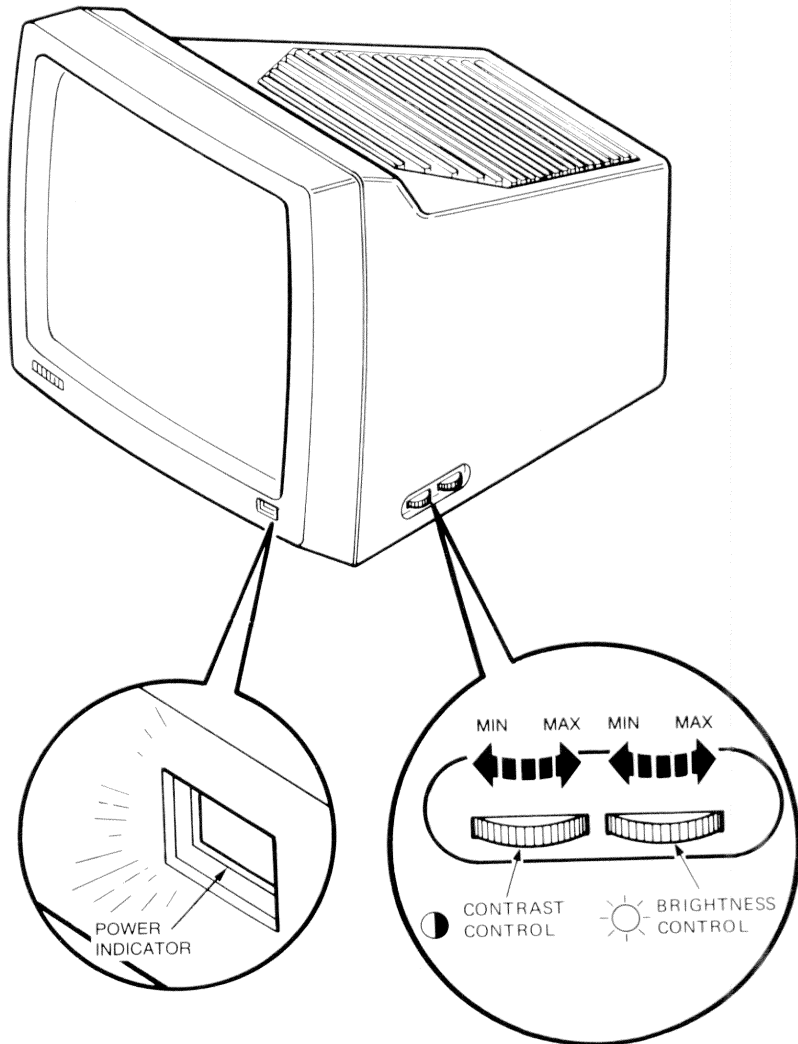

MLO-342-85

- Adjust the **brightness control** to minimum. Slowly turn up the **brightness control** to your viewing preference. If horizontal lines (raster) appear on the screen, you have gone too far and should start this step again. Adjust the **contrast control** to a level you like.

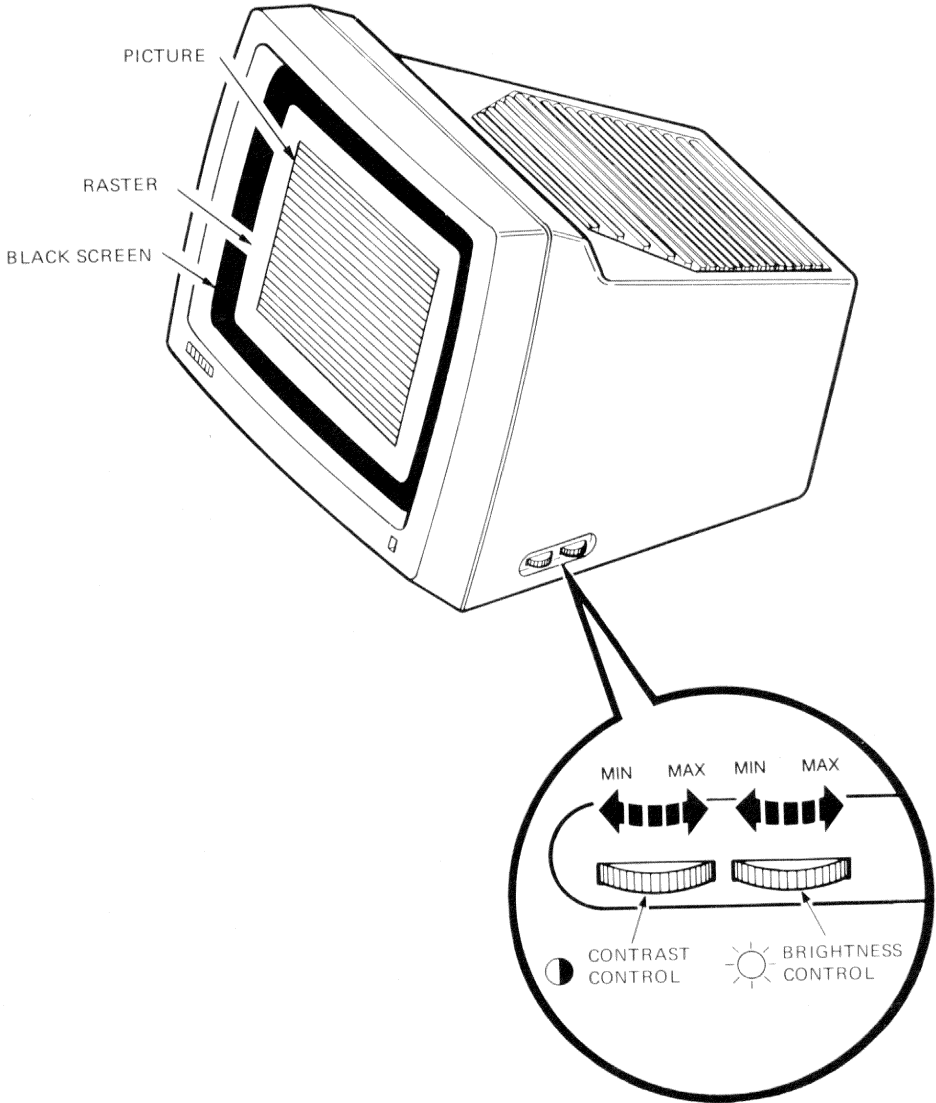

MLO-343-85

Checking the System

Testing your system consists of turning on the system, selecting a language mode, and executing *MicroVAX Maintenance System* software.

1. Push the **Fixed Disk Ready** pushbutton on the control panel to put the fixed disk off line.

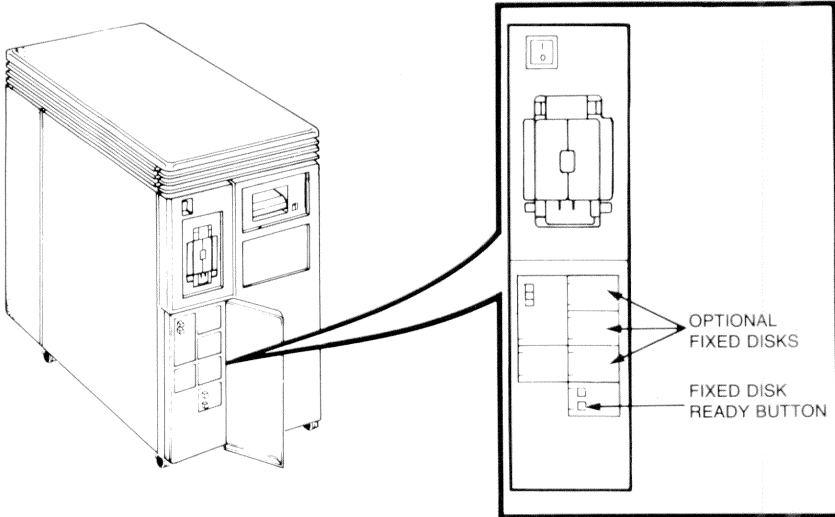

MLO-344-85

Your system contains either an RX50 diskette drive or a TK50 tape drive. If your system has a diskette drive, proceed with step 2.

If your system has a tape drive, proceed to step 4 (skip steps 2 and 3).

Setting Up the Hardware

2. Find the diskettes labeled *MVII Diag. Cust. RX50* in the diskette holder at the front of this binder.

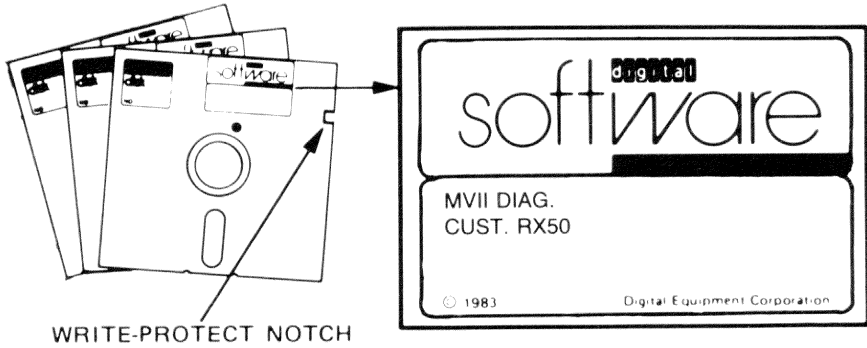

MLO-344A-85

3. Insert the diagnostic diskette labeled #1 in drive 1.
 - A. Open drive 1.
 - B. Aligning the orange arrow on the diskette with the orange stripe on the drive, insert the diskette.
 - C. Close drive 1.
 - D. Set the power switch to 1 (on) and proceed immediately to step 6 (skip steps 4 and 5).

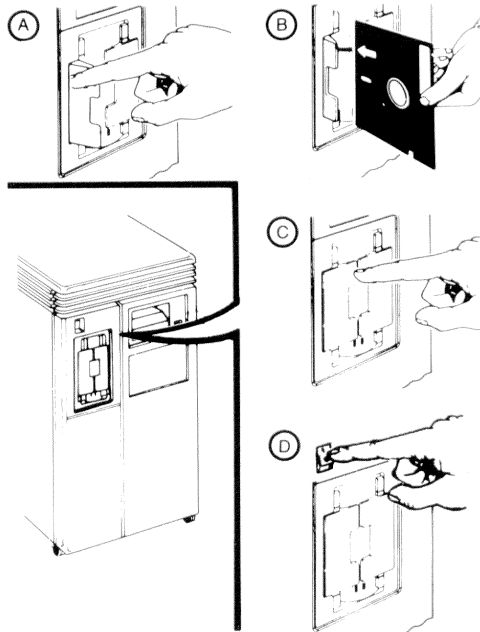

MLO-345-85

NOTE
Each diskette drive contains a cardboard shipping card.
Remove this card prior to diskette insertion.

Setting Up the Hardware

4. Find the tape cartridge labeled *MVII Diag. Cust. TK50* in the cartridge holder at the front of this binder.

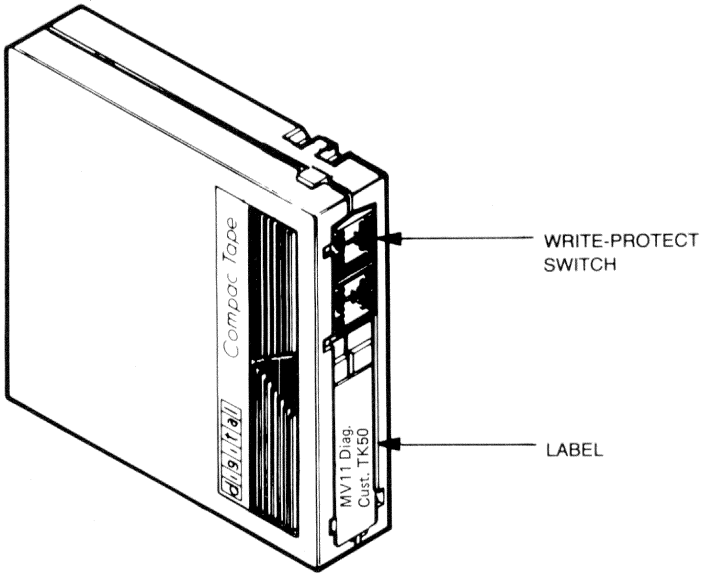

MLO-345A-85

5. Insert the tape cartridge into the tape drive.

- A. Set the power switch to 1 (on). You will not be able to move the **cartridge release handle** if the power switch is set to 0 (off).
- B. After the indicator illuminates green, open the tape drive by lifting up the **cartridge release handle**.
- C. With the arrow on the tape cartridge facing up, insert the tape cartridge into the tape drive.

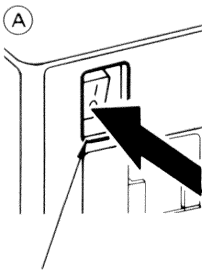

POWER SWITCH

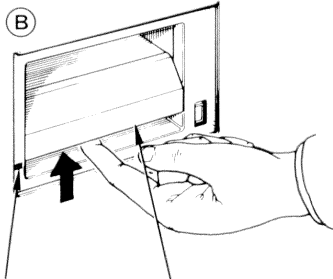

GREEN INDICATOR LIGHT IS LIT

CARTRIDGE RELEASE HANDLE

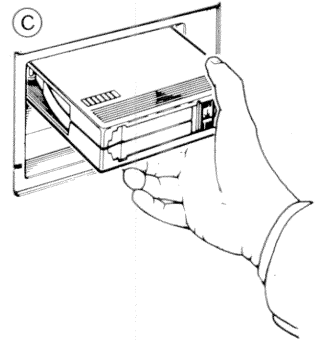

D. Push down the **cartridge release handle**.

- E. Push the **Load/Unload** button to the in position. The button illuminates red. When the indicator illuminates green, the tape is ready for use.

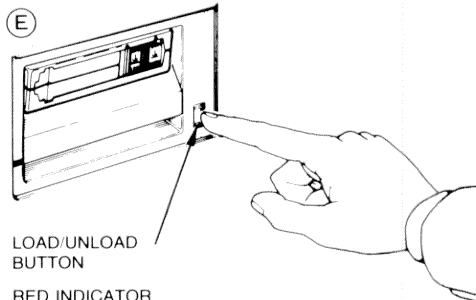
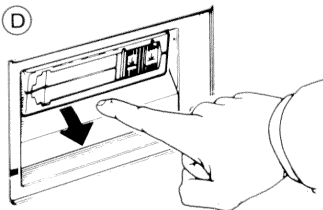

LOAD/UNLOAD BUTTON

RED INDICATOR LIGHT IS LIT

MLO-346-85

CAUTION

Do not lift the **cartridge release handle** unless the **Load/Unload** button is not lit red and the indicator illuminates green. Do not lift the **cartridge release handle** while a light flashes.

NOTE

For a more detailed discussion of the TK50 tape drive controls and procedures, refer to Chapter 3 of this manual.

6. Check that the language selection menu appears on the monitor. If you do not see this display, go to Chapter 5.

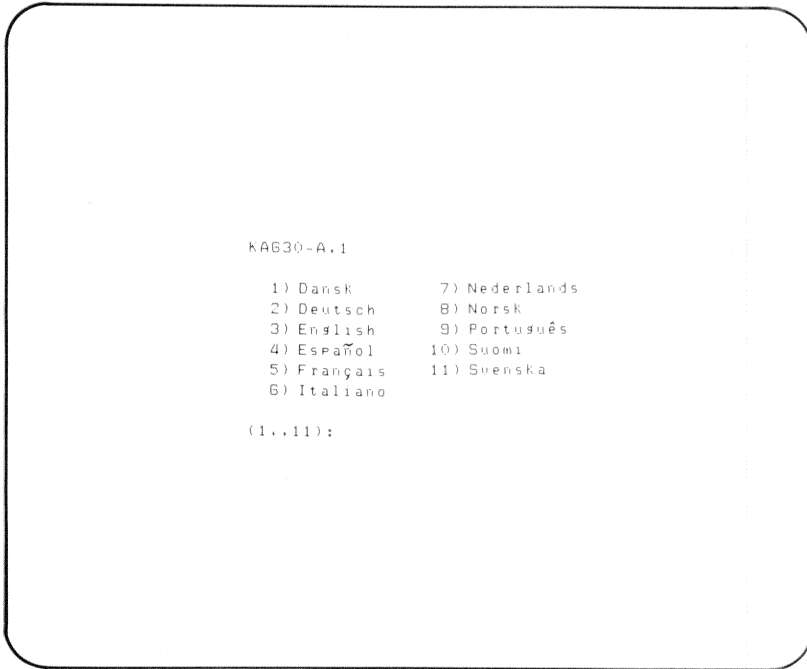

MLO-347-85

7. Select the language to match your keyboard by pressing the corresponding number key and then pressing the RETURN key.

If you select English, French, or German, a second menu appears. Select which variant of the language you prefer to use. Example: for English, you have a choice of:

- United Kingdom
- United States/Canada

A few moments after selecting the language, you see the following power-on display:

```
Performing normal system tests.  
7..6..5..4..3..  
Tests completed.  
Loading system software.  
2..1..0
```

MLO-348-85

The terminal slowly displays the numbers 7 through 3, indicating completion of steps in the power-on test.

The last part of the display contains the numbers 2 through 0, indicating that the system is loading *MicroVAX Maintenance System* software. A few moments later, the introductory display of the *MicroVAX Maintenance System* appears.

```
MicroVAX Maintenance System - Version 2.0

                CONFIDENTIAL DIAGNOSTIC SOFTWARE
                PROPERTY OF
                DIGITAL EQUIPMENT CORPORATION

                Use Authorized Only Pursuant to a Valid Right-to-Use License

Copyright (c) 1985
Digital Equipment Corporation

Current date and time is: 15-SEP-1985 13:30:10

Press the RETURN key to continue
OR enter new date and time, then Press the RETURN key.

[DD-MMM-YYYY HH:MM]: >
```

MLO-349-85

8. Make sure the date and time in the introductory display are accurate. If the date and time are accurate, press RETURN to continue.

If the date and time are inaccurate or "not known," type the correct date and time, following the format as shown. An example is 15-SEP-1985 13:30:10. Press RETURN to continue.

The test preparation display appears and tells you the system is preparing for testing. This process takes a few minutes.

If you have an RX50 diskette drive, text instructs you to remove the diskette labeled #1 and insert the diskette labeled #2. The system informs you if additional diskettes are required to complete testing.

9. When the diagnostics are loaded, text tells you to remove the diskette or tape cartridge you are using and to press RETURN.

The monitor displays the **Maintenance System Main Menu** display. Chapter 5 contains a description of this menu.

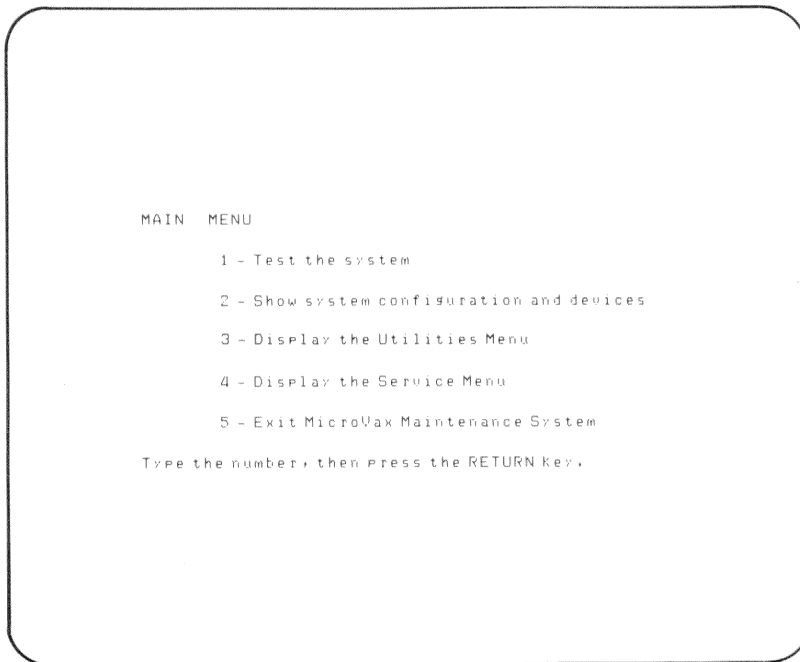

MLO-350-85

Figure 2-5: Maintenance System Main Menu

10. Save the language you selected in step 7.

- Rotate the **Mode** switch counterclockwise to the next position.
- Close the back door of the system unit.

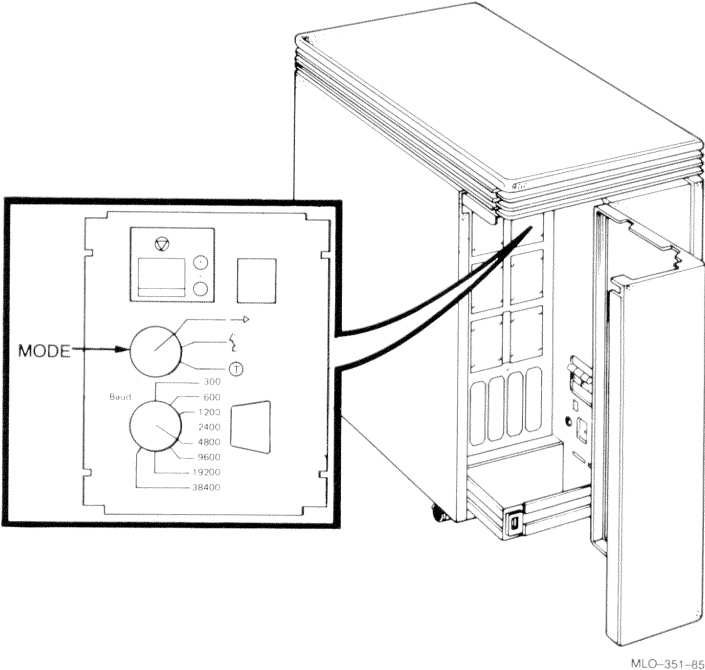

MLO-351-85

11. Select the **Test the System** diagnostic by typing 1 and then pressing RETURN.

A few moments later, the monitor displays the **System Test** screen.

SYSTEM TEST

This is a test of the MicroVAX computer and its devices.
No Preparation for this testing is required; the MicroVAX
is ready to be tested.

Testing occurs in two parts: the functional tests quickly
test each device sequentially; the exerciser test (lasting
about 4 minutes) tests how the devices work together.

To halt the test at any time and return to the Main Menu,
type ^C by holding down the CTRL key and pressing the C key.

Press the RETURN key to begin testing,
OR type 0 and Press the RETURN key to return to the previous menu.

MLO-352-85

12. Press RETURN to begin testing.

The monitor displays several messages to inform you of the progress of the system tests. After about 4 minutes, a message telling you the system has passed the testing appears on your screen.

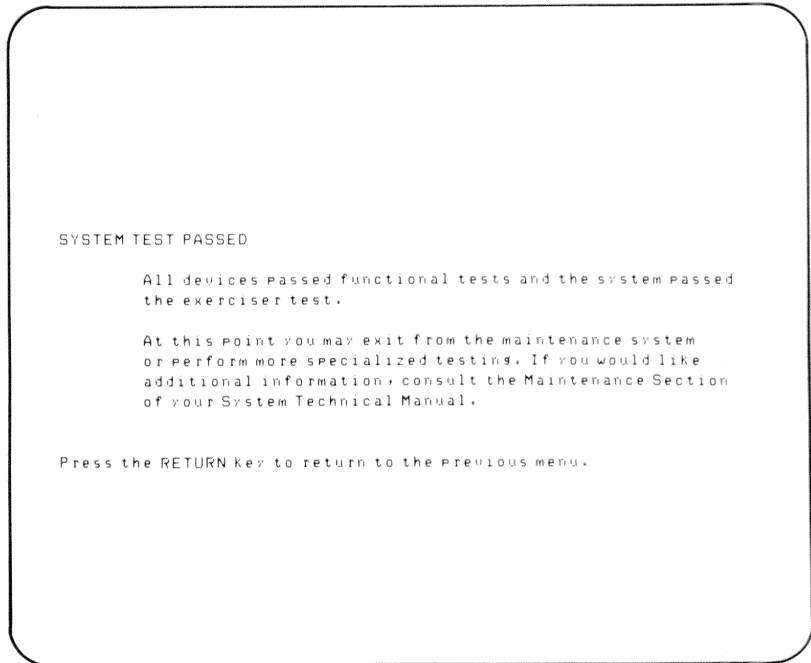

You have successfully installed and tested your VAXstation II system.

NOTE

If you see error messages, refer to the *VAXstation II System Technical Manual*.

13. Press RETURN to get back to the **Main Menu**. The **Main Menu** (Figure 2-5) is displayed. The other diagnostic tests shown on this screen are explained in Chapter 5.

14. Type 5 and press RETURN to exit the **Main Menu**. The monitor displays the following screen:

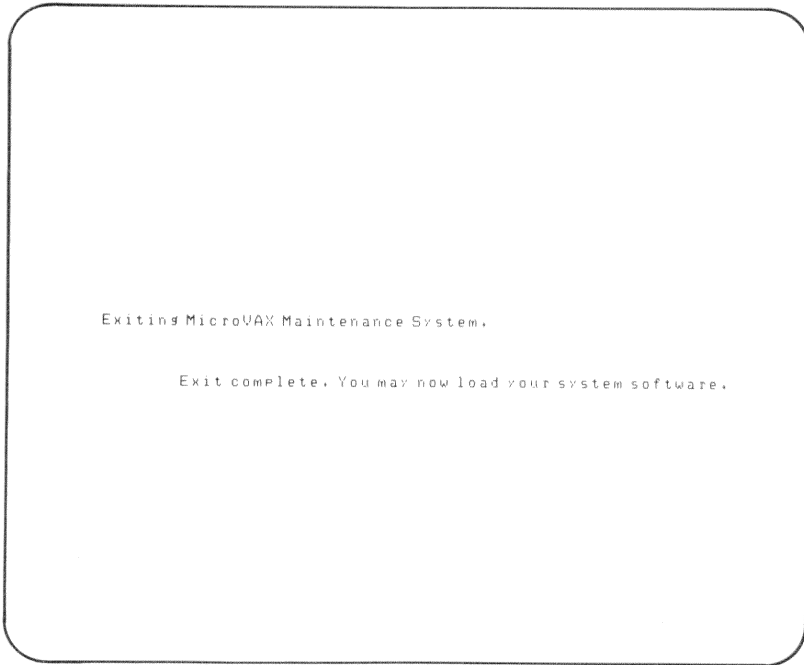

MLO-354-85

15. Push the **Fixed Disk Ready** pushbutton on the control panel to put the fixed disk back on line.

WHERE TO GO FROM HERE

You may now install software on your VAXstation II. The software installation instructions are in the VAXstation II software carton.

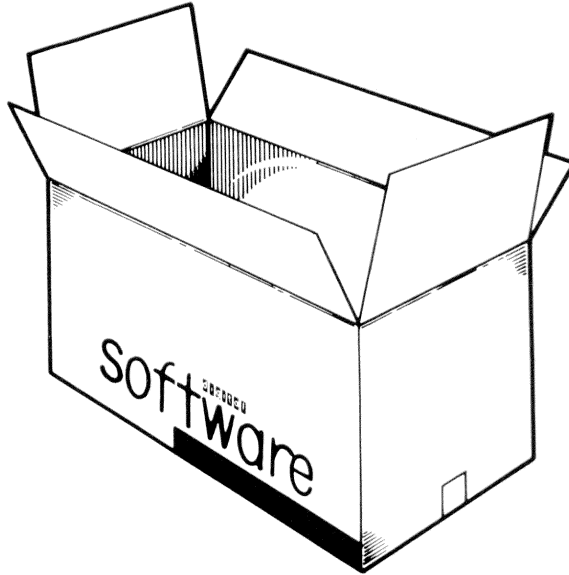

MLO-355-85

After you have installed the software, proceed to Chapter 3 of this manual, which covers system operation.



This chapter contains information on the following topics:

- VAXstation II controls and indicators
- Turning on the VAXstation II
- Turning off the VAXstation II
- VR260 monitor controls and indicators
- RD52 or RD53 fixed disk
- DEQNA communications module
- RX50 dual diskette drive and diskettes
- TK50 tape drive and tapes
- Making back-up copies

VAXSTATION II CONTROLS AND INDICATORS

The front control panel (Figure 3-1) contains the following controls and indicators:

- System power switch
- Restart/Run pushbutton
- DC OK indicator
- Halt pushbutton

- Fixed disk write-protect pushbutton
- Fixed disk ready pushbutton

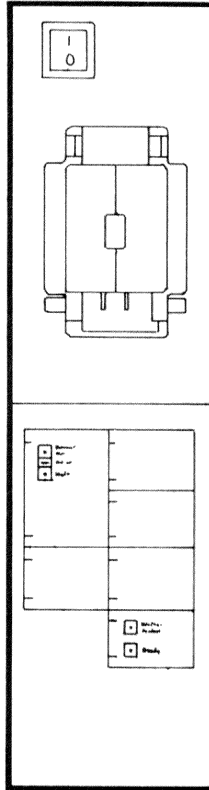

MLO-356-85

Figure 3-1: Controls and Indicators

Additional controls and indicators, not used for normal system operation, are located on the CPU distribution panel on the back of the VAXstation II cabinet. Those controls are described in the *VAXstation II System Technical Manual*.

The System Power Switch and Indicators

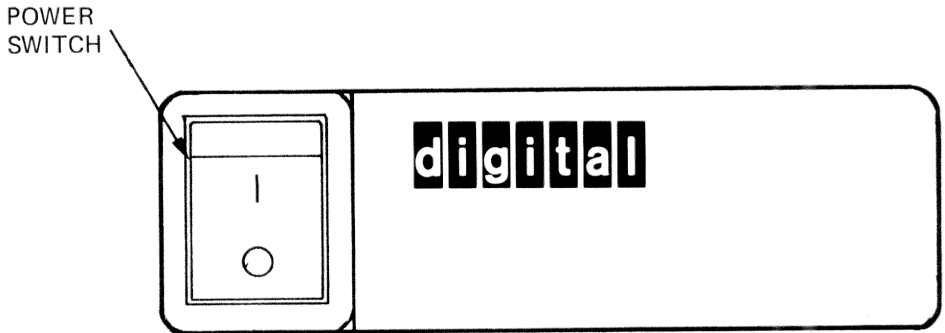

MLO-357-85

The system **power switch** turns on and off the ac power. Setting the switch to 1 turns on the power.

The **Restart/Run** pushbutton glows green when the CPU is operating. The **DC OK** indicator glows green when the power supply is generating the correct voltages.

Setting the **power switch** to 0 turns off the power. When power is switched off, the **Restart/Run** pushbutton and the **DC OK** indicator extinguish.

The Restart/Run Pushbutton

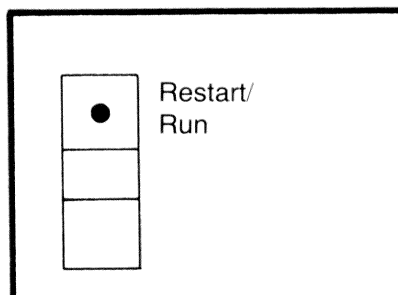

MLO-358-85

The **Restart/Run** pushbutton can be used as a momentary control to reboot computer operation. When pushed, the button restarts the system. Work in progress is lost. See the *VAXstation II Technical Manual* for more information.

When the system is on, the **Restart/Run** pushbutton glows green to indicate normal software operation. If it does not glow, refer to Chapter 5 for suggestions.

The DC OK Indicator

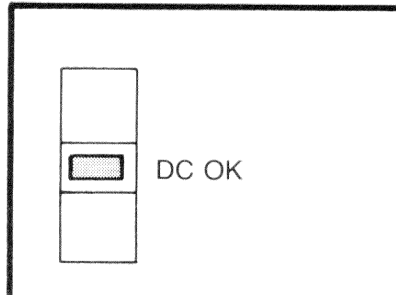

MLO-359-85

The **DC OK** indicator glows green when the system is generating power. If it does not glow, the system is not generating power. Refer to Chapter 5 for troubleshooting suggestions.

The Halt Pushbutton

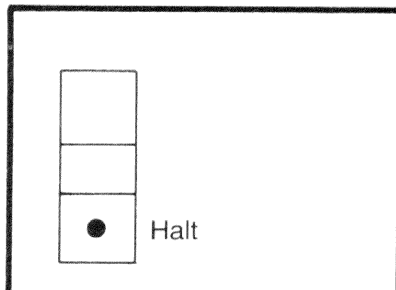

MLO-360-85

The **Halt** pushbutton stops the program currently running without shutting down the VAXstation II.

When the **Halt** pushbutton is pressed, it latches in and glows red. You must press the pushbutton again to release it, putting the VAXstation II into the console mode. See the *VAXstation II System Technical Manual* for a description of the console commands.

The pushbutton should be set in the out position and not lit to allow for software operation.

The **Halt Enable/Disable** switch (on the back of the VAXstation II cabinet) is normally set to the down (disable) position. This position prevents the system from going into console mode when you execute a halt in a program. It also stops devices (such as a printer) connected to the auxiliary port from halting the processor.

The Fixed Disk Pushbuttons

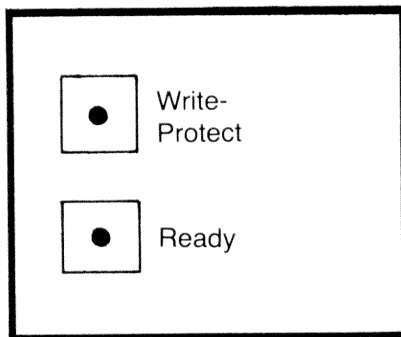

MLO-361-85

The system contains one or more fixed disks, each with its own pushbuttons.

The **Fixed Disk Write-Protect** pushbutton is set in the out position and not lit for normal software operation. System software can read or write information on the disk. To write-protect the disk, preventing system software from erasing or writing on the disk, push in the **Write-Protect** pushbutton. The pushbutton illuminates orange.

The **Fixed Disk Ready** pushbutton illuminates green when it is set to the out position and indicates the fixed disk is ready to store information. When pushed in, the pushbutton is not lit, and the fixed disk is disabled. In effect, it is turned off.

TURNING ON THE SYSTEM

The procedure for turning on the VAXstation II assumes that it has been installed according to the Installation section of this manual and that the

system software has been installed. If the system software has not been installed, install it as directed in the documentation supplied with it.

Initial Control Panel Switch Settings

1. Set the **Fixed Disk Ready** pushbutton to the out (ready) position.
2. Set the monitor power switch to 1 (on).
3. Set the power switch on the system unit to 1 (on) position.

When you turn on the power, the VAXstation II control panel indicators appear as described in Table 3-1.

Table 3-1: Normal Power-On Indications

Control/ Indicator	Normal indication
Power Switch	Glows red
DC OK	Glows green
Fixed Disk Ready	Glows green within 30 seconds
Tape Drive Load/Unload	Glows red for 2 seconds and then goes out

If you do not observe the normal indications listed in Table 3-1, refer to Chapter 5 for troubleshooting information. The monitor begins to display the power-up screen.

The monitor slowly displays the numbers 7 through 3, indicating completion of steps in the power-up system test. The VAXstation II performs power-on system tests each time you turn on the system.

Then, the monitor displays the numbers 2 through 0 to indicate that the VAXstation II system is loading the system software. The first screen for the system software appears on the monitor after a few seconds.

The VAXstation II system is now ready for use. Refer to the system software documentation for further instructions on using the VAXstation II system.

TURNING OFF THE SYSTEM

To prevent loss of data, follow the system shut-down procedure described in your system software documentation. That procedure insures an orderly system shutdown.

Turn off the VAXstation II system by setting the power switch to 0 (off).

VR260 MONITOR CONTROLS AND INDICATORS

The front and side of the monitor have three status controls and indicators:

The **Power Indicator** illuminates to indicate that power is supplied to the monitor in the correct amount.

The **Contrast Control** allows you to adjust the contrast of the monitor screen.

The **Brightness Control** allows you to lighten or darken the monitor screen.

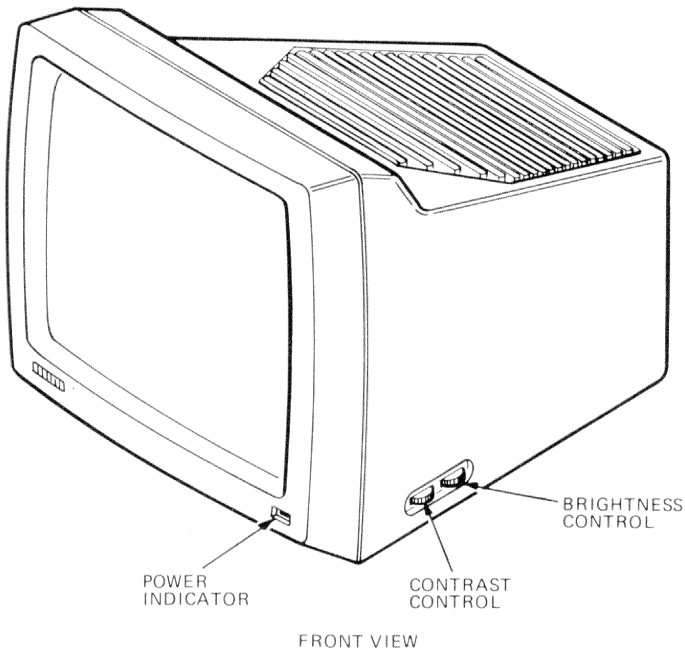

Figure 3-2: Front and Side Controls

The back of the monitor has the following five connectors and controls:

1. Composite Video BNC Connector
2. Fuse
3. Voltage Select Switch
4. AC Power Input Connector
5. Power Switch

The video cable plugs into the **Composite Video BNC Connector** and the cable assembly.

The monitor, keyboard, and pointing device are joined to the system unit through the video cable assembly, which screws into the **Cable Assembly Mounting (Gold) Hole**.

The **Fuse** protects the monitor from electrical damage.

The **Voltage Select Switch** lets you match the monitor voltage to the wall outlet voltage.

The monitor power cord plugs into the **AC Power Input Connector**.

The **Power Switch** enables you to turn on or off the monitor. Press 1 to turn on the power. Press 0 to turn off the power.

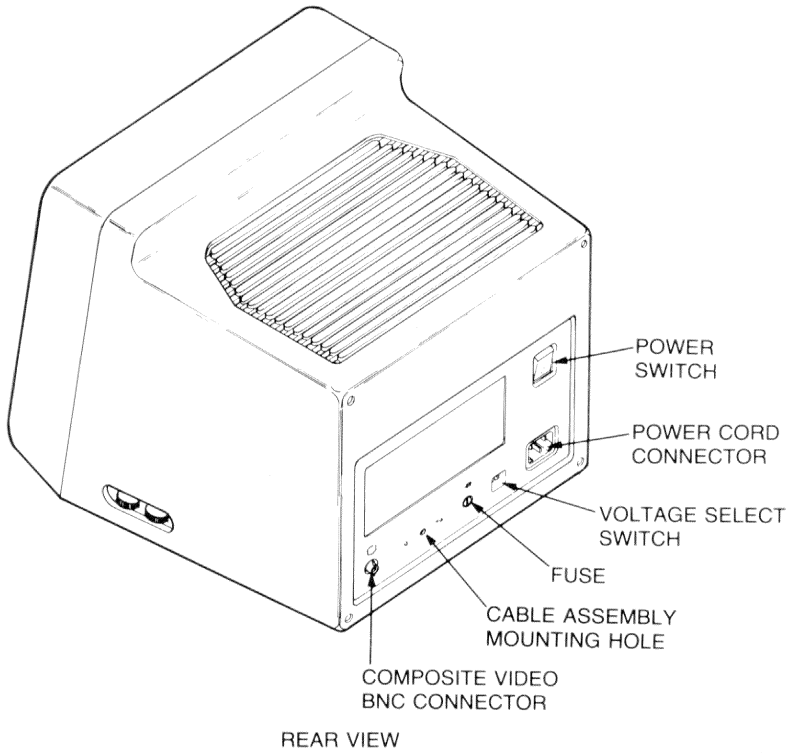

MLO-364-85

Figure 3-3: Rear Controls and Connectors

THE RD52 OR RD53 FIXED DISK DRIVE

The fixed disk drive located inside the cabinet stores information on a non-removable disk.

The RD52 fixed disk stores up to 31 megabytes of data. The RD52 is usually configured with the RX50 diskette drive.

The RD53 fixed disk stores up to 71 megabytes of data. The RD53 is usually configured with the TK50 tape drive.

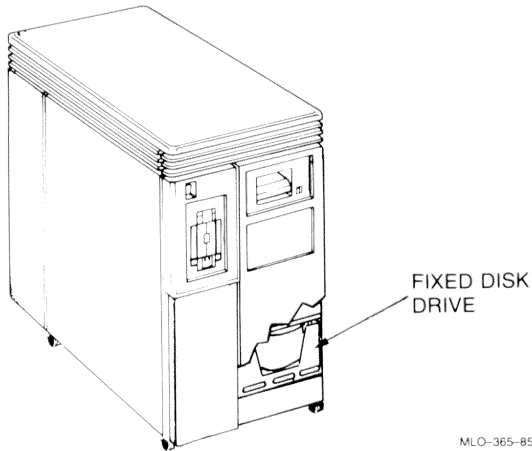

MLO-365-85

THE DEQNA COMMUNICATIONS MODULE

The Q22-bus-compatible DEQNA communications module interfaces between an Ethernet local area network (LAN) and a VAXstation. With a DEQNA interface, the VAXstation II system becomes a node on a DECnet network and can communicate with other computers that are also nodes on the network. The DEQNA option also enables a VAXstation II to be down-line loaded with a system image from a host computer on the network.

For more information about the DEQNA, see the following documents:

- *DEQNA User's Guide* (Order No. EK-DEQNA-UG)
- *MicroVAX Handbook* (Order No. EB-25156-47)

RX50 DUAL DISKETTE DRIVE

The RX50 dual diskette drive holds two 5.25-inch diskettes. Each diskette stores 400 kilobytes of information, which is roughly 150 typewritten pages. An **active drive indicator light** illuminates when a drive is in use.

The following points should be observed:

- Always close the drive door when using a diskette. The drive does not work with the door open.
- *Do not* open the drive doors when the **active drive indicator lights** are lit. Opening the doors could result in lost information.

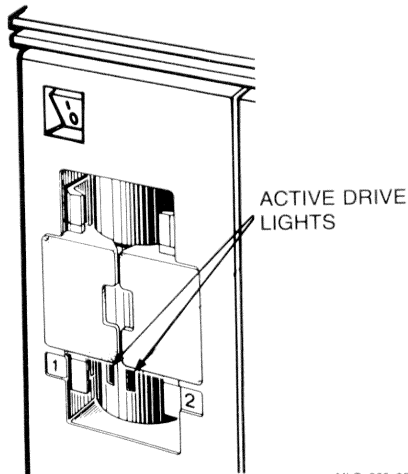

MLO-366-85

RX50 Diskettes

The information on RX50 diskettes is magnetically stored on one side of the diskette. The diskette must be correctly inserted in the disk drive. Stored information can be erased, and new information stored in its place. The diskette, permanently enclosed in a cover, rotates inside the cover. The soft fabric lining of the cover continuously cleans the diskette.

NOTE

Use only formatted RX50 diskettes, available from DIGITAL or DIGITAL's licensed distributors.

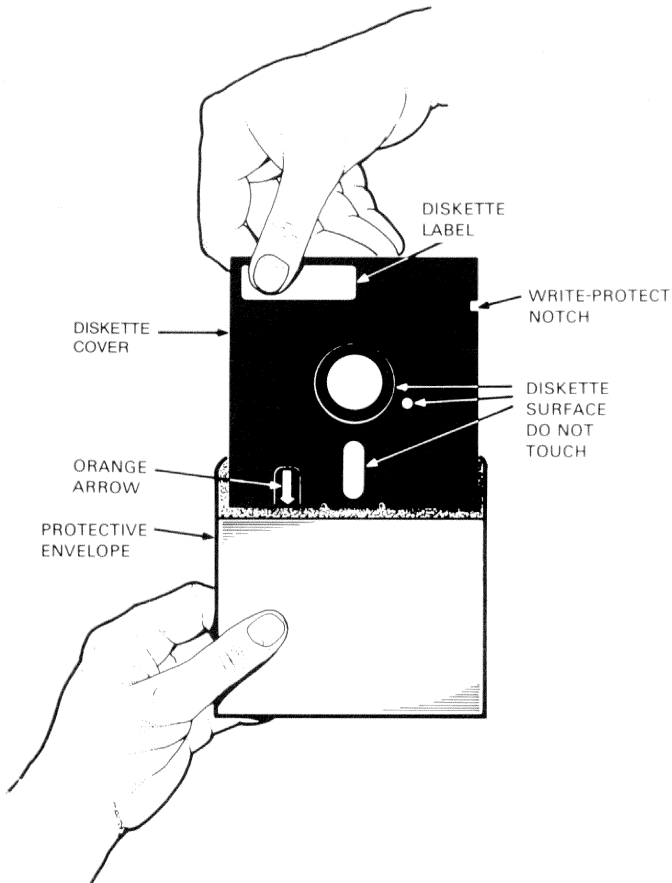

MLO-367-85

Figure 3-4: RX50 Diskette

Handling and Storing Diskettes

Incorrect handling and storing of diskettes can damage them (and/or the RX50 recording head) and cause loss of data. The following points should be observed:

- To keep out dust and dirt, put the diskette in its envelope when the diskette is not in use.
- *Do not* fold or bend the diskette cover.
- *Do not* touch the recording surface of the diskette. When out of its envelope, handle only the top (label area) of the diskette.
- Store the diskette vertically (with the label at the top) and loosely to prevent the cover from becoming warped.
- Write on a label before applying it to the diskette cover to avoid creasing the cover. If you need to change the label, use a felt-tipped pen.
- Store the diskette away from direct sunlight or heaters.
- Store the diskette away from strong magnetic fields and steel objects. Magnetic fields (produced by motors, transformers, and terminals) can erase data.

Protecting Diskettes from Accidental Overwriting

The RX50 diskette has a write-protect feature to prevent loss of data from accidental overwriting. To protect the data, cover the write-protect notch on the side of the cover with a self-adhesive foil tab supplied with your diskettes. Remove the tab when you want to add, change, or delete information on the diskette.

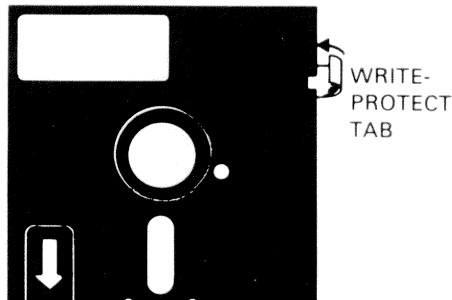

MLO-368-85

Inserting a Diskette

Keep the diskette drive door closed while the **active drive indicator light** is illuminated. Opening the door might damage the drive heads. Wait for the light to go off, which indicates activity has finished, or perform the procedures described in your software documentation to shut down the drive.

- A. Open the drive door by pressing on the door's outer edge.
- B. Align the orange arrow on the diskette cover with the orange stripe on the drive and insert the diskette. The write-protect notch is down in drive 1 and up in drive 2.
- C. After inserting the diskette, press the drive door closed. *Do not* use excessive force; the door should close easily.

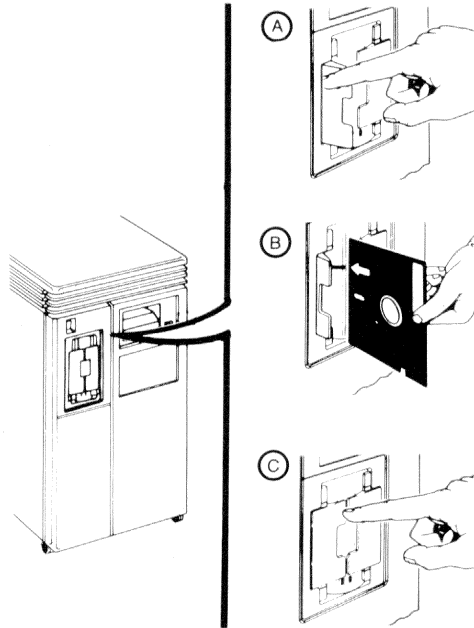

TK50 TAPE DRIVE

The TK50 tape drive holds one removable TK50 magnetic tape cartridge. Each tape cartridge holds 94.5 megabytes of information.

The information is magnetically stored on one side of a TK50 tape. Information can be erased, and new information stored in its place.

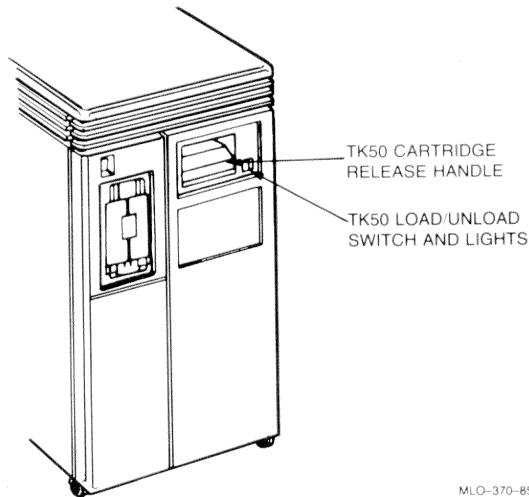

MLO-370-85

Figure 3-5: TK50 Tape Drive

Cartridge Release Handle

Pull up the **cartridge release handle** to insert a tape or to remove a tape after rewind and unload operations are completed. Moving the **cartridge release handle** down locks a tape in the operating position.

The Load/Unload Button

When the **Load/Unload** button is pressed in, a tape is loaded. When the **Load/Unload** button is pressed out, a tape is rewound. If a cartridge is inserted before power is turned on, loading takes up to 2 minutes. If a cartridge is loaded after power is turned on, loading takes 10-15 seconds.

The **Load/Unload** button lights and slowly blinks during tape loading or rewinding. The button also lights for 2 seconds during the power-up self test. The light turns off when the tape cartridge is ready for removal.

Table 3-2 describes the TK50 tape drive controls and indicators.

Table 3-2: TK50 Tape Drive Controls and Indicators

Control	Position	Function
Load/Unload	In	Loads the tape (10–15 seconds). If a tape is already in place when the power is turned on, rewinding and loading may take up to 2 minutes.
	Out	Rewinds and unloads the tape.
Green Light	Red Light	Condition
Off	Off	No power to the tape drive.
On	Off	Safe to lift cartridge release handle . Power is present.
Off	On	Do not lift the cartridge release handle . - Power-on self test is occurring. - Cartridge is inserted but handle is still up. - Tape is loading or unloading. - Tape is stopped.
On	On	Tape loaded successfully.
Flashing	On	Tape is in motion (except rewind). Read/write commands are being processed. Irregular, fast flashing means tape calibration is occurring.*
Flashing	Flashing	Tape is rewinding.

* If a tape is new, the system performs a calibration sequence that takes approximately 2 minutes.

(Continued on next page)

Table 3-2: TK50 Tape Drive Controls and Indicators (Cont.)

Flashing	Flashing rapidly	There is a fault. Press and release the Load/Unload button four times. If the problem persists, do not attempt to use the tape drive or to remove the tape cartridge. Call your service representative.
Handle	Position	Function
Cartridge Release Handle	Up	To insert a tape or to remove a tape after re-wind and unload operations are completed.
	Down	Locks tape in operating position.

Labeling a TK50 Tape Cartridge

To label a cartridge:

1. Write the identification on a label.
2. Insert the label in the slot on the front of a cartridge.

NOTE

Do not apply stick-on labels to the top, bottom, or sides of a cartridge.

NOTE

Do not write on a tape cartridge with a pen or pencil.

Handling and Storing Tape Cartridges

Follow these guidelines when handling and storing TK50 tape cartridges:

- *Do not* touch the exposed surface of the tape.
- *Do not* drop the tape cartridge. The impact from a fall can damage the tape cartridge.
- Allow new prerecorded tapes to stabilize at room temperature for 24 hours before using them.

- Write on the identification label before putting the label on the tape cartridge. Place the label only in the label slot on the front of the cartridge.
- Store tape cartridges in a dust-free environment.
- Keep tape cartridges away from direct sunlight, heaters, and other sources of heat. Store tape cartridges in an even temperature between 10 and 52 degrees Celsius.
- Keep tape cartridges away from magnets and equipment that generates magnetic fields (produced by motors, transformers, and terminals).
- Keep tapes away from x-ray equipment.

Protecting Tape Cartridges from Accidental Over-Writing

The TK50 tape cartridge has a write-protect feature to prevent loss of data by accidental overwriting. To prevent accidental overwriting on a tape cartridge, slide the write-protect switch to the left.

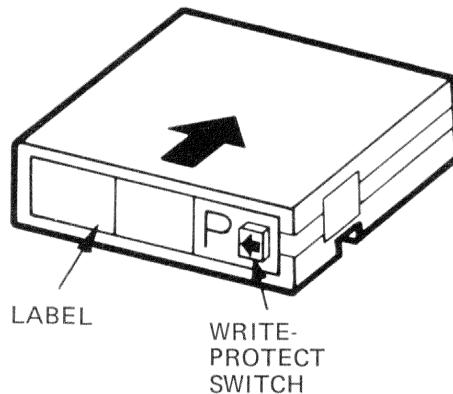

MLO-371-85

Inserting a TK50 Tape Cartridge

Make sure the power switch is set to 1 (on) and the **Load/Unload** button is out. The **Load/Unload** button illuminates red for approximately 2 seconds during the tape drive power-on self test.

The light extinguishes and the indicator light illuminates green, indicating that you can lift the **cartridge release handle**.

1. Lift up the **cartridge release handle**.
2. With the arrow on the tape cartridge facing up and pointing toward the drive, insert the cartridge into the drive.
 - The **Load/Unload** button illuminates red.
 - The indicator extinguishes.

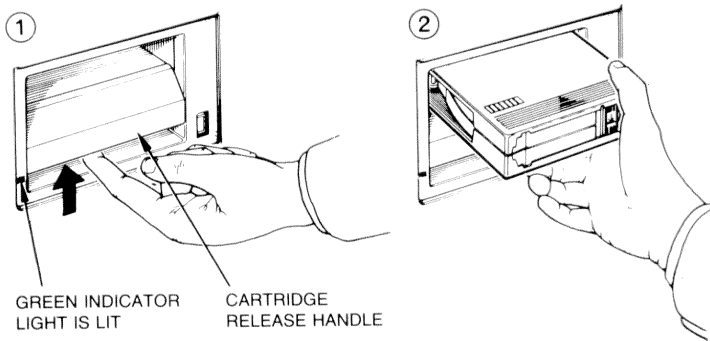

3. Push down the **cartridge release handle**. The **Load/Unload** button extinguishes.
 - The indicator illuminates green.
4. Push the **Load/Unload** button to the in position.
 - The **Load/Unload** button illuminates red.
 - The indicator is not lit.

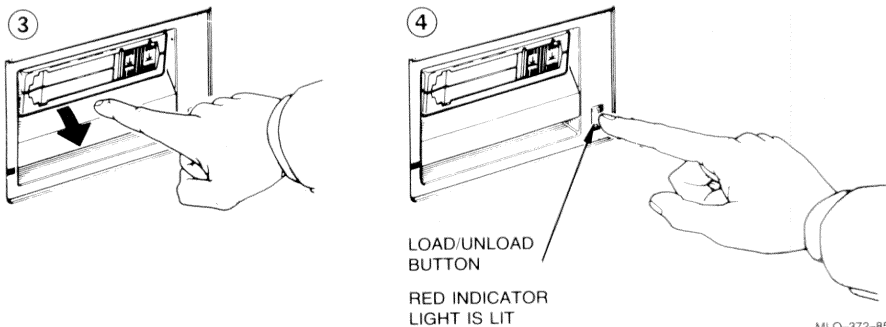

MLO-372-85

5. The tape loads in 10–15 seconds. Loading the tape means that a mechanism inside the tape picks up the tape and places it on a take-up reel inside the tape drive.

- The **Load/Unload** button illuminates red.
- When the indicator illuminates green, the tape is ready to use.

NOTE

If a tape is new, the system performs a calibration sequence that takes approximately 2 minutes. The indicator flashes green rapidly and irregularly during calibration.

CAUTION

Never lift the **cartridge release handle** when the **Load/Unload** button illuminates red. Make sure the indicator illuminates green.

CAUTION

If the **Load/Unload** button flashes red rapidly at any time, press the **Load/Unload** button four times. If the problem persists, do not attempt to use the tape drive or to remove the tape cartridge. Call your nearest service representative.

Rewinding and Unloading a Tape Cartridge

You must rewind and unload a tape before you can remove the tape cartridge from the tape drive.

1. Press the **Load/Unload** button to the out position to rewind and unload the tape. Rewinding a tape can also be done under software control. Refer to your software documentation for information.
 - The red and green lights flash slowly but not in unison as the tape rewinds to the beginning of the tape.
 - The **Load/Unload** button remains red, and the green indicator extinguishes as the tape unloads into the cartridge.
 - When the tape is completely rewound in the cartridge, the **Load/Unload** button extinguishes, and the green indicator illuminates.

2. Lift up the **cartridge release handle**.
3. Remove the tape cartridge and store it in a safe place.
4. Push down the **cartridge release handle**. The indicator remains green, showing that there is power to the drive.

NOTE

Rewinding a tape can also be done under software control. Refer to your software documentation for information.

MAKING BACK-UP COPIES

A back-up copy is a copy of files stored on the VAXstation II fixed disk, diskette, or tape. Making back-up copies of files ensures a copy for you in case information is accidentally lost. As a general rule:

- Make back-up copies of diskettes or magnetic tape.
- Make a daily back-up copy of all information you create or change that day.
- Make a weekly back-up copy of all information stored on your fixed disk drive.
- Store back-up copies in a safe place.

Make back-up copies of system software files as described in the system software documentation. A procedure for making a back-up copy of the *MicroVAX Maintenance System* software is contained in the *VAXstation II System Technical Manual*.

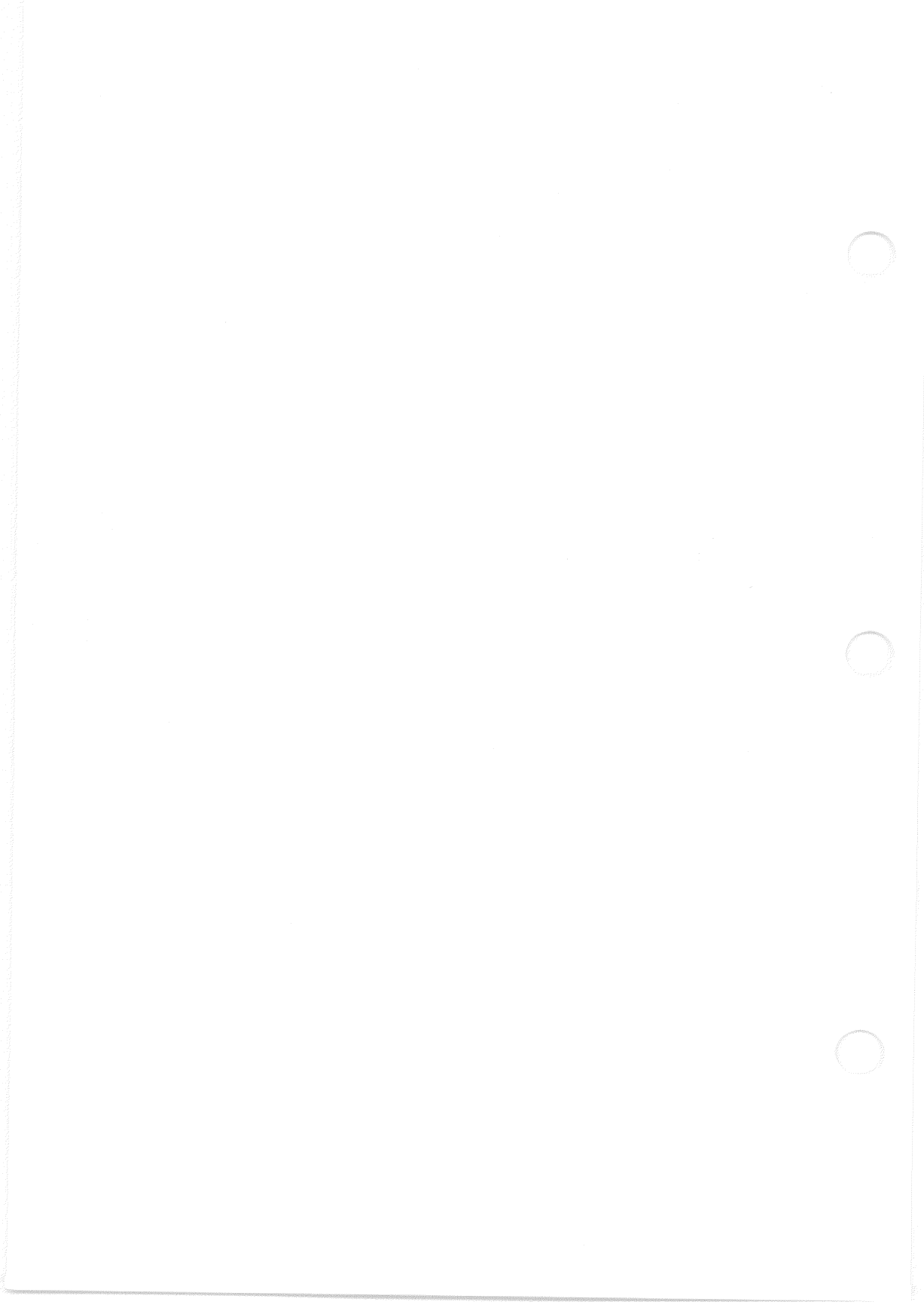

This chapter describes the following hardware options for the VAXstation II:

- Printers (LA50, LA210, and LN03-AA)
- Tablet (VSXXX-AB)
- Memory modules (M7607-AA, M7608-AA, and M7608-BA)
- Free-standing disk drive subsystem (RD52-D and RD53-D)
- Asynchronous Multiplexer (DZQ11)
- Synchronous Line Controller (DMV11-AA/AB/AC)

This chapter describes each option and directs you to installation instructions. You may install a printer and the tablet yourself. Call your service representative to install a memory module, the free-standing disk drive subsystem, the multiplexer interface module, and an asynchronous or a synchronous line controller.

CAUTION

If you attempt to install a memory module, the free-standing disk drive subsystem, the multiplexer interface module, the asynchronous or the synchronous line controller yourself, you may damage the system.

To order an option after initial installation, contact your sales representative.

For more information on these options, refer to the documents listed at the end of each section.

THE PRINTERS

The printers that can be used with the VAXstation II are the LA50, the LA210, and the LN03-AA. Each of the following sections describes one of the printers. The final section explains how to connect a printer to a VAXstation II.

The LA50

The LA50 is a desktop dot-matrix unit. You can display bit-map or character cell graphics with the unit.

The LA50 prints in draft speed (100 characters/second) and memo speed (50 characters/second). The printer offers one font and six character widths. Ten national character sets are available. You may use office stationery or fanfold paper.

The LA50 weighs 18.7 pounds (8.5 kilograms).

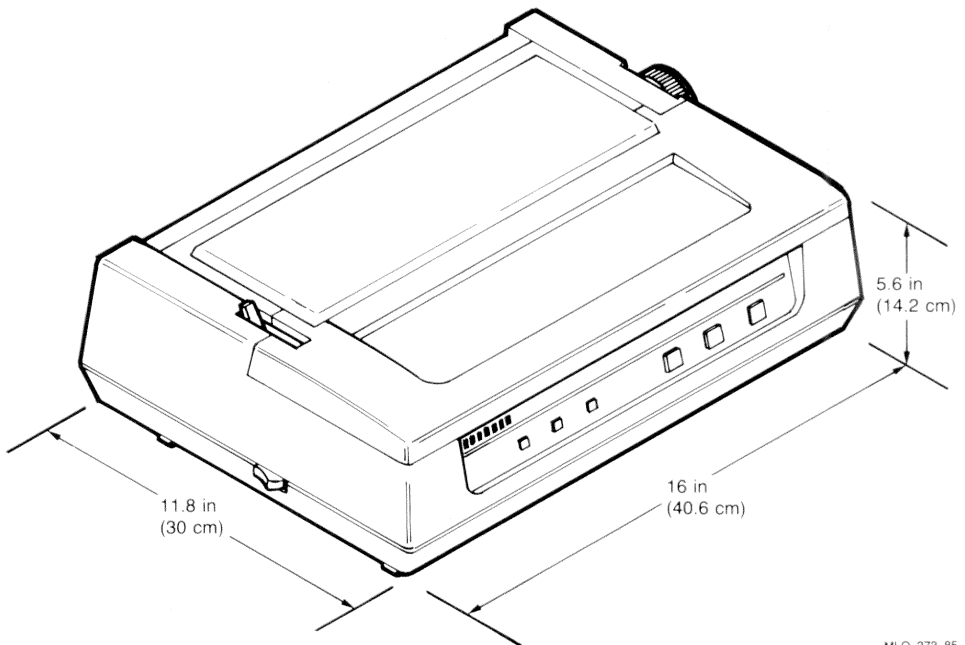

MLO-373-85

For more information about the LA50 printer, see the following documents:

- *Installing and Using the LA50 Printer* (Order No. EK-0LA50-UG)
- *LA50 Printer Programmer Reference Manual* (Order No. EK-0LA50-RM-001)

The LA210

The LA210 is a dot-matrix desktop printer.

The device allows different print speeds. You can produce high-speed drafts (240 characters/second) or near letter-quality correspondence (40 characters/second). An option allows you to print at memo speed (80 characters/second). The LA210 also prints bit-map graphics.

The printer can print in USASCII, 10 national languages in Courier 10, and VT100 line-drawing characters. Other features include three optional typefaces: Gothic, Orator, and Italic. Over 30 optional character sets, including symbols and technical characters, can be added by convenient plug-in font cartridges. You may select up to eight character widths.

The LA210 prints on single-sheet and fanfold paper and handles forms with up to four parts. The printer's carriage accommodates paper ranging in width from 3.5 inches (8.9 centimeters) to 14.9 inches (37.8 centimeters).

The printer weighs 25 pounds (11.3 kilograms).

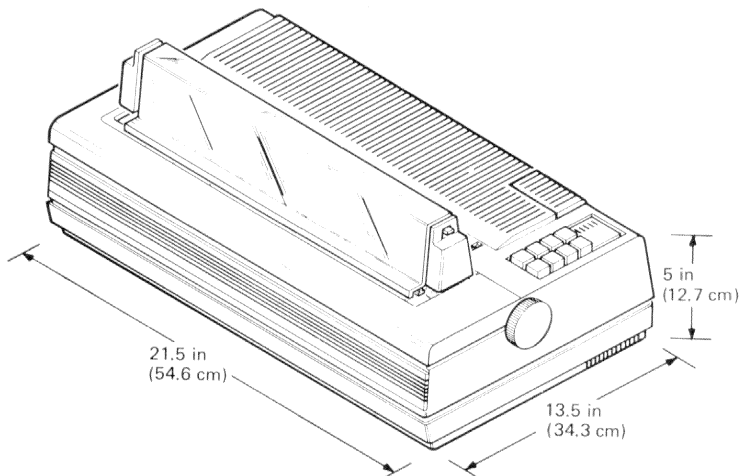

For more information about the LA210 printer, see the following documents:

- *Installing the LA210 Letterprinter*, EK-LA210-IN-001
- *LA210 Letterprinter User Guide*, EK-LA210-UG-001
- *LA210 Letterprinter Programmer Reference Manual*, EK-LA210-RM-001
- *LA210 Letterprinter Operator and Programmer Reference Guide*, EK-LA210-RC-001
- *LA210 Letterprinter Emulation Modes Reference Guide*, EK-LA210-RG-001

The LN03-AA

The LN03 laser printer provides speed, quality, and flexibility in a desktop printer. Because the laser printing process is nonimpact, the LN03 is quieter than impact printers.

The LN03 produces letter-quality text at eight pages/minute (333 characters/second for a 2500-character page). The printer can also display graphics.

The LN03 offers 16 fonts, including Courier, Elite, and the VT100 Line Drawing Set. ASCII multinational technical character sets are also offered. Twelve national language character sets may be used.

The printer comes with three character sets. If you want to mix type styles and point sizes, the LN03 can print up to 24 fonts/page. To expand memory or add additional fonts, you can purchase more programmable RAM or precoded ROM cartridges from DIGITAL.

The LN03 uses only cut sheet paper. A paper cassette holds 250 sheets of paper. The printer automatically collates output for you. The LN03 can also handle preprinted single-part forms, transparencies, and labels. The LN03 can print in either landscape (horizontal) or portrait (vertical) mode.

CAUTION

When the Halt Enable/Disable switch is in the up (enable) position, powering on and off the LN03 that is connected to an operating VAXstation II can halt the system and cause the irretrievable loss of data.

The LN03 weighs 66 pounds (28 kilograms).

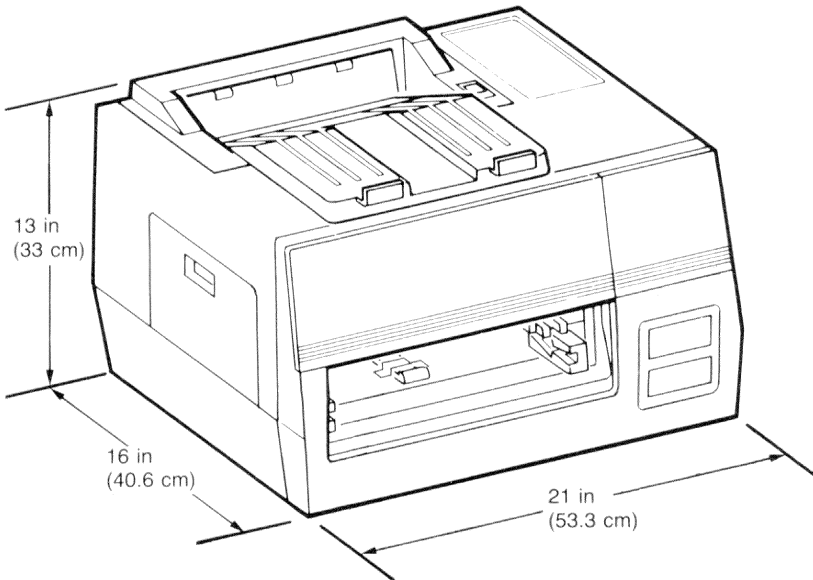

MLO-375-85

For more information about the LN03 printer, see the following documents:

- *Installing and Using the LN03*, EK-0LN03-UG-001
- *LN03 Programmer Reference Manual*, EK-0LN03-RM-001
- *LN03 Maintenance Kit Guide*, EK-LN03U-MG-001
- *LN03 Toner Kit Guide*, EK-0LN03-MG-001

Printer Connection to the VAXstation II

The BCC08 cable is required to connect a printer to the VAXstation II. You must order this cable in addition to the printer. To connect a printer to a VAXstation II:

1. Make sure that the power switches for the printer and the VAXstation II are off.
2. Check that the printer and the system unit are set to the same baud rate (4800).
3. Attach the smaller end of the communication cable to the back of the printer.
4. Open the back door of the system unit.
5. Attach the free end of the communication cable to the CPU distribution panel of your VAXstation II (see Figure 4-1).

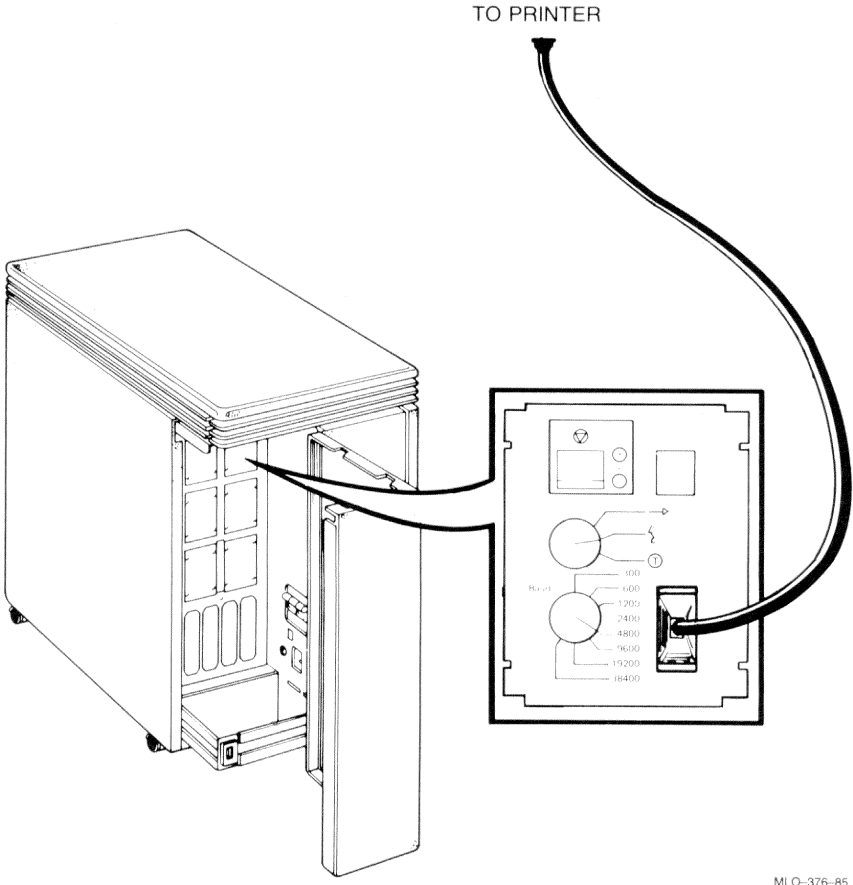

MLO-376-85

Figure 4-1: Printer Connection to the VAXstation II

6. Close the back door of the system unit.

NOTE

If you are connecting the LA210 printer to the VAXstation II, make sure that XOFF and wrap are enabled. This may require toggling switches on the printer as explained in the LA210 documentation.

THE TABLET

The tablet system consists of a digitizing tablet, a 4-button puck, a 2-button stylus, and a 5-foot power/signal cable. The tablet may be used as a pointing device instead of the mouse for menu selection, graphics entry, and cursor control. Chapter 2 explains how to connect the tablet to the VAXstation II. The digitizing tablet is an input device that sends X-Y coordinates to the VAXstation II to accurately indicate the position of a stylus or puck on the tablet's surface. The tablet has a resolution of 0.005 inches (200 counts/inch).

The tablet communicates with the VAXstation II through an asynchronous, full-duplex serial interface at 4800 baud (+/- 2%).

The active area of the tablet is 11 inches x 11 inches (279 x 279 millimeters). The tablet weighs 7 pounds (3.2 kilograms).

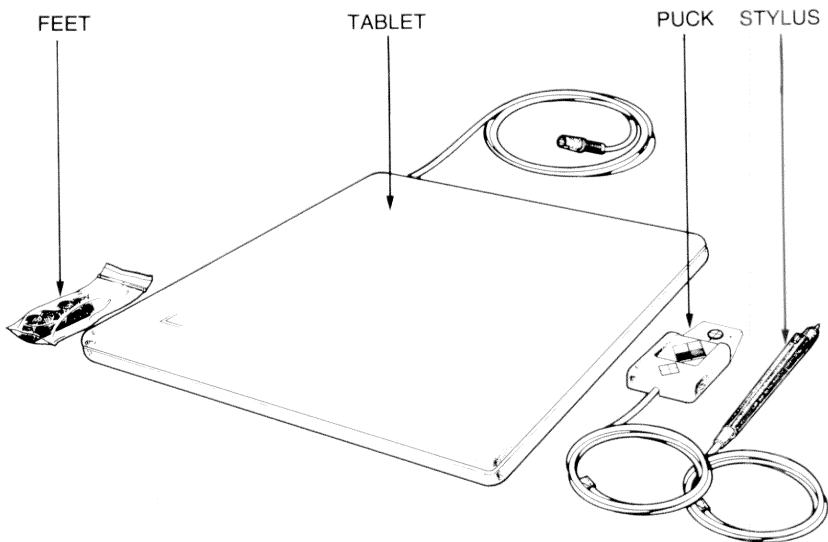

MLO-564-85

THE MEMORY MODULES

The following MS630 memory expansion modules are available with 1, 2, or 4 megabytes of memory:

Option	Description
M7607-AA	1 Mb Memory Expansion Module, dual-height module with 256K RAMs.
M7608-AA	2 Mb Memory Expansion Module, quad-height module with 256K RAMs (half populated M7608-BA).
M7608-BA	4 Mb Memory Expansion Module, quad-height module with 256K RAMs.

To add a memory module to your VAXstation II after the initial system installation, contact your sales representative. If you experience problems with the memory module, call your service representative.

For additional information about the memory modules, see:

- *KA630-A CPU Module User's Guide (EJ-KA630-UG)*

THE FREE-STANDING DISK SUBSYSTEM

The free-standing disk subsystem is similar to the fixed disk mounted inside the VAXstation II system unit. The free-standing disk subsystem provides external add-on storage for the VAXstation II. The RD52-D has an unformatted capacity of 42 megabytes. The RD53-D has an unformatted capacity of 85 megabytes.

Each subsystem has a chassis that holds the fixed disk drive assembly, a power supply assembly, a dc cooling fan assembly, a printed circuit board for external cable signal distribution, a front bezel, and a rear bezel.

The subsystem is mounted in a desktop configuration and used at either 120 Volts ac or 240 Volts ac. The chassis comes with a cover and front and rear bezels.

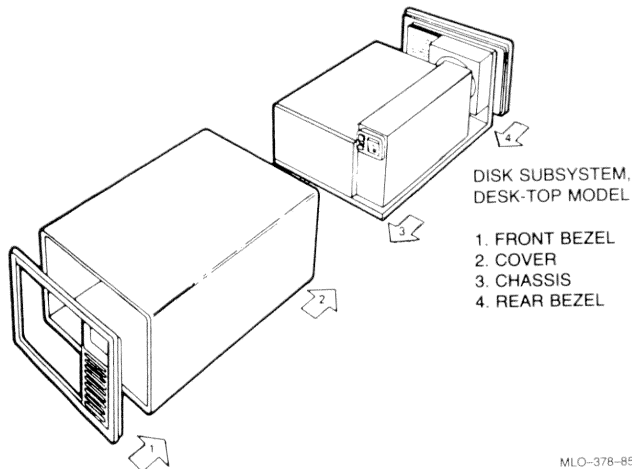

MLO-378-85

To add a disk subsystem to your VAXstation II after the initial system installation, contact your sales representative.

After ordering the disk subsystem, you receive two boxes. One box contains the subsystem, and the other contains a RQDX2 module and a cable. Your service representative requires them to install the disk subsystem.

If you experience problems with your disk subsystem, call your service representative.

THE DZQ11 ASYNCHRONOUS MULTIPLEXER

The DZQ11 is an asynchronous multiplexer that connects the Q22-bus with up to four asynchronous serial data communications channels.

The DZQ11 is a dual-height module that is used to connect hard-copy and video terminals, with or without modems, to a system. With a VAXstation II, the DZQ11 can also be used as an asynchronous DECnet link. The DZQ11 allows dial-up (auto-answer) operations with modems capable of full-duplex operation, such as DIGITAL's models DF01, DF02, and DF03.

The DZQ11 provides flexible control of parameters, such as baud rate (50 to 9600), character length, number of stop bits for each line, odd or even parity for each line, and transmitter-receiver interrupts. Additional features include limited data set control, break generation and detection, and silo buffering of received data.

To add a DZQ11 to your VAXstation II after the initial system installation, contact your sales representative.

For more information about the DZQ11, see:

- *DZQ11 Asynchronous Multiplexer User's Guide* (Order No. EK-DZQ11-UG-001)

THE DMV11 SYNCHRONOUS LINE CONTROLLER

The DMV11 Intelligent Communications Synchronous Line Controller is a device that provides efficient high-speed synchronous communications for distributed networks.

Point-to-point configurations are practical when terminals have a high message rate. However, the message rate of the terminals is usually very low,

even though the bit rate may be quite high. In those cases, sharing a transmission line can significantly reduce the cost and improve the efficiency of a communications network.

The DMV11 is a high-performance line controller that operates at speeds up to 56 kilobytes/second.

The three types of the DMV11 synchronous line controller are:

1. DMV11-AA

- M8053-MA microcontroller/line unit (a quad-height module with multi-point microcode)
- H3254 (V.35 or integral modem) module test connector
- H3255 (RS-423-A/232-C) module test connector
- BC55H cable
- H325 and H3251 cable turnaround test connector

2. DMV11-AB

- M8053-MA microcontroller/line unit (a quad-height module with multi-point microcode)
- H3254 (V.35 or integral modem) module test connector
- H3255 (RS-423-A/232-C) module test connector
- BC05Z-25 cable
- H3250 cable turnaround test connector

3. DMV11-AC

- M8064-MA microcontroller/line unit (a quad-height module with multi-point microcode)
- H3254 (V.35 or integral modem) module test connector
- H3255 (RS-423-A/232-C) module test connector
- BC55F cable

Installing Options

- H3247 and H3245 terminators

For more information on the DMV11 synchronous controller, see:

- *DMV11 Synchronous Controller User's Guide* (Order No. EK-DMV11-UG).

Troubleshooting Procedure **5**

This chapter provides troubleshooting information that enables you to repair minor problems. This section contains four parts:

1. Basic troubleshooting – This section provides a checklist of potential problems and solutions.
2. Power-up message – This section explains the indications that appear when the system is turned on.
3. Maintenance system – This section describes the maintenance tests, VAXstation II system utilities, and when to use those utilities. The part discusses the **Main Menu** and describes maintenance options.
4. Monitor troubleshooting – This section lists solutions to potential problems.

BASIC TROUBLESHOOTING

The corrective actions listed in Table 5-1 are for minor problems. More serious problems require maintenance procedures described in the *VAXstation II System Technical Manual*. Those procedures should be performed by service personnel.

Once you have isolated the problem, contact your support person for help. If that person is unable to correct the problem, call the DIGITAL help line.

Table 5-1: Basic Troubleshooting Procedures

Problem	Possible Cause	Corrective Action
No response when the power switch is turned on (switch is not lit).	System is not plugged in.	Plug in the system.
	There is no power at the wall outlet.	Use a different wall outlet.
	System circuit breaker is tripped.	Set the power switch to off. Reset the circuit breaker by pushing it down and then lifting it up (see Figure 5-1). Set the power switch to on. If the circuit breaker trips again, refer the problem to service personnel.
	Power cable is incorrectly installed.	Set the power switch to off. Check that the cable is fully seated into the socket in the back of the system.

(Continued on next page)

Table 5-1: Basic Troubleshooting Procedures (Cont.)

Problem	Possible Cause	Corrective Action
---------	----------------	-------------------

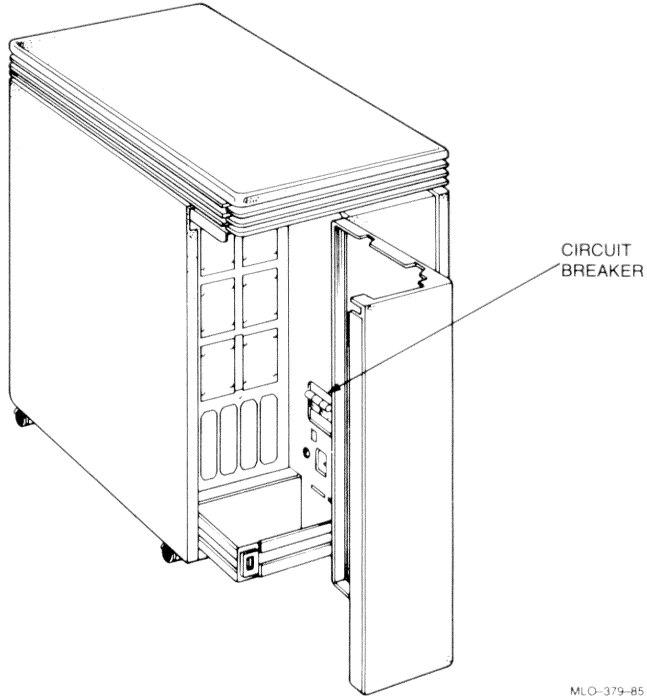

MLO-379-85

Figure 5-1: System Circuit Breaker

Power is on (1/0 switch is lit), but the display on the monitor does not appear.	Monitor is off.	Turn on the monitor.
	Monitor cable is not installed correctly.	Make sure that the cable is installed properly at both ends.

(Continued on next page)

Table 5-1: Basic Troubleshooting Procedures (Cont.)

Problem	Possible Cause	Corrective Action
Instead of automatically booting, system power on results in >>> being displayed on the monitor.	The Halt Enable/Disable switch is set to the Enable position.	The system is in console mode. To exit console mode, set the Halt Enable/Disable switch to the Disable (down) position and then restart the system.
System does not boot from the fixed disk drive.	Ready button is in.	Press and release the Ready button.
	System software is not on the disk.	Load (install) the system software on the fixed disk, using the system software installation instructions supplied with the software.
System does not boot from the diskette drive.	Diskette is not in the diskette drive.	Insert a diskette containing bootable system software in diskette drive 1.
	Diskette drive door is not closed.	Close the diskette drive door.
	Diskette is in the drive upside down.	Check that the orange stripe on the diskette matches the stripe on the drive.
	Diskette is not bootable.	Use a diskette containing bootable system software.

(Continued on next page)

Table 5-1: Basic Troubleshooting Procedures (Cont.)

Problem	Possible Cause	Corrective Action
	Diskette is worn or damaged.	Try another diskette.
Fixed disk read error message is displayed.	Ready button is in.	Press and release the Ready button.
Fixed disk write error message is displayed.	Disk is write-protected.	Press and release the Write-Protect button.
Diskette read error message is displayed.	Diskette is not in the diskette drive.	Insert a diskette in the diskette drive.
	Diskette drive door is not closed.	Close the diskette drive door.
	Diskette is upside down in the diskette drive.	Check that the orange stripe on the diskette matches the stripe on the drive.
	Diskette is not formatted.	Use a preformatted RX50 diskette.
	Diskette is worn or damaged.	Try another diskette.
Diskette write error message is displayed.	Diskette is not in the diskette drive.	Insert a diskette in the drive.
	Diskette drive door is not closed.	Close the diskette drive door.
	Diskette is in the drive upside down.	Check that the orange stripe on the diskette matches the stripe on the drive.
	Diskette is not formatted.	Use a preformatted RX50 diskette.

(Continued on next page)

Table 5-1: Basic Troubleshooting Procedures (Cont.)

Problem	Possible Cause	Corrective Action
System does not boot from the TK50 tape drive.	Diskette is worn or damaged.	Try another diskette.
	Diskette may be write-protected.	Remove foil tab covering write-protect notch.
	Fixed Drive is on line. (Ready button is lit.)	Push the Ready button.
System halts unexpectedly during normal operation.	Load/Unload button is out.	Push the Load/Unload button.
	The Halt button was pressed.	Power on system again. Set Halt Enable/Disable switch to disable position to prevent reoccurrences.
TK50 passes power-on test but does not work.	Tape is not in the drive or it is not loaded.	Insert the tape and press the Load/Unload button.
TK50 red indicator light flashes rapidly.	There is a possible problem with the tape drive.	Press the Load/Unload button four times. If the problem persists, do not attempt to use the tape drive or to remove the tape cartridge. Call your service representative.

(Continued on next page)

Table 5-1: Basic Troubleshooting Procedures (Cont.)

Problem	Possible Cause	Corrective Action
Tape cartridge re-lease handle does not lift.	The power-on test is still in process.	Wait for the red light to go out and try again. If the problem persists, it may be mechanical. Call your service representative.
Tape cartridge re-lease handle does not lock.	Tape is not inserted properly.	Reinsert the tape cartridge. If the problem persists, call your service representative.
Tape does not unload.	Load/Unload switch is in load position.	Make sure the Load/Unload switch is in the unload position. Wait for the light to go out before trying to remove the tape.
Monitor displays “?54 RETRY” when system diagnostics are running.	You have failed to respond to a system prompt.	Begin the testing procedure again.

POWER-UP MESSAGES

During the power-up sequence, the VAXstation II executes built-in diagnostic and bootstrap routines that provide useful maintenance information. The information is displayed in single letters and numbers on both the LED display, located on the CPU distribution panel on the back of the VAXstation II system unit, and on the monitor. Normally, the display progresses from F to 0.

If the display stops in the range of F to 3, a hardware error may exist in the VAXstation II system; refer to the *VAXstation II System Technical Manual*.

If the display stops on 2, check the “system does not boot from ...” problem indications listed in Table 5-1.

If the display stops on 1, the bootstrap device may not contain bootable system software. Complete the system software installation as directed in the documentation supplied with your system software.

MAINTENANCE SYSTEM

The *MicroVAX Maintenance System* software provides user tests that isolate and identify faults in the system. You can test the system in response to an error message or test your system periodically. Always test the system (and record the results) before calling DIGITAL to report a problem.

In addition, the *VAXstation II Maintenance Software* displays provide a list of system utilities and system devices.

The *VAXstation II Maintenance Software* is stored on RX50 diskettes or on a TK50 cartridge. To run the *MicroVAX Maintenance System* programs, use the monitor and keyboard to input commands and to call VAXstation II system displays.

The Maintenance System Main Menu

The **Maintenance System Main Menu** lists the testing options. Figure 5-2 shows the **Main Menu**. You can obtain the **Main Menu** display as directed in Chapter 2.

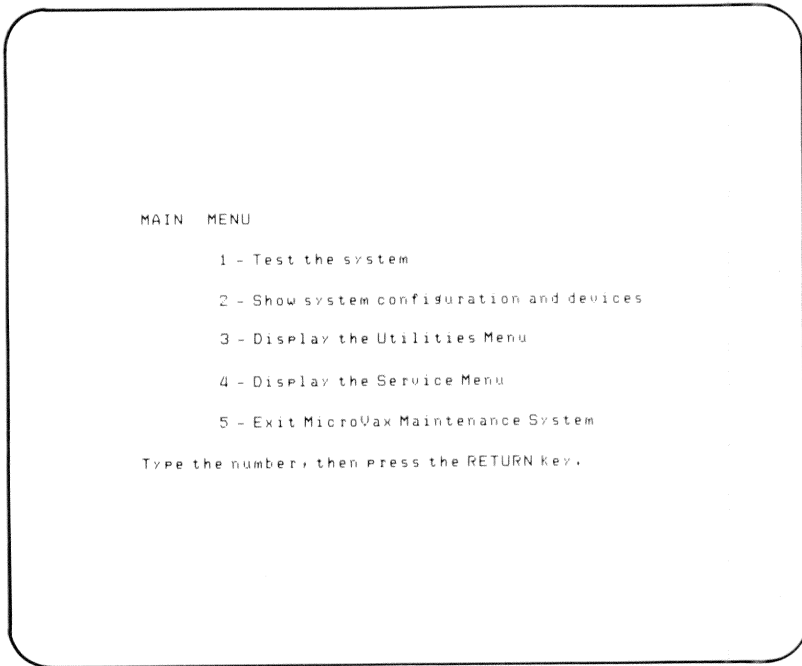

MLO-380-85

Figure 5-2: Maintenance System Main Menu

The *Maintenance System* option displays are described as numbered in the **Main Menu** in Figure 5-2.

1. This option tests the devices supplied by DIGITAL for a VAXstation II system. You can test these devices as described in Chapter 2.

2. This option displays a list of the devices supplied by DIGITAL for a VAXstation II system. Since you may not have the configuration illustrated in Figure 5-3, your screen may look different from the example.

```

Type the number; then Press the RETURN key. >2
SYSTEM CONFIGURATION AND DEVICES
SYSTEM CONFIGURATION
CPUA ... MicroVAX CPU
      KAG30-AA 1MB, FPU M00 H00
MEMA ... MicroVAX memory system
      2 megabytes, 4096 Pages,
      KAG30 ... CPU module, 1MB on-board memory,
      MSG30-AA ... Dual height memory module, 1MB.
RQDXA ... Winchester/diskette controller.
      Revisions =10 and 6
      ... Cannot identify drive, Offline.
      RX50 ... Removable
      RX50 ... Removable
DEQNA ... Ethernet controller.
      08-00-2B-02-17-D3
VCB01 ... Graphics Terminal Subsystem

Press the RETURN key to return to the previous menu. >
```

MLO-381-85

Figure 5-3: An Example of a System Configuration and Devices Screen

3. This option displays the system utilities. Only service personnel should use this menu. (See the *VAXstation II System Technical Manual* for additional information.)
4. This option displays the Field Service diagnostics. Only service personnel should use them. (See the *VAXstation II System Technical Manual* for additional information.)
5. This option allows you to exit from the Maintenance System.

MONITOR TROUBLESHOOTING

If you have a problem with the VR260, check Table 5-3 before calling for service. You may be able to correct some problems. If you still need help, call your service representative.

NOTE

If you return the monitor to DIGITAL, pack the monitor in its original carton.

Table 5-2: Monitor Troubleshooting Procedures

Problem	Possible Solution
The monitor does not power-up when you turn on the power switch.	<p>Check that the monitor is connected correctly to an active power source.</p> <p>Check that the voltage select switch is set correctly. See Chapter 2.</p> <p>Check the monitor fuse. See Chapter 2 and the following section.</p>
The green power indicator is on but the screen is dark.	<p>Check the monitor contrast and brightness controls.</p> <p>Check the host system.</p>
The monitor displays a raster but does not produce a test pattern from the host system.	<p>Check that the video cable connection between the monitor and the host system is secure.</p> <p>Check that the host system is powered on.</p>
The screen display is out of shape or is unstable.	<p>Check that the video cable connection between the monitor and the host system is secure.</p>

Replacing the Fuse

You may have to replace the monitor fuse.

Troubleshooting Procedure

For 120-volt operation, the monitor uses a 1-Ampere, 250-volt Slow Blow fuse (part number: 90-07212-003).

For 240-volt operation, the monitor uses a .5-Ampere, 250-volt Slow Blow fuse (part number: 12-19283-19).

Replace the fuse as follows:

1. Turn off the power and disconnect the power cord.
2. Remove the video cable assembly.
3. Push and turn the fuse carrier, using a small coin or screwdriver.
4. Pull out the fuse carrier and replace the fuse.
5. Replace the video cable assembly.

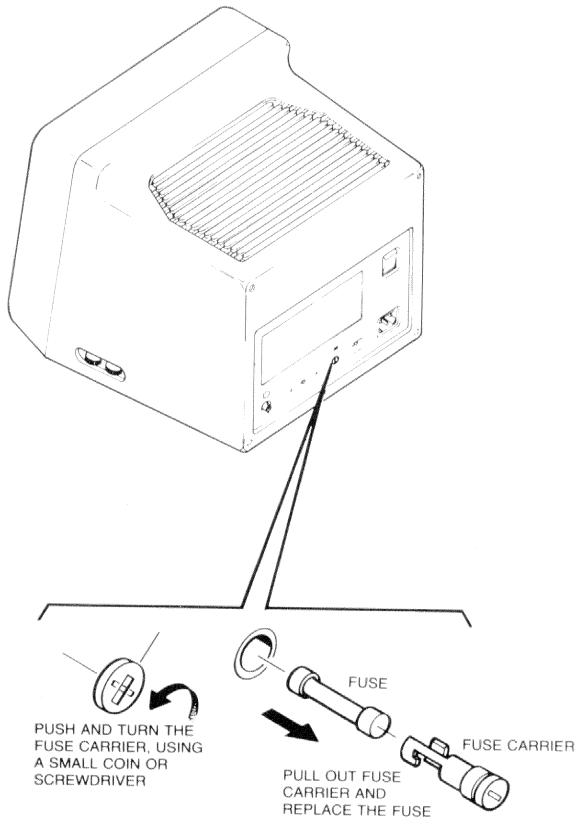

MLO-382-85

If you are unable to correct a problem with your VAXstation II, contact your service representative. This chapter describes how to call DIGITAL for help and the available services.

HOW TO CALL FOR DIGITAL SERVICE

Before calling your service representative:

1. Check the problem-solving suggestions listed in Chapter 5. Often you can solve a problem yourself.
2. Write down the serial and model numbers of your VAXstation II. These numbers are located on the rear panel of the system unit.
3. Summarize the problem. Make a note of what you were doing when the system failed. Note if any indicators turned on or off or if you heard any new sounds just before or after the system failed.

When you call:

- Stay near the VAXstation II.
- Have all your materials available. The service technician may ask you to recreate the problem.

Call 1-800-DEC-8000, and a DIGITAL representative will help you.

If you have to return the VAXstation II to DIGITAL for service, you must repack the system in the same containers it was shipped in.

AVAILABLE DIGITAL SERVICES

Your DIGITAL hardware comes with a warranty that gives you access to DIGITAL's best resources, including technical expertise, spare parts inventories, and worldwide service.

After warranty, DIGITAL's support continues through on-site and off-site services for as long as you own your DIGITAL hardware. These services help you get the maximum performance from your system.

DIGITAL's on-site services provide fast response time and full support, including the cost of all parts and labor.

DECservice

DECservice is DIGITAL's most comprehensive on-site service alternative. DECservice provides committed response times, including a 4-hour service response if your system is within 100 miles of a DIGITAL service location. DECservice also provides continuous repairs until the problem is solved, a program of preventive maintenance, installation of the latest engineering changes, and automatic service escalation for complex problems.

DECservice lets you choose when you need support, up to 24 hours a day, 7 days a week.

Basic Service

Basic service is available during standard business hours, 8 a.m. to 5 p.m., Monday through Friday.

Per Call Service

If your system does not require comprehensive support, you can use one of DIGITAL's per call service alternatives. Per call service is available on-site and off-site on a noncontractual basis. Service is available Monday through Friday during standard business hours, from 8:00 a.m. to 5:00 p.m.

For on-site per call service, you pay for the time and materials required for each service call. Off-site per call service is available through mail-in board replacements and carry-in system repairs.

Carry-In Service

This is DIGITAL's low-cost alternative to on-site support. You can carry your VAXstation II into any of the 150 DIGITAL service centers throughout the United States and pick up the repaired equipment within two days. Or, if you perform your own maintenance, you can carry in your faulty module, and DIGITAL will make an over-the-counter exchange.

Carry-in service is available through a 1-year, fixed-cost agreement or on a per-call basis for which there is flat rate charges for labor, plus the cost of all parts used in the repair. All carry-in service and parts come with a 90-day warranty.

DECmailer Service

DECmailer is a return-to-factory replacement service for DIGITAL's customers who maintain their equipment to the module or subassembly levels. DECmailer service provides a 5-day turnaround, free return shipping, a 90-day warranty, 24-hour emergency service, monthly billing, and quarterly activity reports.

Spare Parts

DIGITAL's Customer Spares organization provides support in spare inventory, maintenance test equipment, documentation, and emergency spare parts.

Appendix VAXstation II System Specifications

Table A-1: System Electrical Requirements

Input	Specifications *	
	120 Vac	220 Vac
Voltage tolerance	88–128 V	176–256 V
Power source phasing	single	single
Frequency	60 Hz	50 Hz
Line frequency tolerance	47–63 Hz	47–63 Hz
Running current (typical)	8.8 A	4.4 A
Running current (maximum)	12.0 A	6.0 A
Power consumption (maximum) (switchable for input voltage)	690 W	690 W

* These requirements depend on the line voltage setting that you select.

Table A-2: System Environmental Requirements

	Operating	Nonoperating
Maximum altitude	2400 m	12000 m
Temperature range*	15–32 deg. C	-40–60 deg. C
Temperature change rate	1 deg. C/hour	—
Relative humidity	20%–80%	10%–95%

* Reduce the maximum temperature specification by 1.8 degrees Celsius for each 1000 meter increase in altitude.

NOTE

Your service contract may require limits for temperature and humidity that override the limits listed above.

Table A-3: Monitor Specifications**Physical**

Height	15.36 in (390 mm)
Width	17.93 in (455 mm)
Depth	15.42 in (395 mm)
Weight	Approximately 40 lb (18 kg)

Video Format

Composite video
Black negative
70 MHz bandwidth

Timing

Vertical rate	60 Hz
Horizontal rate	54 KHz

Power

Power supply type	Transistor, switch type ac to dc converter
AC input	Switch selected

(Continued on next page)

Table A-3: Monitor Specifications (Cont.)

115 V nominal (110/115/120)	Single-phase, 3-wire 8–132 V rms, 47–63 Hz line frequency
230 V nominal	Single-phase, 3-wire 185–264 V rms, 47–63 Hz line frequency
Power consumption	Approximately 65 watts
Fuse	1.0 A 100–120 Vac DIGITAL part no. 90–07212–00
	0.5 A 220–240 Vac DIGITAL part no. 12–19283–19
Temperature	
	10–40 deg. C (50–104 deg. F)
Humidity	
	10%–90% relative humidity with a maximum wet bulb of 28 deg. C. and a minimum dew point of 2 deg. C.

Table A-4: Mouse Specifications**Physical**

Construction	Molded plastic
Finish	Vapor hone texture
Color	Light grey
Cable	12 ft (3.66 m) in length ten conductors, shielded

(Continued on next page)

Table A-4: Mouse Specifications (Cont.)

Connector	15-pin male "D" subminiature connector with 4-40 jack screws; connector with metal "D" shield
Switches	Three tactile feel type switches
Electrical	
Power	+5 V dc +/- 10% at less than 110 mA
Environmental	
Temperature Operating	10-40 deg. C
Nonoperating	-40-+66 deg. C
Humidity	
Operating	10%-90% relative humidity with a maximum wet bulb temperature of 28 deg. C and a minimum dew point of 2 deg. C
Nonoperating	5%-95% relative humidity with a maximum wet bulb temperature of 46 deg. C
Performance	
Countable edges	Mouse will produce up to 200 countable edges/in +/- 3% at up to 10 in/second in any direction
Resolution	200 counts/in
Accuracy	+/- 3% at up to 10 in/second

Table A-5: Tablet Specifications**Physical**

Construction	Molded, high-impact plastic
Finish	Fine matte finish to minimize glare and fingerprints
Color	Light grey
Power/Signal cable	5-foot cable wired to tablet, terminated in a 7-pin Micro-Din connector
Height	0.80 in (20 mm)
Width	16.2 in (412 mm)
Length	16.0 in (406 mm)
Weight	7 lb (3.2 kg)

Performance

Resolution	200 counts/in (20 counts/mm)
Active area	11 in x 11 in (279 mm x 279 mm)
Proximity (Nominal)	0.5 in (12.7 mm) cursor 0.25 in (6.3 mm) stylus
Interfaces	Serial, asynchronous, full-duplex, with RS232C signal levels
Sampling rate	55, 72, or 120 pairs/sec
Data rate	4800 or 9600 baud (software selectable)
Coding	Binary 5-byte format. The first byte contains synchronization, button status, and proximity information. Second and third byte have absolute X coordinate position. The fourth and fifth byte have absolute Y coordinate position. Each byte is found by one start bit, and one stop bit. The data byte contains 8 bits of data and 1 bit for parity (odd parity).

(Continued on next page)

Table A-5: Tablet Specifications (Cont.)

Coordinate origin	Lower left corner of active area
Operating Modes	
Remote request	XY coordinate update and prox report when polled by host
Incremental	Position reports are generated as long as cursor is in motion. Reports are also generated when the buttons are pressed or released.
Diagnostics	Built-in diagnostics that check electronics, communication, tablet, and transducers
Interface	
Description	EIA RS232C compatible signals
Power requirements	+ 12 V DC +/- 10% at 0.3 A
Output connector (Power and Data)	7-Pin Micro-Din (male)
Mating connector	7-Pin Micro-Din (female)
Pin assignments	7 Pin (RS232C)
	<i>Pin Function</i>
	1 signal and power signal
	2 transmit data (from tablet)
	3 receive data
	4 not used
	5 not used
	6 +12 V
	7 tablet present

Table A-6: RD52 Fixed Disk Drive Specifications**Storage**

Total capacity	33,554,432 bytes
User capacity	30,965,760 bytes
User capacity	60,480 blocks

Performance

Average seek time	49.00 msec*
Average rotational latency	8.33 msec*
Average access time	57.33 msec*

Physical

Height	3.25 in (8.25 cm)
Width	5.75 in (14.60 cm)
Depth	8.00 in (20.32 cm)
Weight	7.00 lb (3.18 kg)

*When operating with RQDX2 or RQDX3 controller

Table A-7: RD53 Fixed Disk Drive Specifications**Storage**

Total capacity	71,303,168 bytes
User capacity	70,987,776 bytes
User capacity	138,648 blocks

Performance

Average seek time	30.00 msec*
Average rotational latency	8.33 msec*
Average access time	38.33 msec*

(Continued on next page)

Table A-7: RD53 Fixed Disk Drive Specifications (Cont.)

Physical

Height	3.25 in (8.25 cm)
Width	5.75 in (14.6 cm)
Depth	8.00 in (20.32 cm)
Weight	7.00 lb (3.18 kg)

*When operating with RQDX2 or RQDX3 controller

Table A-8: RX50 Dual Diskette Drive Specifications

Specifications

Diskettes/RX50 drive – 2

Number of recording surfaces/diskette – 1

Storage capacity

Per diskette	(80 tracks) 409,600 bytes
Per track	(10 sectors) 5,120 bytes
Per sector	(1 logical block) 512 bytes

Performance

Average seek time	164 msec*
Average rotational latency	100 msec*
Average access time	264 msec*

Specifications

Height	3.25 in (8.5 cm)
Width	5.75 in (14.6 cm)
Depth	8.50 in (21.6 cm)
Weight	4.18 lb (2.8 kg)

* When operating with RQDX2 or RQDX3 controller

Table A-9: TK50 Tape Drive Specifications**Specifications**

Recording media	Magnetic tape
Tape dimensions	0.5 in wide 600 ft long
Mode of operation	Streaming
Read/Write method	Serpentine
Recording density	6667 bits/in
Number of tracks	22

Capacity

Unformatted	131.0 mb
Formatted	94.5 mb

Performance

Tape start time	300 msec maximum*
Tape speed	75 in/sec*
Streaming data rate	500 kb/sec*
Access time (from insertion of a new tape)	1 min minimum* 35 min maximum*

Physical Specifications

Height	3.25 in (8.25 cm)
Width	5.75 in (14.60 cm)
Depth	8.44 in (21.44 cm)
Weight	5 lb (2.27 kg)

* When operating with RQDX2 or RQDX3 controller

Application program

A program designed to perform a task, such as a program that monitors a manufacturing process.

ASCII

American Standard Code for Information Interchange. A set of 8-bit binary numbers representing the alphabet, punctuation, numerals, and other special symbols used in text representation and communications protocol.

Asynchronous multiplexer

A device that controls and alternates the transmission of signals, so that more than one signal can be transmitted over a single communications line. The data being transmitted contains synchronizing information in the form of start and stop signals.

Backplane

A connector block that connects modules through a bus and provides physical support of those modules.

Back up

The process of making copies of the data stored in your disk drive(s) so that you can recover that data after an accidental loss. You make these "back-up" copies on RX50 diskettes or TK50 magnetic tape cartridges.

Back-up copy

A copy of data contained on your fixed disk. The duplicate is stored on either RX50 diskettes or TK50 magnetic tape cartridges.

Baud rate

The speed at which signals are serially transmitted along a communications line. One baud equals one bit/second.

Bezel

A cover used to hold and position the edges of a device, such as the free-standing disk subsystem of the VAXstation II.

Binary

A number system that uses 2 digits: 0 and 1. These digits are represented in VAXstation II circuitry by two voltage levels. VAXstation II programs are executed in binary form.

Bit

A binary digit; the smallest unit of information in a binary system of notation, designated as a 0 or a 1.

Bit-map

The type of graphics supported by the VAXstation II. With bit-map graphics, the workstation software can individually access each dot (pixel) on the video screen.

Boot

(See Bootstrap.)

Bootable medium

A fixed disk, diskette, or magnetic tape cartridge containing software (such as an operating system), which a bootstrap program can load into the VAXstation system memory and begin program execution.

Bootstrap

1. A program that you start when you turn on the VAXstation II. The bootstrap loads software contained on fixed disk, diskette, or magnetic

tape cartridge into memory; the VAXstation II stops executing the bootstrap and starts executing the software in memory. The software usually loads an operating system or other software into memory so that the VAXstation II can start processing.

2. To use a bootstrap program.

Bus

A printed circuit board that is part of the backplane. The bus permits the sharing of signals among the VAXstation II printed circuit boards.

Byte

A group of eight binary digits (bits). A byte is one-quarter of the size of a VAXstation II word.

Central processing unit (CPU)

The part of a VAXstation II system that controls the interpretation and execution of instructions. In the VAXstation II system, CPU functions are contained on one VAXstation II CPU chip.

Command

An order you can give to the VAXstation II, often through a terminal keyboard.

Communications line

A cable along which electrical signals are transmitted. Devices or VAXstation II systems that are connected by communications lines can share information and resources.

Computer system

A combination of VAXstation II hardware and software and external devices that perform specific operations or tasks.

Controller

A VAXstation II component, usually a printed circuit board, that regulates the operation of one or more peripheral devices. Controllers are often called interface units.

Control panel

The panel on the front of the VAXstation II cabinet that contains control switches and indicator lights.

CPU

Central processing unit.

Data

A representation of facts, concepts, or instructions in a formalized manner suitable for communication, interpretation, or processing by humans or by automatic means.

Data transmission

The movement of data in the form of electrical signals along a communications line.

Debug

To detect, locate, and correct errors (bugs) in system hardware or software.

DECnet

DIGITAL communication network.

Device

The general name for any unit connected to the VAXstation II that is capable of receiving, storing, or transmitting data. (See Input device, Output device, Input/output device, and Controller.)

Device name

The name by which a device or controller is identified in a VAXstation II system. The name you use to refer to that device when you are communicating with the system.

Diagnostic program

A program that detects and identifies abnormal VAXstation II hardware operation. The VAXstation Maintenance System software contains several diagnostic programs.

Disk

A flat circular plate with a coating on which data is magnetically stored in concentric circles (tracks). VAXstation II disks include the RD51, RD52, or RD53 fixed disk and the RX50 diskette.

Disk drive

A device that contains a fixed disk or one or more diskettes. The drive contains mechanical components that spin the disk or diskettes and move the read/write heads that store and read information on the surface of the disk or diskettes.

Diskette

A flexible disk contained in a square paper envelope. (See Disk.)

Diskette drive

A device that holds RX50 diskettes. (See Disk drive.)

Dot matrix

A method of generating characters for printing, using an array of dots from which combinations of dots produce readable characters.

Down-line load

To send a copy of a system image or other file over a line to the memory of a target node.

Error message

A message displayed by the VAXstation II to indicate a mistake or malfunction.

File

A collection of related information treated by the VAXstation II as a single item.

Formatted data

A pattern of data that conforms to a predetermined structure dictated by the system software.

GKS

Graphics Kernel System. GKS acts as the graphics interface for the VAXstation II.

Hard-copy terminal

A terminal that displays information on paper. Compare to video terminal.

Hardware

The physical components — mechanical and electrical — that make up a VAXstation II system. Compare to software.

Head

The part of a fixed disk drive, diskette drive, or tape drive that reads, records, and erases data. Also called read/write head.

Host

The primary or controlling computer in a multiple computer network.

Input device

A piece of equipment that is used to transfer data to the VAXstation II. For example, a keyboard is an input device.

Input/output (I/O) device

A piece of equipment that accepts data for transmission both to (input) and from (output) a VAXstation II. For example, a terminal.

Interactive

The method of communicating with a VAXstation II system. You type a command at the keyboard, the system executes the command and responds with a prompt character (usually) for another command.

Interface

A device or piece of software that allows the components of a VAXstation II to communicate.

I/O

Abbreviation for input/output.

K

The symbol that means 2 to the 10th power (or 1024 in decimal notation).

Kilobyte

1000 bytes.

LED

Light-emitting diode. LEDs are used as indicators on the control panel. A segmented LED display on the CPU distribution panel insert on the back of the VAXstation II cabinet displays the characters 0–9 and A–F during the power-on sequence to indicate CPU status and normal/abnormal operation.

Load

1. To move software (usually from a peripheral device) to memory.
2. To physically place a disk on a disk drive or a tape on a tape drive.

Local area network

A data communications system designed for a small geographic area that offers high-speed communications channels optimized for connecting information processing equipment. For example, Ethernet.

Magnetic tape

A strip of plastic coated with magnetic oxide and used for storing data. Often called magtape.

M

The symbol for 1024 squared (1,048,576 in decimal notation).

Megabyte

1,000,000 bytes.

Memory

The area of a VAXstation II that holds the instructions and data that temporarily store information.

Menu

A displayed list of options that you can select to run.

MicroVAX Workstation

Any workstation based on the 32-bit MicroVAX CPU. The workstations include the MicroVAX and the VAXstation systems.

MicroVMS Workstation Software

Window management software for a MicroVAX-based system. The system must run MicroVMS as the operating system. The system allows you to control and view several programs on one screen. You specify the window with which to interact by using a pointer.

Network

A group of individual computer systems that are connected by communications lines to share information and resources.

Node

An individual information-processing unit, such as a computer, workstation, or peripheral device, which is directly connected to a network.

Off-line

Pertaining to equipment, devices, and events that are not under direct control of the VAXstation II.

On-line

Pertaining to equipment, devices, and events that are in direct communication with the VAXstation II system.

Operating system

A collection of VAXstation II programs that control the operation of a VAXstation II and perform such tasks as:

- Assigning places in memory to programs and data
- Processing requests and scheduling jobs
- Controlling the operation of input and output devices

Output device

A device that extracts data from a VAXstation II system. For example, a printer.

Peripheral device

Any device distinct from the central processing unit that provides the CPU with additional memory storage or communication capability. Examples are disk and diskette drives, video terminals, and printers.

Power-up sequence

A series of ordered events that occur when you supply power by turning on the system.

Printer

A peripheral device that provides paper copies of information stored on a VAXstation II.

Program

The sequence of instructions a VAXstation II needs to perform a task. (See Software.)

Prompt

A word or words that a VAXstation II displays to indicate that the VAXstation II is waiting for you to type a command.

Read-only memory (ROM)

A memory that does not allow modification of its contents. The VAXstation II can use the data contained in a ROM but cannot change it.

Reboot

To restart a VAXstation II system. Pressing the Restart button on the control panel reboots the VAXstation II system (if the Halt-Enable/Disable switch on the back of the VAXstation II cabinet is in the up – enable – position).

ROM

Read-only memory.

Run

1. A single continuous execution of a program.
2. To execute a program.

Software

Programs executed by a VAXstation II system to perform a chosen or required function. Compare to hardware.

Storage medium

Any device capable of recording information, for example, a diskette.

Store

To enter data in a storage device, such as a disk, or into memory.

System

A combination of VAXstation II hardware and software and external devices that perform specific processing operations.

System image

The image that is read into memory from disk when the system is started up.

System management

Tasks performed by the operating system that control the operation of the VAXstation II system.

Tektronix 4014

A storage-tube display terminal sold by Tektronix, Inc.

Terminal

An input/output device that allows you to communicate with the VAXstation II system. Terminals are divided into two basic categories: video and hard-copy.

32-bit

Length of internal data path of CPU. It provides more concentrated data, allows more data types, and enables more data to be transferred at one time than a 16-bit internal data path.

Video terminal

A terminal that displays information on the screen of a cathode ray tube (CRT). Compare to hard-copy terminal.

VT100

An ANSI-compatible terminal offered by DIGITAL.

Winchester disk

A hard disk permanently sealed in a drive unit to prevent contaminants from affecting the read/write head.

Word

The largest number of bits (32) that the VAXstation II can handle in an operation. VAXstation IIs can also handle longwords (that is, two words or 64 bits).

Write-protect

To protect a disk, diskette, or other storage medium from the addition, revision, or deletion of information.

Write-protect notch

The small notch on the side of an RX50 diskette that you cover with an adhesive-backed label or tab to prevent loss of data by accidental overwriting.

Write-protect switch

The switch that you slide down on a TK50 tape cartridge to prevent loss of data by accidental overwriting.

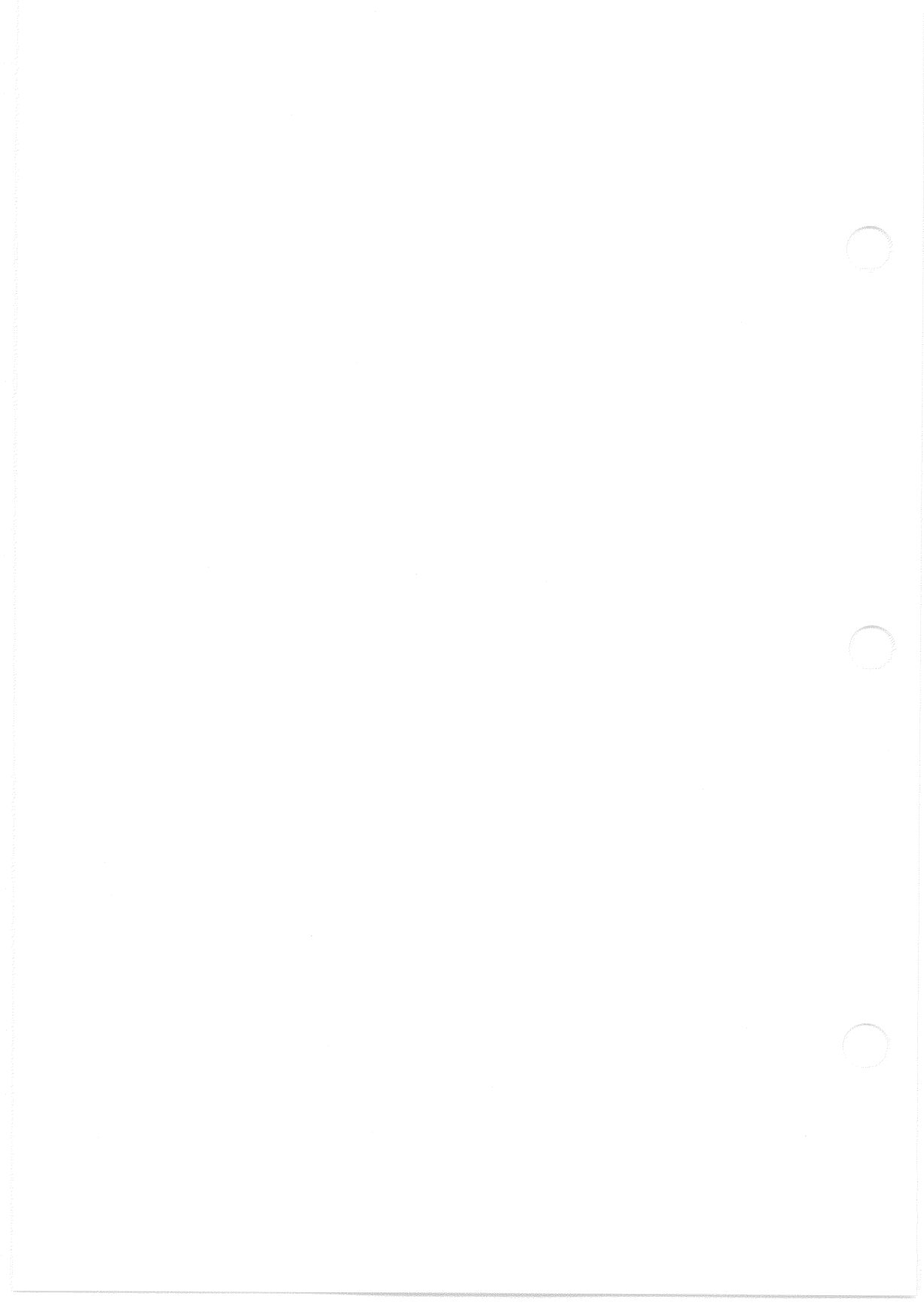

A

Accessories kit
 components, 1-2

C

Consolidation carton
 components, 1-2

D

Diagnostics
 configuration and devices
 screen, 5-10
 diskette, 1-2
 exiting diagnostics, 5-10
 field service menu, 5-10
 initial display, 2-26
 initial testing, 2-25
 introductory display, 2-36
 main menu display, 2-37
 maintenance system main
 menu, 5-9
 mode switch, 2-38
 power-on test, 2-36
 RX50 diskette, 2-21
 RX50 diskette insertion, 2-22
 setting date and time, 2-26

 system utilities menu, 5-10
 test screen, 2-27
 testing with the RX50, 2-28
 testing with the TK50, 2-31
 TK50 tape, 2-31
 TK50 tape insertion, 2-32

Disk drive, fixed
 description, 3-11
 location, 3-11

Disk drive, free-standing
 installation, 4-1

Diskette
 back-up, 3-23
 description, 3-13
 drive, 3-13
 handling, 3-15
 insertion, 3-16
 labeled, 3-14
 overwrite protection, 3-15
 RX50 information, 3-14
 storage, 3-15

DMV11
 description, 4-12
 installation, 4-1

Documentation
 hardware user information,
 1-2

DZQ11

- description, 4-12
- installation, 4-1

E

Ethernet

- DELNI connection, 2-17
- DEQNA, 3-12
- H4000 transceiver connection, 2-17
- site-preparation, 1-6

Ethernet controller module

- description, 3-12

F

Free-standing disk subsystem

- picture of, 4-11

Front control panel

- controls and indicators, 3-1
- DC OK indicator, 3-3, 3-4
- fixed disk pushbuttons, 3-5
- halt pushbutton, 3-4
- indicators, 3-1
- power switch, 3-3
- Restart/Run pushbutton, 3-3
- Run indicator, 3-3

G

GKS, viii

- Graphics Kernel System, viii

H

Hardware support kit

- components, 1-2

K

Keyboard

- cable assembly connection, 2-11
- installation, 2-10

L

LA210

- description, 4-4
- installation, 4-1
- picture of, 4-4
- system unit connection, 4-7

LA50

- description, 4-3
- installation, 4-1
- picture of, 4-3
- system unit connection, 4-7

Labels

- floor-stand unit, 2-14
- placement of, 2-14
- table-top unit, 2-14

LN03

- picture of, 4-6

LN03-AA

- description, 4-5
- installation, 4-1
- system unit connection, 4-7

M

Memory module

- installation, 4-1
- types, 4-10

Monitor

- brightness control, 2-26
- cable assembly connection, 2-6
- contrast control, 2-26
- controls, 2-26
- controls and indicators, 3-8

- front and side controls, 3–8
 - fuse replacement, 5–11
 - installation, 2–1
 - keyboard connection, 2–10
 - physical specifications, 1–4
 - placement, 2–1
 - power cord, 2–20, 2–23
 - power switch, 2–2, 2–22
 - power-up, 2–25
 - rear controls and connectors, 3–9
 - site preparation, 1–3
 - system unit connection, 2–17
 - testing, 2–25
 - tilt-swivel base assembly, 2–4
 - video cable connection, 2–17
 - video connection, 2–6
 - voltage select switch, 2–8
- M**
- Mouse
 - installation, 2–12
 - use of, viii
 - Multiplexer interface module
 - DZQ11 installation, 4–1
- O**
- Options**
- DZQ11 multiplexer interface module, 4–12
 - free-standing disk subsystem, 4–11
 - installation, 4–1
 - list of, 4–1
 - memory modules, 4–10
 - RD52–D disk subsystem, 4–11
 - RD53–D disk subsystem, 4–11
 - tablet, 4–9
- P**
- Pointing device
 - installation, 2–12
 - Printers
 - installation, 4–1
 - types, 4–2
- R**
- RD52–D subsystem
 - installation, 4–1
 - RD53–D subsystem
 - installation, 4–1
 - Related documents, ix
- S**
- Service
 - procedures, 6–1
 - telephone number, 6–1
 - types of, 6–2
 - Shipment components
 - listing, 1–2
 - Site preparation
 - environment, 1–6
 - monitor, 1–4
 - power requirements, 1–5
 - space planning, 1–3
 - Software carton
 - components, 1–2
 - Synchronous Line Controller, 4–12
 - installation, 4–1
 - System unit
 - adjusting baud rate, 2–16
 - connecting video cable, 2–17
 - control panel, 2–4
 - cover removal, 2–15
 - CPU distribution panel, 2–16
 - diskette drive, 3–13
 - ethernet connection, 2–12
- Index–3

- front control panel, 3-1
- installation, 2-1
- labels, 2-14
- physical specifications, 1-4
- power cord, 2-20
- power off, 2-22
- setting controls, 2-16
- site preparation, 1-3
- testing, 2-28
- voltage setting, 2-21

T

Tablet

- components, 4-9
- description, 4-9
- installation, 2-12
- specifications, 4-9

Tape

- back-up, 3-23
- cartridge release handle, 3-17
- description, 3-17
- drive, 3-17
- handling, 3-19
- insertion, 3-20
- labeling, 3-19
- Load/Unload button, 3-17
- overwrite protection, 3-20
- rewinding, 3-22
- storage, 3-19
- unloading, 3-22

Tilt-swivel base

- installation, 2-4

Tilt-swivel base assembly

- labeled, 2-4

Troubleshooting

- basic, 5-1
- maintenance system, 5-8
- monitor, 5-11
- power-up, 5-7
- procedure, 5-1

V

VAXstation II

- carton components, 1-1
- described, vii
- options, vii
- power-up, 3-9
- service, 6-1
- shipment components, 1-1
- site preparation, 1-3
- software, 2-42
- software installation, 2-42
- testing, 2-25
- troubleshooting, 5-1
- turning off, 3-9
- turning on, 3-8

W

Windows

- described, vii

HOW TO ORDER ADDITIONAL DOCUMENTATION

From	Call	Write
Chicago	312-640-5612 8:15 A.M. to 5:00 P.M. CT	Digital Equipment Corporation Accessories & Supplies Center 1050 East Remington Road Schaumburg, IL 60195
San Francisco	408-734-4915 8:15 A.M. to 5:00 P.M. PT	Digital Equipment Corporation Accessories & Supplies Center 632 Caribbean Drive Sunnyvale, CA 94086
Alaska, Hawaii	603-884-6660 8:30 A.M. to 6:00 P.M. ET or 408-734-4915 8:15 A.M. to 5:00 P.M. PT	
New Hampshire	603-884-6660 8:30 A.M. to 6:00 P.M. ET	Digital Equipment Corporation Accessories & Supplies Center P.O. Box CS2008 Nashua, NH 03061
Rest of U.S.A., Puerto Rico*	1-800-258-1710 8:30 A.M. to 6:00 P.M. ET	
<p>*Prepaid orders from Puerto Rico must be placed with the local DIGITAL subsidiary (call 809-754-7575)</p>		
Canada		
British Columbia	1-800-267-6146 8:00 A.M. to 5:00 P.M. ET	Digital Equipment of Canada Ltd 940 Belfast Road Ottawa, Ontario K1G 4C2 Attn: A&SG Business Manager
Ottawa-Hull	613-234-7726 8:00 A.M. to 5:00 P.M. ET	
Elsewhere	112-800-267-6146 8:00 A.M. to 5:00 P.M. ET	
Elsewhere		Digital Equipment Corporation A&SG Business Manager*

*c/o DIGITAL's local subsidiary or approved distributor



READER'S COMMENTS

NOTE: This form is for document comments only. DIGITAL will use comments submitted on this form at the company's discretion. If you require a written reply and are eligible to receive one under Software Performance Report (SPR) service, submit your comments on an SPR form.

Did you find this manual understandable, usable, and well organized? Please make suggestions for improvement.

Did you find errors in this manual? If so, specify the error and the page number.

Please indicate the type of user/reader that you most nearly represent.

- Assembly language programmer
- Higher-level language programmer
- Occasional programmer (experienced)
- User with little programming experience
- Student programmer
- Other (please specify) _____

Name _____ Date _____

Organization _____ Telephone _____

Street _____

City _____ State _____ Zip Code _____
or Country

Do Not Tear — Fold Here and Tape

digital



NO POSTAGE
NECESSARY
IF MAILED
IN THE
UNITED STATES

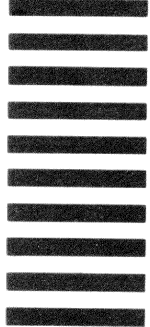

BUSINESS REPLY MAIL
FIRST CLASS PERMIT NO. 33 MAYNARD MASS.

POSTAGE WILL BE PAID BY ADDRESSEE

DIGITAL EQUIPMENT CORPORATION
SSG ML PUBLICATIONS, MLO5-5 E45
146 MAIN STREET
MAYNARD, MA 01754-2571

Do Not Tear — Fold Here

Cut Along Dotted Line

READER'S COMMENTS

NOTE: This form is for document comments only. DIGITAL will use comments submitted on this form at the company's discretion. If you require a written reply and are eligible to receive one under Software Performance Report (SPR) service, submit your comments on an SPR form.

Did you find this manual understandable, usable, and well organized? Please make suggestions for improvement.

Did you find errors in this manual? If so, specify the error and the page number.

Please indicate the type of user/reader that you most nearly represent.

- Assembly language programmer
- Higher-level language programmer
- Occasional programmer (experienced)
- User with little programming experience
- Student programmer
- Other (please specify) _____

Name _____ Date _____

Organization _____ Telephone _____

Street _____

City _____ State _____ Zip Code _____
or Country

Do Not Tear — Fold Here and Tape

digital



NO POSTAGE
NECESSARY
IF MAILED
IN THE
UNITED STATES

BUSINESS REPLY MAIL
FIRST CLASS PERMIT NO.33 MAYNARD MASS.

POSTAGE WILL BE PAID BY ADDRESSEE

DIGITAL EQUIPMENT CORPORATION
SSG ML PUBLICATIONS, MLO5-5 E45
146 MAIN STREET
MAYNARD, MA 01754-2571

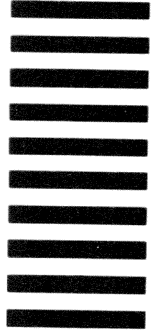

Do Not Tear — Fold Here

Cut Along Dotted Line

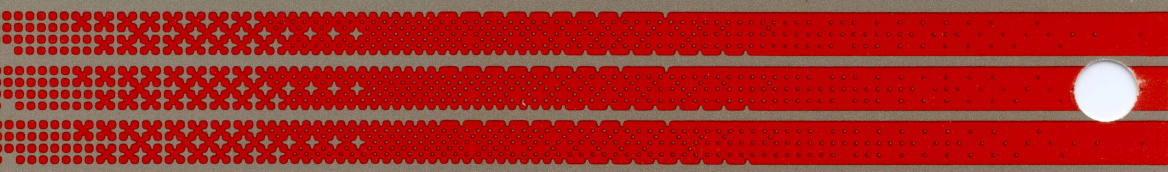

Digital Equipment Corporation • Maynard, MA 01754