

EK-MS88C-MI-001

# MS88-CA Memory Array Module

Maintenance Advisory

For Internal Use Only

**digital**™

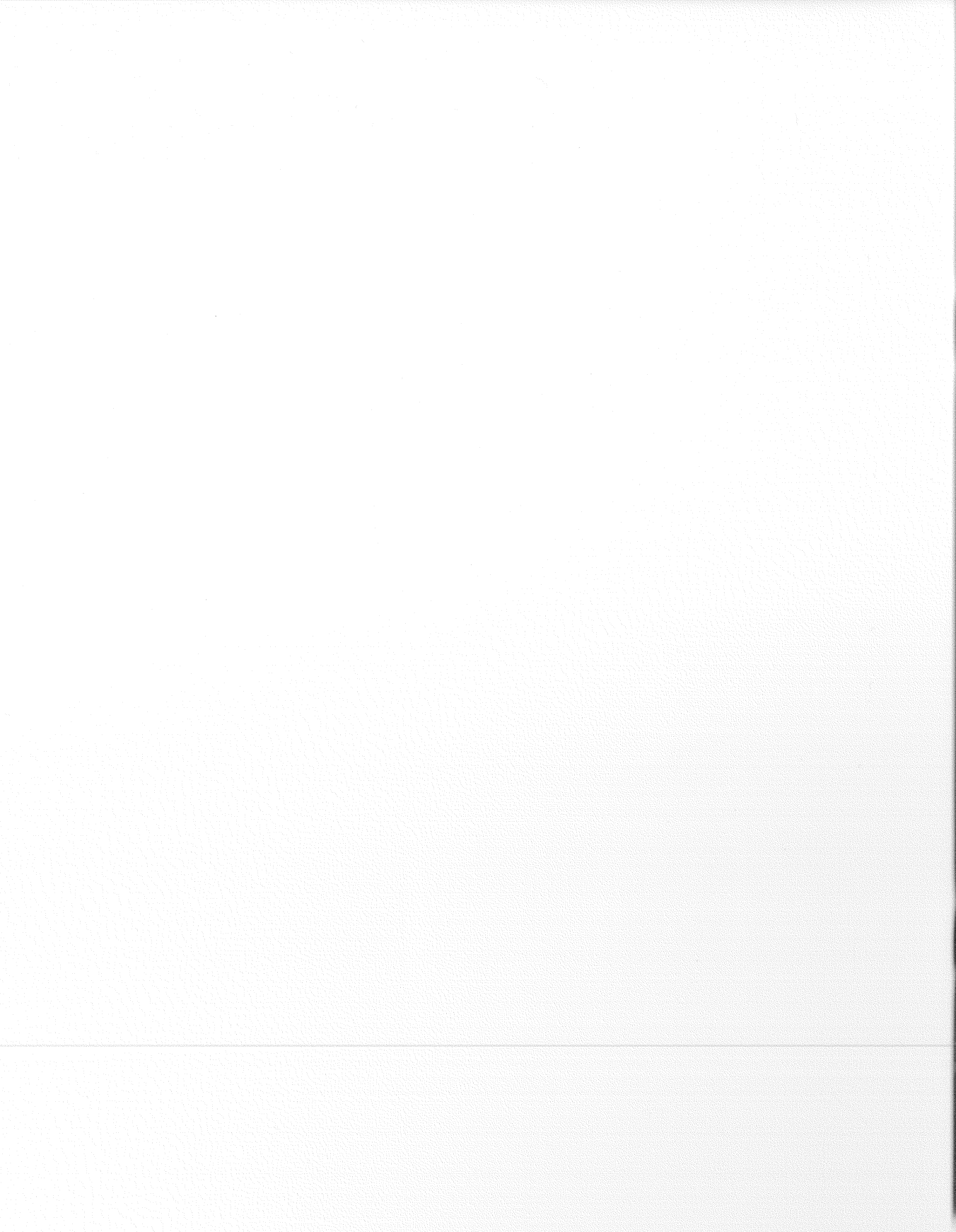

# MS88-CA Memory Array Module

Maintenance Advisory

For Internal Use Only

First Edition, January 1987

Copyright © 1987 by Digital Equipment Corporation.  
All Rights Reserved.  
Printed in U.S.A.

The reproduction of this material, in part or whole, is strictly prohibited. For copy information, contact the Educational Services Department, Digital Equipment Corporation, Marlboro, Massachusetts 01752.

The information in this document is subject to change without notice. Digital Equipment Corporation assumes no responsibility for any errors that may appear in this document.

Velostat is a trademark of the 3M Company.

The following are trademarks of Digital Equipment Corporation, Maynard, Massachusetts 01754.

<b>digital</b> ™	DIBOL	Rainbow	VAX
DEC	MASSBUS	RSTS	VMS
DECmate	PDP	RSX	VT
DECUS	P/OS	RT	Work Processor
DECwriter	Professional	UNIBUS	

CONTENTS

INTRODUCTION.....v

CHAPTER 1 MODULE DESCRIPTION.....1-1

CHAPTER 2 DOCUMENTATION.....2-1

CHAPTER 3 INSTALLATION PREREQUISITES.....3-1

3.1 Console Software/Diagnostics Revision D  
with V4.5 Update.....3-2

3.2 VMS Versions.....3-2

3.3 MCL Module Revisions.....3-3

CHAPTER 4 MAINTENANCE.....4-1

4.1 MS88-CA Daughterboard Replacement Procedure.....4-2

CHAPTER 5 MEMORY ERROR HANDLING.....5-1

5.1 Memory Errors During Initialization.....5-1

5.1.1 FIND/MEMORY Routine.....5-1

5.1.2 VMB Routine.....5-2

5.2 Memory Error Handling Under VMS.....5-3

5.2.1 ERF Entry (ANALYZE/ERROR).....5-4

CHAPTER 6 DIAGNOSTICS.....6-1

6.1 EZKBA Test 16 -- NAB Invalid Size/Configuration....6-3

6.2 EZKBB Test 24 -- Array March Test.....6-3

6.3 EZKBD Test 01 -- Array Moving Inversions.....6-5

CHAPTER 7 MS88-CA ADDRESS TRANSLATION.....7-1

GLOSSARY.....Glossary-1

FIGURES

4-1	MS88-CA Eight Daughterboards on the Motherboard....	4-3
6-1	MS88-CA Daughterboard Bank Numbers.....	6-2
7-1	MS88-CA Module (Component Side).....	7-2
7-2	MS88-CA Address Bit Allocation (VMS).....	7-5
7-3	MS88-CA Functional Diagram.....	7-5

TABLES

3-1	MCL Module Revisions.....	3-3
3-2	MCL Module/VMS Revision.....	3-4
5-1	ERF SMU Callout Conversion.....	5-6
7-1	MS88-CA Daughterboard Allocation.....	7-1
7-2	Failing SMU Identification.....	7-3
7-3	Sub-Bank/Address Bit Data.....	7-4

## INTRODUCTION

This advisory is for Digital Equipment Corporation's Field Service personnel who install and maintain the MS88-CA memory array modules on VAX 8500/8550 and VAX 8700/8800 systems. It should be used with the MS88-CA Memory Upgrade Installation Guide (EK-OMS88-IN).

The information in this advisory is detailed to ensure successful installation and maintenance of the MS88-CA. It should reduce the need for microdiagnostics and VMS for servicing the system. This information is for Field Service engineers as well as support personnel.

The first four chapters (Module Description, Documentation, Installation Prerequisites, and Maintenance) provide basic, "need-to-know" information that you should read before working on any system using the MS88-CA.

The final three chapters (Memory Error Handling, Diagnostics, and MS88-CA Address Translation) provide detailed technical descriptions for support personnel.

### NOTE

To install the MS88-CA successfully, make sure all the prerequisites are met (Chapter 3). You can, however, maintain the MS88-CA without meeting all the prerequisites as long as you understand the deficiencies to the system. The goal of this advisory is to document the maintenance procedures fully, including related prerequisites and deficiencies.

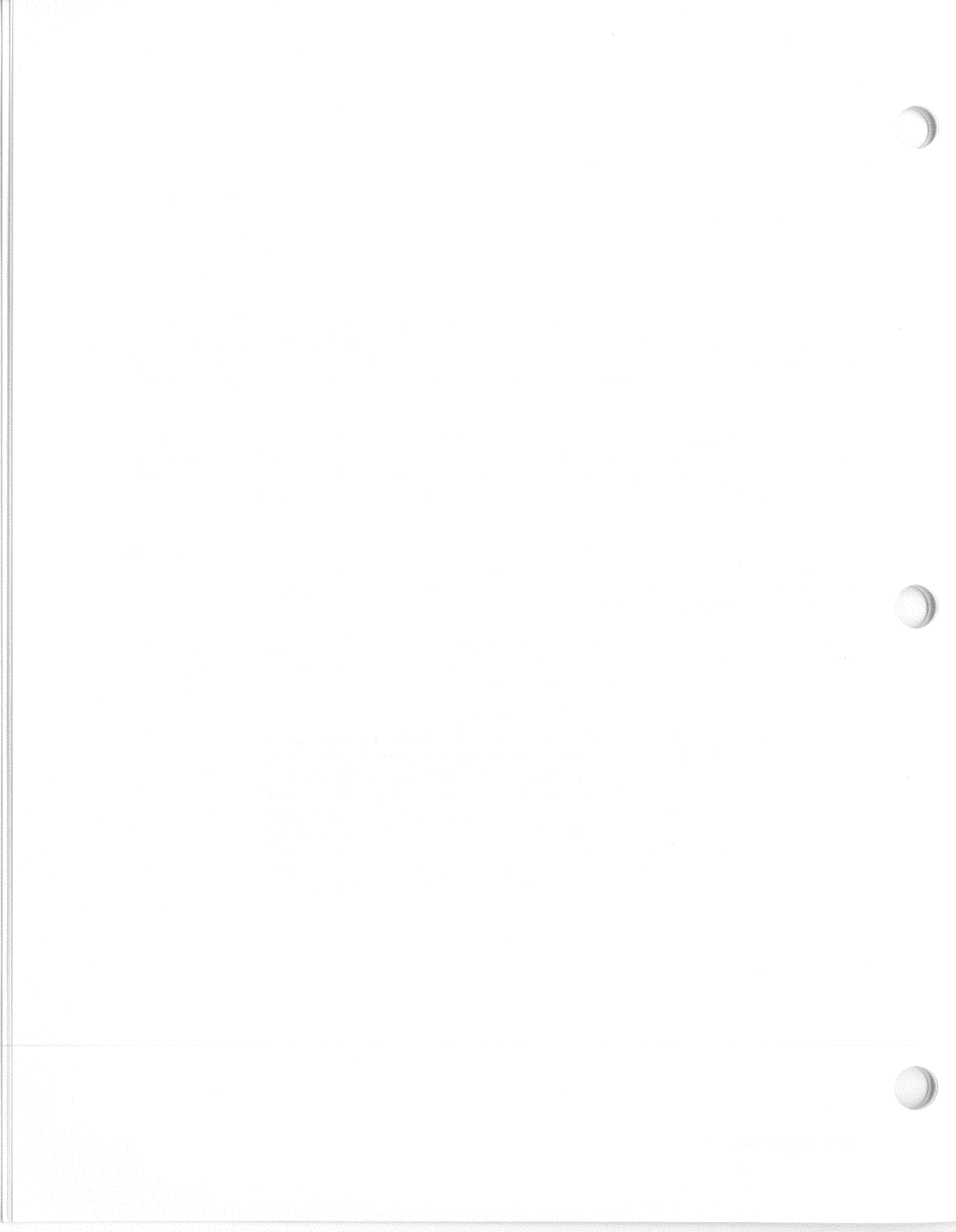



CHAPTER 1  
MODULE DESCRIPTION

The MS88-CA is a 16-Mbyte memory array module for the VAX 8500/8550/8700/8800 family of computer systems. It is similar in appearance to the MS86-CA used on the VAX 8600/8650 systems.

The MS88-CA consists of an extended hex, L-series motherboard populated with eight smaller daughterboards. The module can be embedded into new system building blocks (SBBs) (that is, shipped with new systems) or can be sold as an add-on option.

Two memory upgrade kits are available: the MS88-HA kit for VAX 8700/8800 systems, and the MS85-HA kit for VAX 8500/8550 systems. Each kit includes two MS88-CAs and a new backplane.

The motherboard-daughterboard configuration of the MS88-CA results in a much thicker module than the existing 4-Mbyte MS88-AA. To accommodate this extra thickness, two backplanes are available: one for the 8-slot VAX 8700/8800 and one for the 5-slot VAX 8500/8550. These backplanes have wider slots that allow the MS88-CA to be installed in every slot, providing maximum memory capacities of 8 modules  $\times$  16 Mbytes = 128 Mbytes for the VAX 8700/8800 and 5 modules  $\times$  16 Mbytes = 80 Mbytes for the VAX 8500/8550.

The MS88-CA can be installed in the old backplanes, but only in every other slot. This installation provides the maximum possible capacities of 4 modules  $\times$  16 Mbytes = 64 Mbytes for the VAX 8700/8800 and 3 modules  $\times$  16 Mbytes = 48 Mbytes for the VAX 8500/8550.

For more specific information on the configuration packages, see the Sales Update article listed as a reference in Chapter 2.

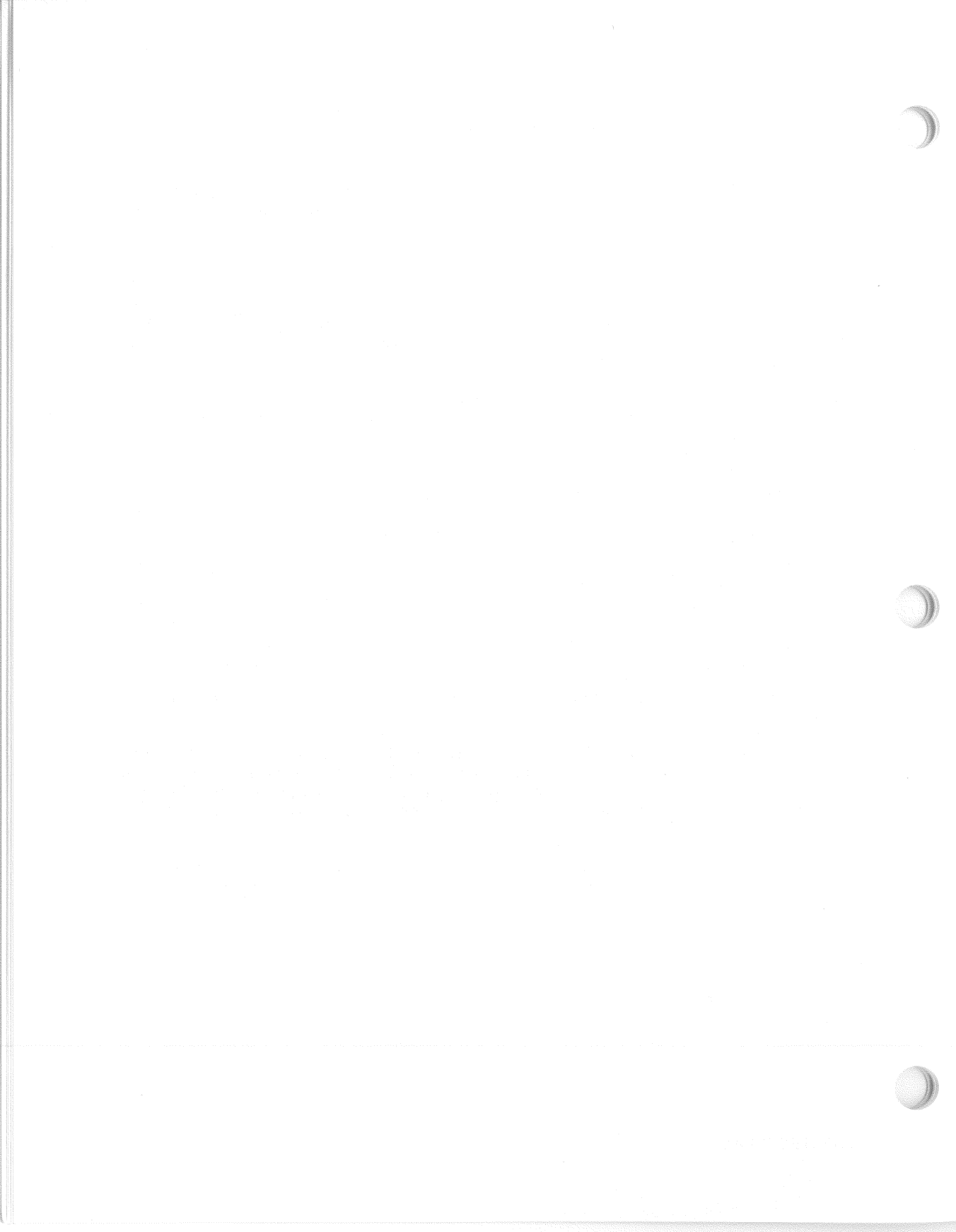

CHAPTER 2  
DOCUMENTATION

The MS88-CA Support Starter Kit for the MS88-CA includes the following documentation.

Title	Order Number
MS88-CA Field Maintenance Print Set	MP-02285
MS88-CA Memory Array Module Maintenance Advisory	EK-MS88C-MI
MS88-CA Memory Upgrade Installation Guide	EK-OMS88-IN

The installation guide is also shipped with all memory upgrade kits (MS85-HA and MS88-HA).

The support starter kit also includes the VAX 8500/8800 Microdiagnostic Upgrade Kit, which is made up of an RX50 diskette and a cover letter.

For more information, see the following related documents.

Title	Order Number
"Memory Expansion Packages for the VAX 8500, VAX 8550, VAX 8700, and VAX 8000." Sales Update/Special Issue (July 22, 1986): 29--31.	--
MS85-HA Field Maintenance Print Set	MP-02286
MS88-HA Field Maintenance Print Set	MP-02287
VAX 8800 System Maintenance Guide	EK-88XVx-MG*
VAX 8500/8550/8700/8800 Console User's Guide	AA-FH2C-TE

\*This guide is a 3-volume set where x is volume 1, 2, or 3.

Some of the related documentation has errors. Be sure to note the corrections given in the following paragraphs.

The VAX 8800 System Maintenance Guide (version 001) has the following errors.

- On page 7-38, the description of MEMORY CSR 1 <31:30> is incorrect. The function should be "Longword count." The description should read, "These bits are the longword count bits that point to the failing bank on an array card. This function allows the standard memory unit (SMU) or daughterboard to be identified as an FRU. These bits are loaded when the error page address is latched."
- On page 7-43, the table at the bottom of the page is incorrect. The size corresponding to a size code of 110 should be 64 Mbytes, not 32 Mbytes.
- On page 16-11, the mapping matrix is incorrect for the MS88-CA. See the correct matrix in Chapter 7 of this advisory.
- See page 17-7. As of VAX 8500/8800 Console Software/Diagnostic V4.0, the SELECT command in the microcode has a new switch. The new switch is SELECT BANK and is described in Chapter 6 of this advisory.
- On page 17-9, the VERIFY module name for any memory array card is simply MAR, not MARx.
- On page 17-12, the CSM TEMP register addresses are incorrect. The correct assignments for these registers are in the VAX 8500/8550/8700/8800 Console User's Guide on pages B-7 and B-8.

The VAX 8500/8550/8700/8800 Console User's Guide has an error on page D-3. The description for bit <16> (RPB\$VCRDTEST) is true when the bit is cleared for VMS V4.5 and earlier.

CHAPTER 3  
INSTALLATION PREREQUISITES

Make sure the following requirements are met before installing the MS88-CA or the MS85-HA/MS88-HA memory upgrade kits. You should observe these requirements also before installing any new system with MS88-CAs.

1. Read this advisory and the MS88-CA Memory Upgrade Installation Guide.
2. Make sure an MS88-CA spares kit (PN A2-W/M1138-10) is on site.
3. The system should run revision E (or later) console software/diagnostics, or it should run revision D console software/diagnostics and have the microdiagnostic V4.5 update installed.
4. The system should run VMS V4.6 or later.
5. The memory control logic (MCL) module (PN F1001) must be at revision D or later.

**WARNING**

If these prerequisites are not met,  
expect system deficiencies during instal-  
lation or maintenance.

Reading the documentation and providing the spares kit are required for the installation of any of Digital's products. The importance of meeting prerequisites 3, 4, and 5 are discussed in the following paragraphs.

3.1           **CONSOLE SOFTWARE/DIAGNOSTICS REVISION D WITH V4.5 UPDATE**  
To support the MS88-CA, the system should not run console software/diagnostics earlier than revision D (also called V4.0). The part number for this revision of the console is BT-ZMADD V22D or ZM920-C3-V22D. Without this revision, the system can neither boot nor diagnose the 16-Mbyte modules. V4.0 kits were distributed to all Field Service branches in August, 1986.

V4.0 of microdiagnostics EZKBB and EZKBD has faults related to the memory subsystem. Upon detection of certain failures, these microdiagnostics make incorrect callouts. The faults are not in V4.5, which was distributed to all Field Service branches in October, 1986, on an RX50 diskette. This upgrade kit is also in the support starter kit.

### 3.2           **VMS VERSIONS**

VMS V4.6 is required to support the MS88-CA fully. This version includes two fault corrections and an enhancement to memory.

- VMB, by default (with R5=0), maps those pages that have single-bit errors (SBES) or corrected read data (CRD) detected during the VMB memory test routine.
- VMB prints a warning if more than ten percent of memory is mapped during the VMB routine (as of VMS V4.5).
- The error reporting facility (ERF) correctly calls out the faulty SMU in the error log.

The system can run earlier versions of VMS (V4.4 or V4.5) to support the MS88-CA, but you must correct the following deficiencies.

- Modify the boot control file so that VMB can map those pages found with SBES/CRDs during the bootstrap memory test. Paragraph 5.1.2 describes how to modify the file.
- ERF calls out the correct faulty module but calls out the incorrect SMU for the MS88-CA. However, the register data in the error log entry is correct. (See the following note.) You can translate the data to determine the correct SMU. Paragraph 5.2.1 describes how to translate the data.

#### NOTE

The validity of the error log entry (for memory subsystem errors) is directly related to the revision of the MCL module. See Paragraph 3.3 for details.

### 3.3 MCL MODULE REVISIONS

The system must have revision D or later of the MCL module to support the MS88-CA. Table 3-1 can help you determine the revision of the module in any system.

#### NOTE

VMS ERF before V4.6 incorrectly decodes the contents of MEMORY CSR 0. Therefore, the revision levels printed by ERF are incorrect. (ERF refers to this revision as MEMORY REVISION LEVEL; it is specifically the MCL module's revision level.)

Earlier revisions of the MCL module have a fault. Incorrect data latches in MEMORY CSR 1 (the error page address register) when memory errors (single-bit or double-bit errors) are detected. This fault can cause incorrect SMU callouts with ERF. See Paragraph 5.2.1 for details.

Table 3-2 summarizes the interrelated problems of supporting the MS88-CA on systems with different versions of VMS and MCL modules.

Table 3-1 MCL Module Revisions

Source of Revision Information	MCL Module Revision			
	A	C	D	E
SHOW REV SENSE command	A	C	D	E
Module revision jumpers	5 (X)	7 (X)	8 (X)	9 (X)
MEMORY CSR 0 <23:20>	5	7	8	9
ERF (before V4.6)	E	H	J	K
ERF (V4.6 and later)	05	07	08	09
MSCL macro cell array (MCA) revision	-02	-03	-04	-04

Table 3-2 MCL Module/VMS Revision

VMS Version	MCL Module Revision C (or Earlier)	MCL Module Revision D (or Later)
4.3 or earlier	VMB maps fault.	VMB maps fault.
	VMB does not print mapout message.	VMB does not print mapout message.
	ERF ignores MS88-CA.	ERF ignores MS88-CA.
	ERF data is incorrect.	ERF identifies slot.
4.4	VMB maps fault.	VMB maps fault.
	VMB does not print mapout message.	VMB does not print mapout message.
	ERF data is incorrect.	ERF identifies slot, but SMU is wrong.
4.5	VMB maps fault.	VMB maps fault.
	ERF data is incorrect.	ERF identifies slot, but SMU is wrong.
4.6 or later	ERF data is incorrect.	All okay.



The Field Service engineer should maintain the MS88-CA by using the FRU replacement strategy.

The MS88-CA is made up of nine FRUs.

- The motherboard (PN L0115-00)
- Eight daughterboards (SMUs) (PN 54-16500-BA)

NOTE

The FRU strategy is to isolate and replace either the motherboard or the daughterboard. Do not replace the entire module.

Two spares kits support the MS88-CA: one kit contains an unpopulated motherboard (PN L0115-00) and the other contains two daughterboards (PN 54-16500-BA). Each module is packaged in its own rigid plastic electrostatic discharge (ESD) container. The faulty module should be returned to Field Service Logistics in the container along with the completed nonconforming material tag.

NOTE

The 54-16500-BA daughterboards can be used on the 16-Mbyte MS86-CA (VAX 8600/8650) as well as the MS88-CA. However, the older 54-16500-AA daughterboards used on the MS86-CA cannot be used on the MS88-CA.

The VAX 8500/8550 and VAX 8700/8800 microdiagnostics and ERF support the FRU replacement strategy by providing isolation information to the motherboard and SMU level. The following guidelines can help you determine which error log entries require FRU replacement.

- Replace the FRU for all verified diagnostic failures (Chapter 6). This guideline is based on the ability of the diagnostics to detect and isolate hard errors.
- Replace the FRU for all read data substitutes (DBEs) that are verified to be caused by the memory FRUs (Chapter 5).

- Replace the FRU for repetitive correctable read data (CRD) error log entries that occur under VMS and reoccur after you reboot the system. This symptom probably indicates an intermittent failure in the memory subsystem that has gone undetected by the diagnostics and VMB, yet has occurred often enough under VMS to result in multiple error log entries.
- Replace the FRU if VMB maps an excessive number of pages during boot time. The exact number of pages depends on customer impact. Generally, if more than five percent of the total memory capacity is mapped, replace the faulty FRU.

Certain memory errors have little impact on the operation of the subsystem (similar to bad spots on a disk). You do not usually need to replace the FRU if these failures occur.

**NOTE**

**This information is only a guideline.  
Some cases can require FRU replacement.**

Some soft errors can result in a single CRD error log entry under VMS. If the error does not reoccur, then it was probably soft and should not require FRU replacement.

**4.1 MS88-CA DAUGHTERBOARD REPLACEMENT PROCEDURE**

Figure 4-1 shows the placement of the eight daughterboards on the motherboard.

Use the following procedure to remove a daughterboard from the motherboard.

1. Power off the system.
2. Open the front access door of the CPU cabinet.
3. Attach the ESD wrist strap to your wrist. (The strap is connected to the left side of the CPU frame assembly.)
4. Using the Velostat kit (PN A2-W0299-10), position the antistatic mat on top of the CPU cabinet. Then connect the ground strap to the CPU frame assembly.
5. Place the ESD container holding the spare daughterboard next to the antistatic mat. Then snap the CPU ground strap onto the ESD container. (The ground strap is mounted on the front left side of the CPU frame assembly.)
6. Open the access doors to the module card cage and remove the desired MS88-CA. Place the module on top of the antistatic mat, etch side down, with the backplane fingers facing you.

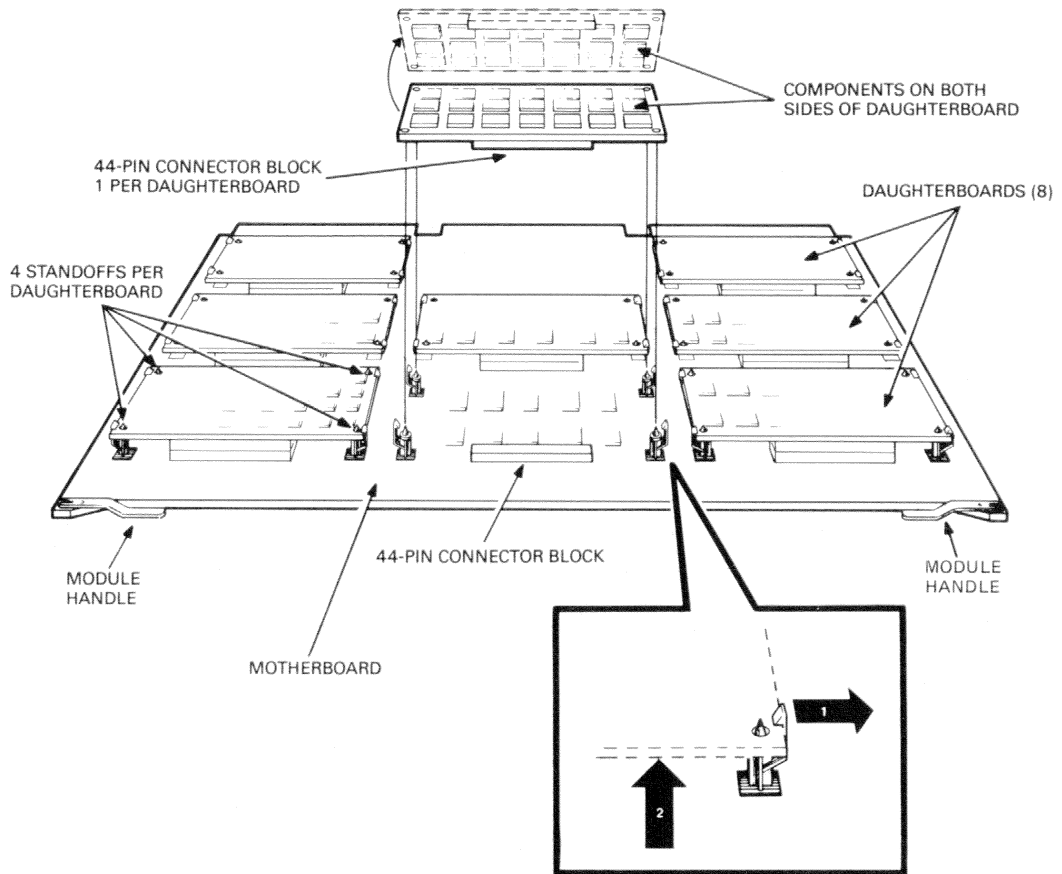

Figure 4-1 Eight Daughterboards on the Motherboard

7. To remove the desired daughterboard from the motherboard, push back the four corner standoff latches. Then gradually work the daughterboard up from the motherboard connector.

To install the spare daughterboard, perform this procedure in reverse. Be sure to place the removed daughterboard in the ESD container.



Two routines can detect memory-related errors when you initialize the VMS operating system during a cold boot: the FIND/MEMORY routine and the VMB memory test routine. Once VMS is running, a complex algorithm handles memory errors.

### 5.1 MEMORY ERRORS DURING INITIALIZATION

During system initialization (cold boot) and execution of the SYSINIT command, an INITIALIZE/MEMORY console command is executed. This command configures memory via the decode RAMs and initializes memory to a "known-good" state. A sample console output resulting from execution of the INITIALIZE/MEMORY command is shown below.

```
4-SEP-86 15:46:34***INFO,NO CONFIGURATION TABLE FOUND;CREATING ONE
```

SLOT #	# MEGABYTES	
	PRESENT	MAPPED
0	16	16
1	16	16
2	4	4

#### 5.1.1 FIND/MEMORY Routine

The FIND/MEMORY routine executes before loading and starting VMB. (The FIND/MEMORY console command is usually in the DEFBOO.COM file.) If this routine detects memory errors while verifying a 64-Kbyte section of memory (starting from memory location 0), it jumps to the next 64-Kbyte section and repeats the test. When the FIND/MEMORY routine finds a good 64-Kbyte section, it loads VMB and prints the starting address on the console with the EXAMINE/SP command:

```
G 0000000E 00000200
```

```
LOAD DONE,55 BLOCKS LOADED STARTING AT PHYSICAL ADDRESS =00000200
```

If the printed address is other than 00000200, the FIND/MEMORY routine probably detected errors and loaded VMB into a higher section of memory. If this happens, halt the boot process and run microdiagnostics to identify the failure.

Run microdiagnostics also if the FIND/MEMORY routine cannot find any good sections of memory. If this error occurs, the following error message prints on the console.

64KBYTES OF GOOD MEMORY NOT FOUND

### 5.1.2 VMB Routine

The VMB routine runs a quick 1s and 0s pattern test of all the memory. As of VMS V4.6, the default operation of VMB is to map VMS pages with double-bit or single-bit errors (SBEs, also called CRDs). With earlier versions of VMS (before VMS V4.6), the default operation does not cause VMB to map pages with SBES/CRDs. To change this default, simply modify the boot control file (DEFBOO.COM) to include the following command.

```
>>>DEPOSIT R5=10000
```

Setting bit <16> in boot parameter register R5 causes VMB to map pages with SBES/CRDs.

#### NOTE

Setting bit <16> applies only to VMS versions before V4.6.

Once VMS is running, you can use the SHOW MEMORY DCL command to see a count of the pages mapped by VMB. Look for the count under the subtitle "Static Bad Pages." See the following example.

```
$SHOW MEMORY
```

System Memory Resources on 13-Oct-1986 11:54:35.73

Physical Memory Usage(pages):	Total	Free	In Use	Modified
Main Memory (56.00Mb)	114688	89415	25189	84
Bad Pages	Total	Dynamic	I/O Errors	Static
	16384	0	0	16384

As of VMS V4.5, the console prints a warning if VMB maps more than ten percent of memory. A sample message is shown below.

```
%BOOT-W-Ten percent or more of main memory is bad
```

## 5.2 MEMORY ERROR HANDLING UNDER VMS

Once VMS is running, the algorithm for handling memory errors is complex. The following list just summarizes symptoms of memory errors under VMS. For more information, see the system maintenance guide.

- If more than 3 SBES/CRDs occur within 10 milliseconds, VMS writes an error log entry, disables CRD logging for 15 minutes, then enables logging.
- All SBES/CRDs increment the system's memory error count, which you can see by typing the SHOW ERROR DCL command. Even errors that occur when logging is disabled increment this count.
- SBES/CRDs are first logged into a memory error buffer (if logging is enabled). This buffer holds a maximum of 16 entries. The contents of this buffer are written to the system error log (via the error log buffer) if more than 3 entries occur within 10 milliseconds or if 16 entries occur.
- A double-bit error (DBE) causes a machine check to occur and VMS tries to recover the page in error. If successful, VMS maps the bad page (shown as a dynamic bad page with the SHOW MEMORY DCL command) and usual system operation continues. If unsuccessful, VMS crashes the user (if in user mode) or crashes the system with a fatal bugcheck.

Based on the VMS memory error handling algorithm and the symptoms previously listed, a typical memory error (such as a CRD) causes a high memory error count and many error log entries spaced about 15 minutes apart. To isolate this failure to an FRU, type the ANALYZE/ERROR DCL command to examine the error log entries. Then schedule downtime to run a diagnostic and replace the FRU.

### 5.2.1 ERF Entry (ANALYZE/ERROR)

This section outlines the format of the error reporting facility (ERF) entry for a memory error. A DCL command to extract this entry is as follows.

```
$ANALYZE/ERROR/INCLUDE=MEMORY
```

The error log entry for the MS88-CA is the same as for the MS88-AA with one exception: the addition of the SMUn attribute for MEMORY CSR 1. SMUn identifies the failing daughterboard(s) upon detection of a CRD or DBE. The following example shows where the SMU is identified. The example is annotated with numbers in brackets. The comments that follow have corresponding numbers.

```
VAX / VMS      SYSTEM ERROR REPORT      COMPILED 28-AUG-1986 12:08
                                                    PAGE 1.
```

```
***** ENTRY      4. *****
ERROR SEQUENCE 2856.                                LOGGED ON SID 06FFFFFF
CORRECTED MEMORY ERROR 26-AUG-1986 14:18:20.66      [1]
TOTAL NUMBER OF CORRECTED MEMORY EVENTS = 9.        [2]
CORRECTED MEMORY EVENT 1.                            [3]
MEMORY CSR 0    000800F0
                NMI ADAPTER CODE = F0(X)
                MEMORY REVISION LEVEL = J            [4]
MEMORY CSR 1    C39CF21E
                ARRAY NUMBER = 6.                    [5]
                ARRAY PRESENT
                WORD COUNT = 3.                       [6]
                SMU2.                                  [7]
MEMORY CSR 2    22003058
                SYNDROME = DATA BIT #12.            [8]
                CRD ERROR LOG REQUEST                [9]
MEMORY CSR 3    F0145145
                ARRAY #0. 16 MBYTE ARRAY
                ARRAY #1. NO ARRAY BOARD PRESENT
                ARRAY #2. 16 MBYTE ARRAY
                ARRAY #3. NO ARRAY BOARD PRESENT
                ARRAY #4. 16 MBYTE ARRAY
                ARRAY #5. NO ARRAY BOARD PRESENT
                ARRAY #6. 16 MBYTE ARRAY
                ARRAY #7. NO ARRAY BOARD PRESENT
                ENABLE DOUBLE BIT ERROR INTERRUPT
                ENABLE SINGLE BIT ERROR INTERRUPT
                ENABLE INTERLOCK TIMEOUT INTERRUPT
CORRECTED MEMORY EVENT 2.
```



The following paragraphs are comments on the previous ERF entry example.

1. This line contains the type of error log entry and the time stamp that the entry was made. In this example, the type is a corrected memory error, which is caused by SBES/CRDs. The time stamp is the time that VMS wrote the contents of the error log from the memory error buffer to the system error log buffer. This example has nine logged events; the time stamp is valid only for the last event. (You do not know the time of the first eight events.)
2. This line shows the total number of events in this entry. The total can be any number from 3 through 16.
3. This line is the heading for the first event.
4. This line identifies the revision of the MCL module. See Table 3-1. If the system is running VMS V4.4, a J in this line shows that the MCL module is revision D.
5. This line contains the array number (6 in this example). It identifies which array was being addressed when the error occurred. Because the MCL module is revision D, this slot number is accurate.
6. This line is the word count field (or bank select field), which is 3 in this example. This information is required to determine the correct SMU source.
7. The SMU callout in this line is not accurate because the system is running VMS V4.4. (VMS V4.6 or later is necessary for accurate SMU callouts.)
8. This line identifies the bit in error.
9. This line identifies the type of memory error. In this example, the error is a CRD.

The ERF in V4.4 and V4.5 of VMS has a fault that causes an incorrect SMU callout for the MS88-CA. The fault is in the decoding of MEMORY CSR1 <31:30>. In other words, for these versions of VMS (when a revision D MCL module is used), the contents of MEMORY CSR 1 <31:30> are correct, but the bit-to-text translation is incorrect.

To work around this problem, translate the word count field yourself to the correct SMU (Chapter 7) or use Table 5-1.

Table 5-1      ERF SMU Callout Conversion Chart  
(for VMS V4.4 and V4.5 only)

Callout	Correct SMU
SMU1	SMU8
SMU2	SMU4
SMU3	SMU6
SMU4	SMU2
SMU5	SMU7
SMU6	SMU3
SMU7	SMU5
SMU8	SMU1

## CHAPTER 6 DIAGNOSTICS

Microdiagnostics EZKBA, EZKBB, and EZKBD are the primary diagnostic tools for troubleshooting and verifying the MS88-CAs. By default, the TEST console command executes all of the memory microdiagnostics, except the moving inversions test (EZKBD TEST 01), on all of the memory.

Many tests run on the MS88-CAs. You can select these tests by using the VERIFY MODULE MAR microdiagnostic command:

```
MIC>VERIFY MODULE MAR
```

This command runs only those tests that verify the MS88-CAs. The command is valid for the MAR4 (4-Mbyte MS88-AA) and the MR16 (16-Mbyte MS88-CA).

You can also select a single MS88-CA and bank to save testing time. An example of these commands follows. When you test the MS88-AA, only the SELECT ARRAY command is useful because you always need to verify the entire module. With the MS88-CA, however, you can select a specific bank to test a specific pair of daughterboards.

```
MIC>select array=2  
Memory arrays selected: 2  
MIC>select bank=3  
Memory banks selected: 3  
MIC>diag/sect:ezkbb/test:24
```

Figure 6-1 shows the MS88-CA bank numbers for the daughterboards.

For further information on console and microdiagnostic commands, see the VAX 8500/8500/8700/8800 Console User's Guide and the VAX 8800 System Maintenance Guide.

Paragraphs 6.1 through 6.3 provide detailed information on three of the memory array tests. These tests have been selected due to their extensiveness and the hardware they check. For details on these and other tests, see the diagnostic microcode listings (which are well commented for reference).

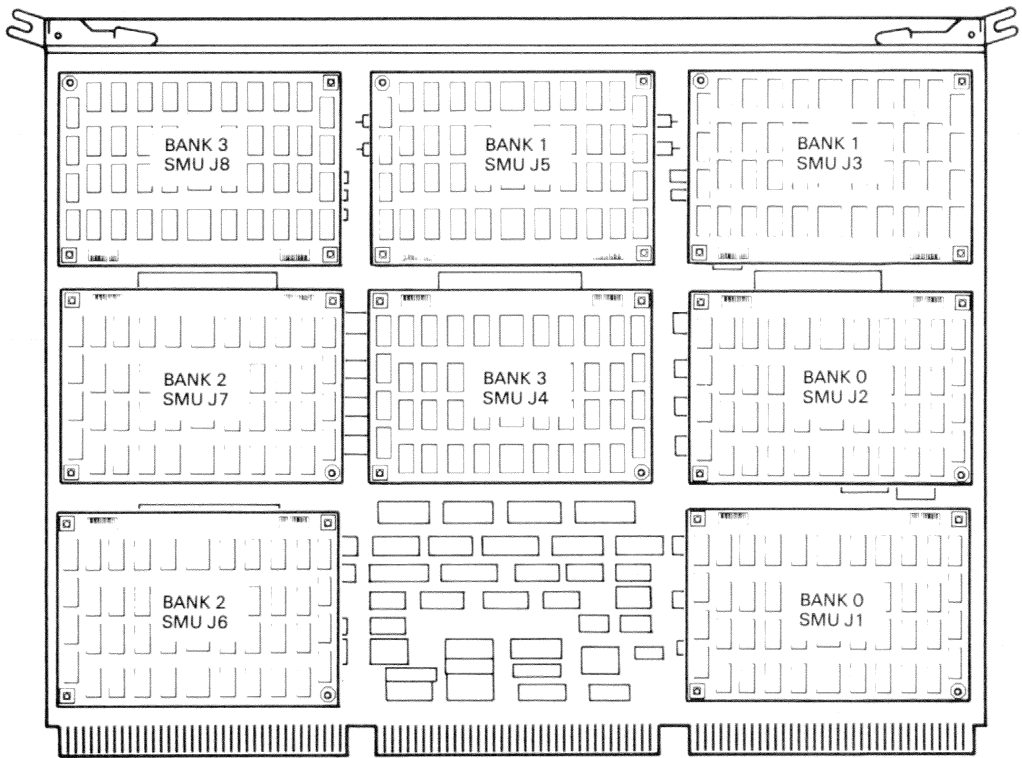

SHR0313-86

Figure 6-1 MS88-CA Daughterboard Bank Numbers

### 6.1 EZKBA TEST 16 -- NAB INVALID SIZE/CONFIGURATION

This test verifies the placement and configuration of the modules. When executed, the test prints the configuration of the modules, indicating the slot number and the size. If the configuration is not valid, the test fails and, due to the nature of the fault, can not isolate the fault. Therefore, when this test fails, first check the configuration printout and make sure it follows the configuration guidelines outlined in the MS88-CA Memory Upgrade Installation Guide. A sample failure printout follows.

TEST 15 - Decode RAM March

TEST 16 - NAB Invalid Size/Configuration NOTE: check CONFIGURATION

```
*** MAR Modules Found ***
```

SLOT#	Size in Bytes
00	01000000
01	01000000
02	00400000
03	01000000

18-JUN-86 07:22:37, DAIGNOSTIC DETECTED ERROR \*\*\*CPU FAILED\*\*\*  
EZKBA-REV 04.00 \*\*\* TEST 16-ERROR 03, PASS 01\*\*\*

FAILING HW: MCL, (MAR) SLOT 3  
SYNCH UPC: 0440

MIC>

The test failed because the configuration failed. Larger modules must be installed in lower numbered slots than smaller modules. The solution is to rotate the 16-Mbyte and 4-Mbyte modules in slots 3 and 2 respectively.

### 6.2 EZKBB TEST 24 -- ARRAY MARCH TEST

EZKBB test 24, the array march test, is the first test that runs patterns throughout memory. It is likely to be the first test to fail if memory has DRAM problems. The estimated runtime of this test (in default mode) is as follows.

Module	Memory	Bank Size	Runtime per Bank	Runtime per Module
MS88-AA	4 Mbytes	1 Mbyte	8 seconds	30 seconds
MS88-CA	16 Mbytes	4 Mbytes	30 seconds	2 minutes

When the test runs, it first prints the configuration of the modules (Paragraph 6.1). Next, the test prints an SBE status for each bank of memory as it cycles through all of the select arrays/banks. The test starts at the first location within the bank, then tests sequentially through memory. After each bank is tested, the test reports the SBE status:

```
*** SBEs Found ***      SLOT#      BANK      Soft SBEs      Hard SBEs
                          00         00         000000         000000
                          00         01         000000         000000
                          00         02         000000         000000
                          00         03         000000         000000
                          01         00         000000         000000
```

If an error occurs while a bank is being tested, an error message prints and the SBE status is not reported for the bank that failed. A sample error printout follows.

```
*** SBE Count ***          SMU J_
      0004000                J04
```

```
10-JUN-86 15:50:56, DIAGNOSTIC DETECTED ERROR
***CPU FAILED*** EZKBB-REV 04.50 *** TEST 24-ERROR 04, PASS 01***
```

```
      FAILING HW: (SMU_J4) SLOT 2
      SYNCH UPC: 0388
```

MIC>

A second failure example for EZKBB test 24 follows. In this example, the diagnostic listings can be used to determine the exact failure. The failure is a DBE (indicated by ERROR 01).

```
10-SEP-86 16:03:22, DIAGNOSTIC DETECTED ERROR
***CPU FAILED*** EZKBB-REV 04.05 ***TEST 24-ERROR 01, PASS 01***
```

```
      FAILING HW: (SMU_J4) SLOT 2
      SYNCH UPC: 09FC
```

The following example shows how to use CSM commands to extract more error information.

```
MIC>START/C 3000          ;start CSM
?NN      CPU halted      ;response from system
          PC = NNNNNNNN   ;
MIC>E R6                ;examine failing address register
          G 00000006 0180000C ;bad address is 0180000C
MIC>E R1                ;examine foreground data pattern
          G 00000001 AAAAAAAA ;(expected data)
MIC>E/T 19              ;examine received data pattern
          M 00000019 AAAAAAFA ;
```

If you compare the expected data (all As) with the received data, you can see that data bits <4> and <6> are stuck at 1.

### 6.3 EZKBD TEST 01 -- ARRAY MOVING INVERSIONS

This test does not run by default and runs only if you type the SET FLAG EXHAUSTIVE command. EZKBD is an extensive test of the module; it takes substantial time to run. The estimated runtime of this test follows.

Module	Memory	Bank Size	Runtime per Bank	Runtime per Module
MS88-AA	4 Mbytes	1 Mbyte	80 seconds	7 minutes
MS88-CA	16 Mbytes	4 Mbytes	7 minutes	28 minutes

When running, the test prints a status message at 5-second intervals for the MS88-AA and at 20-second intervals for the MS88-CA. The status message follows.

```
***Currently Testing*** SLOT#03 BANK02 ;;print every 5 seconds
```

The test also prints module and bank summaries for the total number of hard and soft SBES.

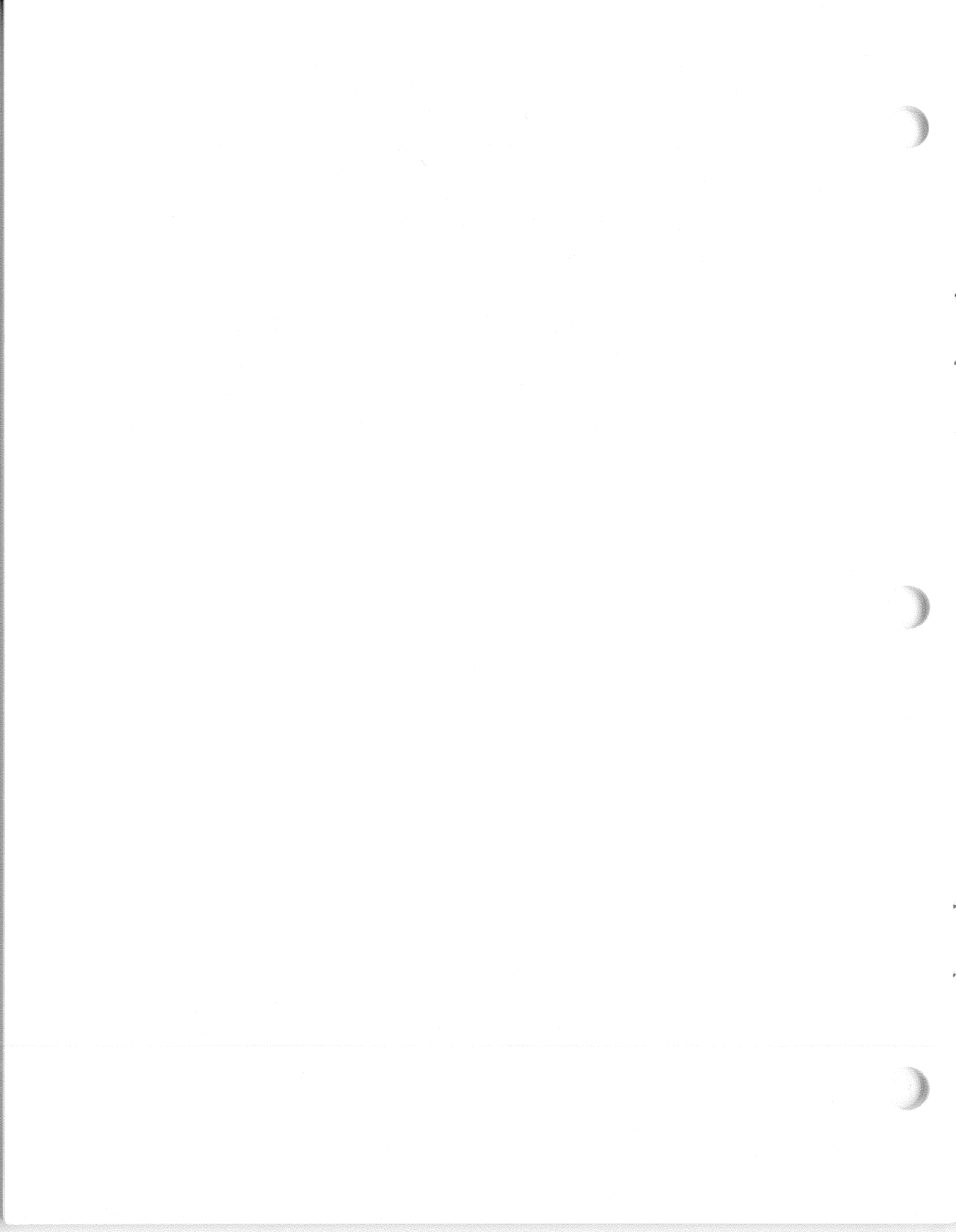



**CHAPTER 7**  
**MS88-CA ADDRESS TRANSLATION**

The information stored in the MEMORY CSRs upon the detection of an error is enough to isolate the source of the error. To isolate the failing module, use the decode RAM field from MEMORY CSR <02:00>, which indicates the slot number. The decode RAM is the same for all variations of the MS88 module.

The following paragraphs describe the mapping of NMI ADDR H within the MS88-CA. This information is useful for isolating a memory address to the failing component in the MS88-CA.

Logically, the MS88-CA is divided into 4 memory banks, with each bank containing 4 Mbytes of memory. Consecutive memory address accesses to the MS88-CA cycle through each of the banks, as address bits <03:02> select the appropriate bank. For example, the longword at memory address XXXXXX0 resides in bank 0, the longword at memory address XXXXXX4 resides in bank 1, XXXXXX8 in bank 2, XXXXXXC in bank 3, XXXXXX10 in bank 0, and so on.

Physically, each pair of daughterboards on the MS88-CA represents one bank of memory. Table 7-1 shows the allocation of these daughterboards and Figure 7-1 shows the location of the daughterboards.

On detection of an error, the MCL module saves the error page address in MEMORY CSR 1 (address 3E000004). NMI ADDRESS <03:02> H is stored in CSR 1 <31:30> as the word count. These two bits identify the failing bank or daughterboard pair.

**Table 7-1 MS88-CA Daughterboard Allocation**

NMI ADDRESS <03:02> H	AMCL CMD <01:00> L	MS88-CA Bank	Daughterboard Pair
00	11	0	J2 and J1
01	10	1	J5 and J3
10	01	2	J7 and J6
11	00	3	J4 and J8

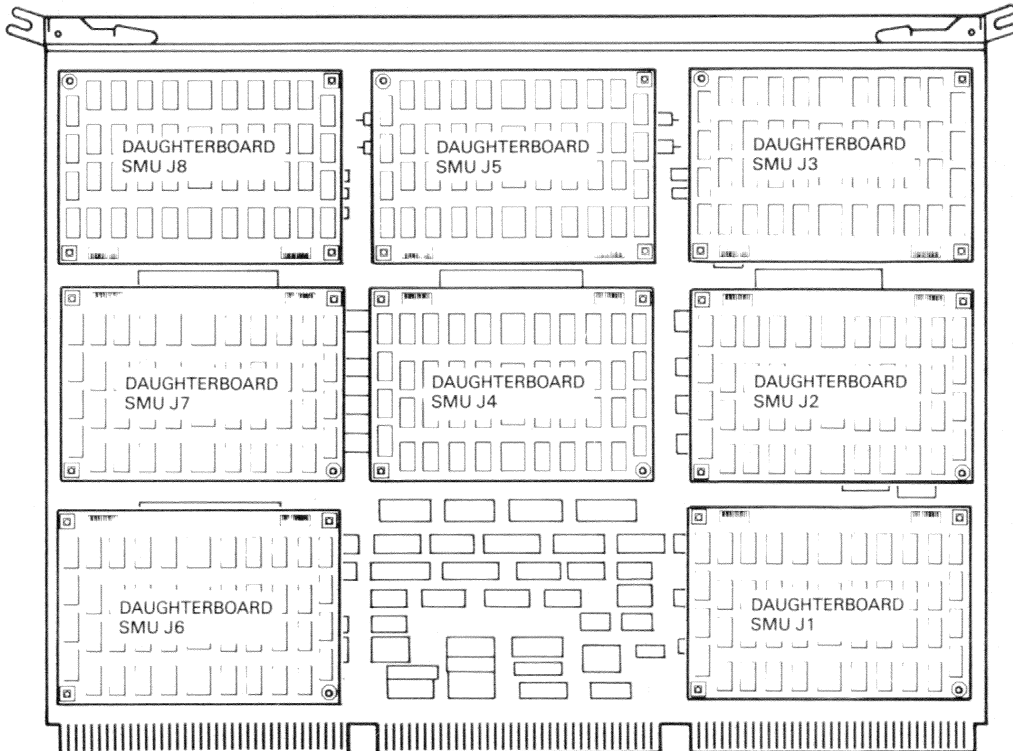

SHR0314-86

Figure 7-1 MS88-CA Module (Component Side)

The width of a bank is 39 bits (longword of 32 data bits plus 7 ECC check bits). Each daughterboard pair spans 39 bits. Data bits <38:20> are always on one daughterboard and data bits <18:00> are on the other daughterboard of a pair. Data bit <19> is toggled between a pair of daughterboards and, to isolate the source of bit <19>, you need address bit <22>.

For SBES/CRDs, the first step in isolating the failing component is to determine the failing data bit. Decode the ECC syndrome, which is in MEMORY CSR 2 <06:00>. A translation of the ECC syndrome to the failing data bit is shown below. For example, a syndrome of 75(X) indicates that data bit <26> is faulty.

```
ECC SYNDROME (MSB) 8210000 77777777666666665555555533333333 1
(HEX)             (LSB) 0008421 FCA96530EDB87421EDB87421EDB87421 3

DATA BIT          CCCCCC 33222222222211111111100000000000 BAD
                  318421T 10987654321098765432109876543210 DATA
                  26
```

Check bits <C32:CT> are analogous to data bits <38:32>. For example, check bit <C2> can also be referred to as data bit <34>.

Once you identify the failing bit, next determine the bank number from the word count field of MEMORY CSR 1 <31:30>. If data bit <19> is faulty, you also need memory address bit <22> from MEMORY CSR 1 <22>. After gathering this data, use Table 7-2 to identify the failing SMU.

Table 7-2 Failing SMU Identification

Word Count Bank Number	MEMORY CSR 1 <31:30>	<22>	Data Bit(s) from CSR 2 <06:00>	Source SMU (Daughterboard)
Bank 0	00	X	<18:00>	J2
	00	X	<38:20>	J1
	00	0	<19>	J1
	00	1	<19>	J2
Bank 1	01	X	<18:00>	J5
	01	X	<38:20>	J3
	01	0	<19>	J3
	01	1	<19>	J5
Bank 2	10	X	<18:00>	J7
	10	X	<38:20>	J6
	10	0	<19>	J6
	10	1	<19>	J7
Bank 3	11	X	<18:00>	J4
	11	X	<38:20>	J8
	11	0	<19>	J8
	11	1	<19>	J4

Finally, a memory bank in a daughterboard pair has four sub-banks. A sub-bank can be thought of as a quarter-bank that transverses a daughterboard pair. These sub-banks are selected via address bits <23:22> as shown in Table 7-3. With this information, you can isolate an SBE to a failing DRAM.

Figures 7-2 and 7-3 show address and module diagrams of the addressing attributes of the MS88-CA. Contiguous memory access reads four longwords (one longword from each of banks 0 through 3) simultaneously and cycles through a single sub-bank, followed by the other three sub-banks in sequence.

Module interleaving is not considered in this example. On a typical system with more than one module, interleaving is performed by the decode RAMs to allow faster access on 8-longword transfers.

Bank size = 156 DRAMS X 256 Kbytes = 4 Mbytes = 2 daughterboards.

Sub-bank size = 39 DRAMS X 256 Kbytes = 1 Mbyte = 2048 VMS pages.



Table 7-3 Sub-Bank/Address Bit Data

Low Data SMU					High Data SMU				
Data Bit	MEMORY 11	CSR 1 10	<23:22> 01 00		Data Bit	MEMORY 11	CSR 1 10	<23:22> 01 00	
0	E137	E135	E3	E1	20	E135	E137	E1	E3
1	E138	E136	E4	E2	21	E136	E138	E2	E4
2	E133	E131	E7	E5	22	E131	E133	E5	E7
3	E134	E132	E8	E6	23	E132	E134	E6	E8
4	E129	E127	E11	E9	24	E127	E129	E9	E11
5	E130	E128	E12	E10	25	E128	E130	E10	E12
6	E125	E123	E15	E13	26	E123	E125	E13	E15
7	E126	E124	E16	E14	27	E124	E126	E14	E16
8	E122	E120	E20	E18	28	E120	E122	E18	E20
9	E118	E17	E27	E25	29	E17	E118	E25	E27
10	E119	E117	E28	E26	30	E117	E119	E26	E28
11	E115	E113	E31	E29	31	E113	E115	E29	E31
12	E116	E114	E32	E30	32	E114	E116	E30	E32
13	E111	E109	E35	E3	33	E109	E111	E33	E35
14	E112	E110	E36	E34	34	E110	E112	E34	E36
15	E107	E105	E39	E37	35	E105	E107	E37	E39
16	E108	E106	E40	E38	36	E106	E108	E38	E40
17	E103	E101	E43	E41	37	E101	E103	E41	E43
18	E104	E102	E44	E42	38	E102	E104	E42	E44
19	E121	--	E19	--	19	--	E121	--	E19

Address bits <21:00> select the byte address within the sub-bank.

For the total of four sub-banks, address bits <23:22> select the sub-bank.

Board size = 4 sub-banks = 32768 VMS pages.

In Figure 7-3, the a sample sub-bank (bank 3, sub-bank 2) is denoted by the . A sample bank (bank 1) is denoted by . A sample daughterboard is denoted by .

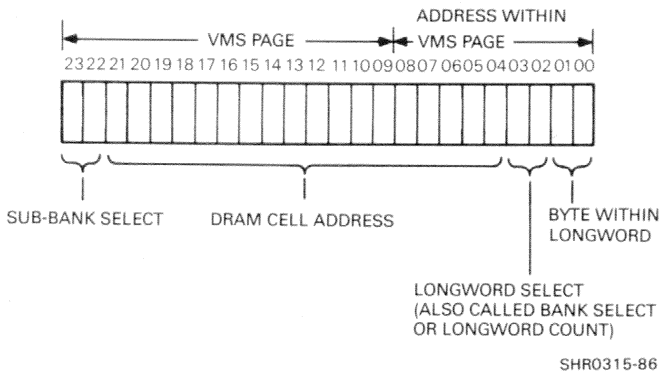

Figure 7-2 MS88-CA Address Bit Allocation (VMS)

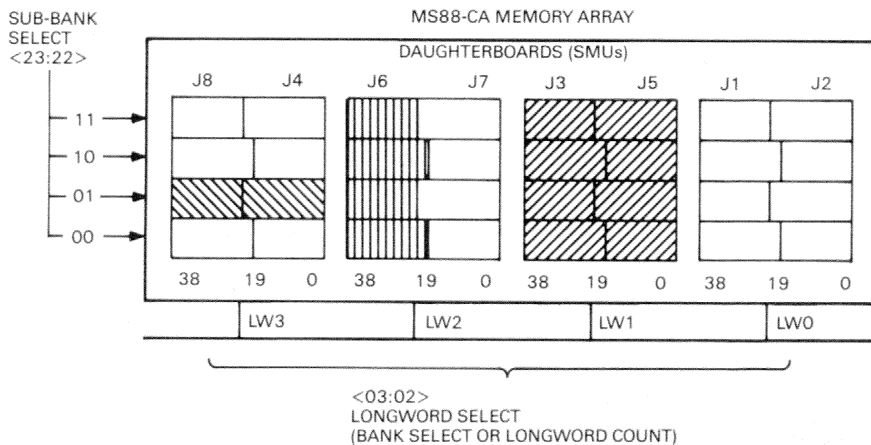
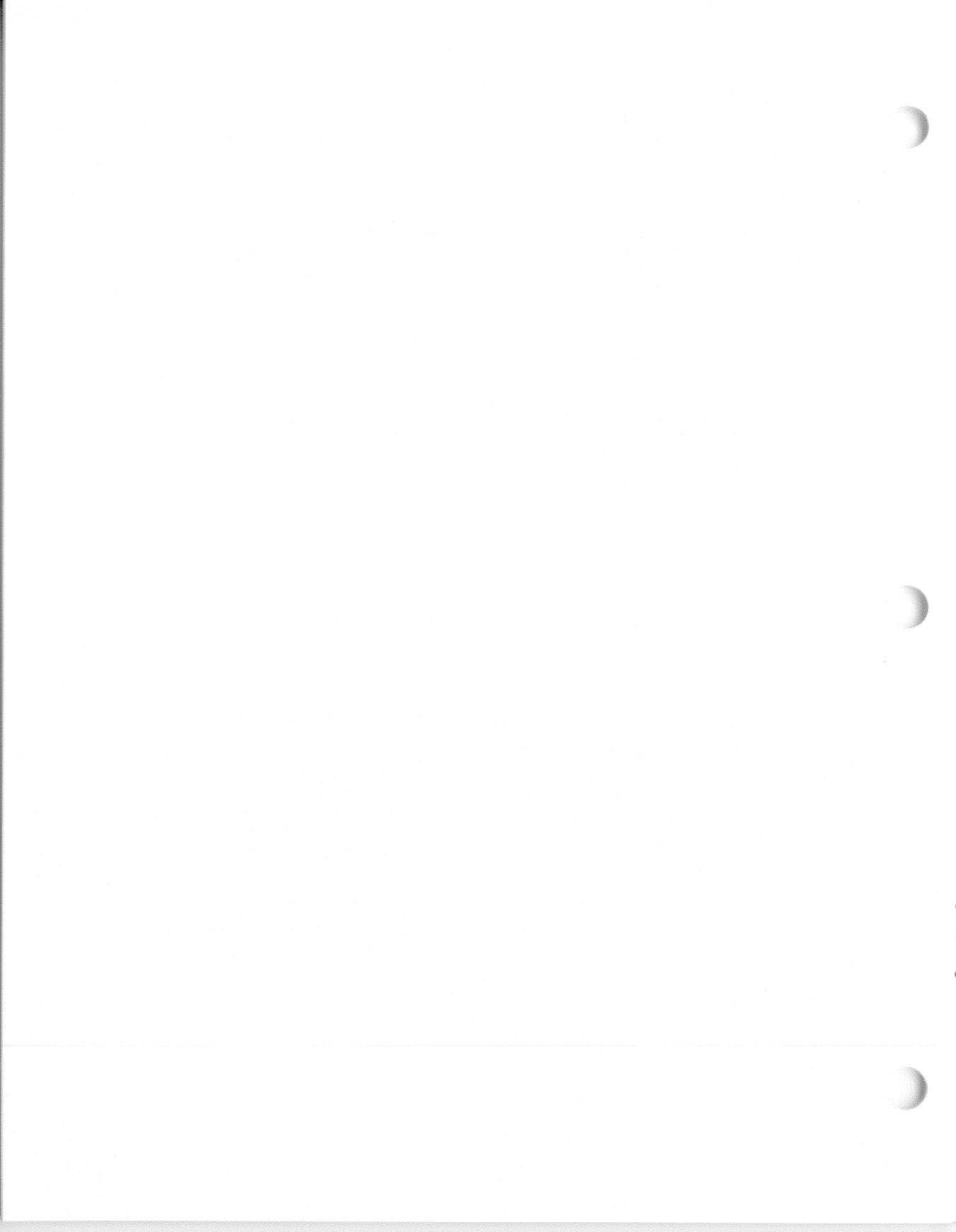

Figure 7-3 MS88-CA Functional Diagram



## GLOSSARY

**Bank** -- By design, the MS88 modules access 4 contiguous longword locations simultaneously, addressing a total of 156 DRAMs. These four longwords are labeled as longword 0 through longword 3. A bank is defined as those DRAMs that contain all addresses of a given longword on a module. For example, on the 4-Mbyte MS88-AA, bank 1 is the 39 DRAMs that provide storage for longword 1.

On the MS88-CA, the size of the bank is four times larger than on the MS88-AA. The layout of the MS88-CA has each of the four banks on two daughterboards.

**CRD (corrected read data)** -- The VMS term for a single-bit error that occurs in the memory subsystem. This error occurs during the read portion of a memory cycle and the ECC logic corrects the data on the fly, hence the name.

**Daughterboard** -- An alternate name for the small 7.6 cm X 12.7 cm (3 in X 5 in) module (PN 54-16500-BA) that mounts on the motherboard (PN L0115-00).

**DBE (double-bit error)** -- Occurs when the hardware (ECC logic) detects that two or more bits within a given longword are in error. This error cannot be corrected by the hardware.

**ERF (error reporting facility)** -- Run under VMS, ERF provides the bit-to-text translation of the system error log. It is invoked by VMS with the ANALYZE/ERROR DCL command. ERF is a useful tool that provides Field Service with the information necessary to make repairs.

**FRU (field replaceable unit)** -- The part in a system that is replaced to correct a fault. The Field Service engineer uses diagnostics to isolate a system fault to the failing FRU. The FRU for the MS88-AA is the entire module; the FRUs for the MS88-CA are the daughterboards on the module.

**L0115-00** -- The part number of the MS88-CA motherboard. It includes the extended hex motherboard without daughterboards installed. This number is used by Field Service to order spares.

**L0116-00** -- The part number of the MS88-AA. This module is the original used in the VAX 8500/8550 and VAX 8700/8800 systems. This part number is used by Field Service to order spares.

**Motherboard** -- The extended hex module (PN L0115-00) upon which eight smaller modules are mounted.

**MR16** -- Also referred to as MAR16. The design name given to the MS88-CA and used by the product development team.

**MS85-HA** -- The part number of the 32-Mbyte upgrade kit for VAX 8500/8550 systems. The kit includes a wide-spaced, 5-slot backplane and two 16-Mbyte MS88-CAs.

**MS88-AA** -- The 4-Mbyte memory array module.

**MS88-CA** -- The 16-Mbyte memory array module. This module includes the motherboard (PN L0115-00) plus eight daughterboards (PN 54-16500-BA).

**MS88-HA** -- The part number of the 32-Mbyte upgrade kit for VAX 8700/8800 systems. The kit includes a wide-spaced, 8-slot backplane and two 16-Mbyte MS88-CAs.

**RDS (read data substitute)** -- The VMS term for a double-bit error that is detected by the hardware in the memory subsystem.

**SBE (single-bit error)** -- An error that is the result of a single bit in error within a given longword. Because the memory is ECC protected, the hardware can correct SBEs by default.

**SMU (standard memory unit)** -- An alternate name for the daughterboard on the MS88-CA.

**Sub-Bank** -- On the MS88-CA, the DRAMs on the daughterboard pairs are divided into sub-banks. Each daughterboard pair has a total of four sub-banks. See Chapter 7 for details.

**Word Count** -- In the context of the memory array bus (MAB or NAB) and the MS88 modules, the word count is the 2-bit code that selects one longword within an octaword (which is the basic unit of transfer over the MAB). The word count is analogous to the bank and, on the MS88-CA, the word count is used to select the appropriate pair of daughterboards. Also referred to as the longword count.





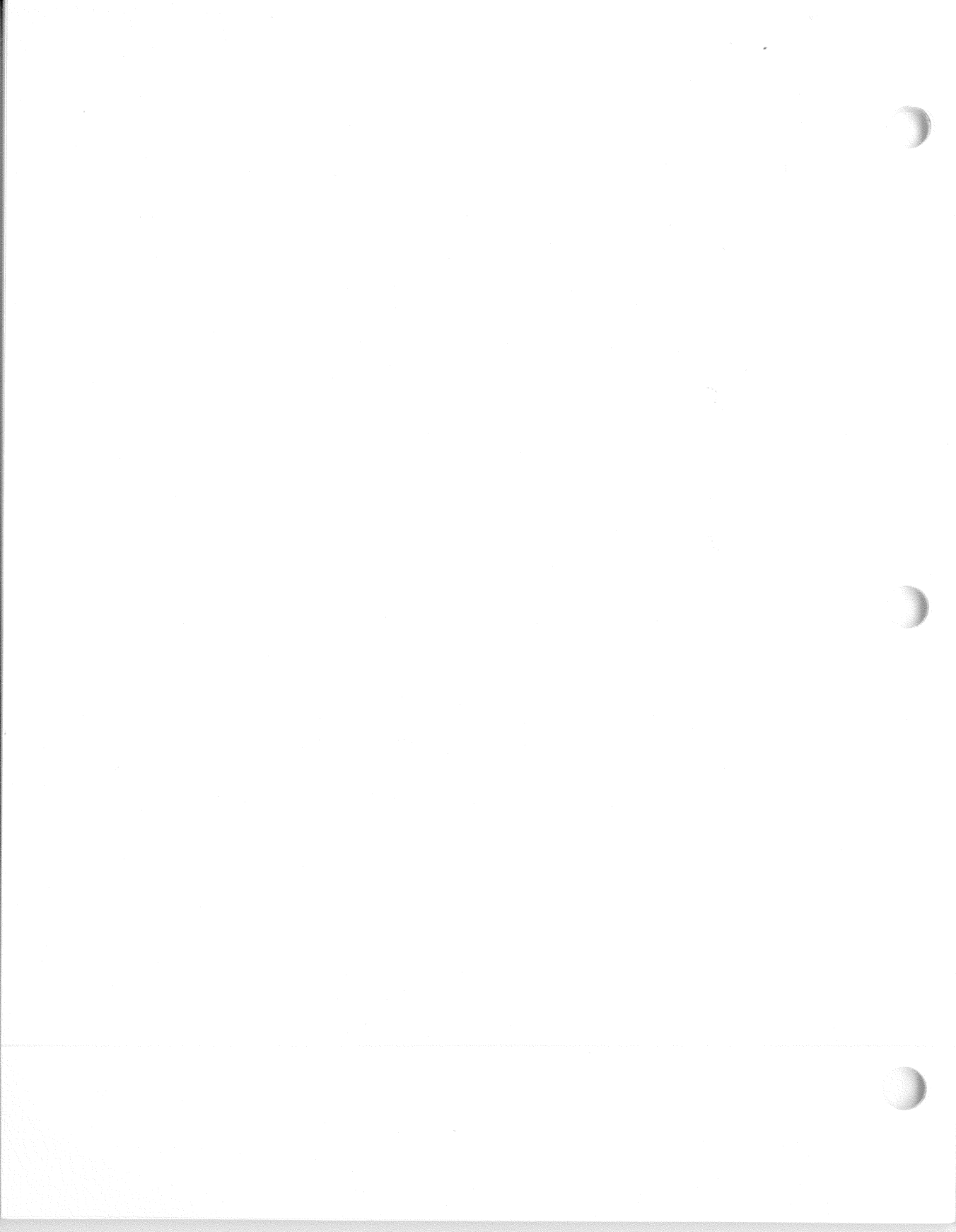

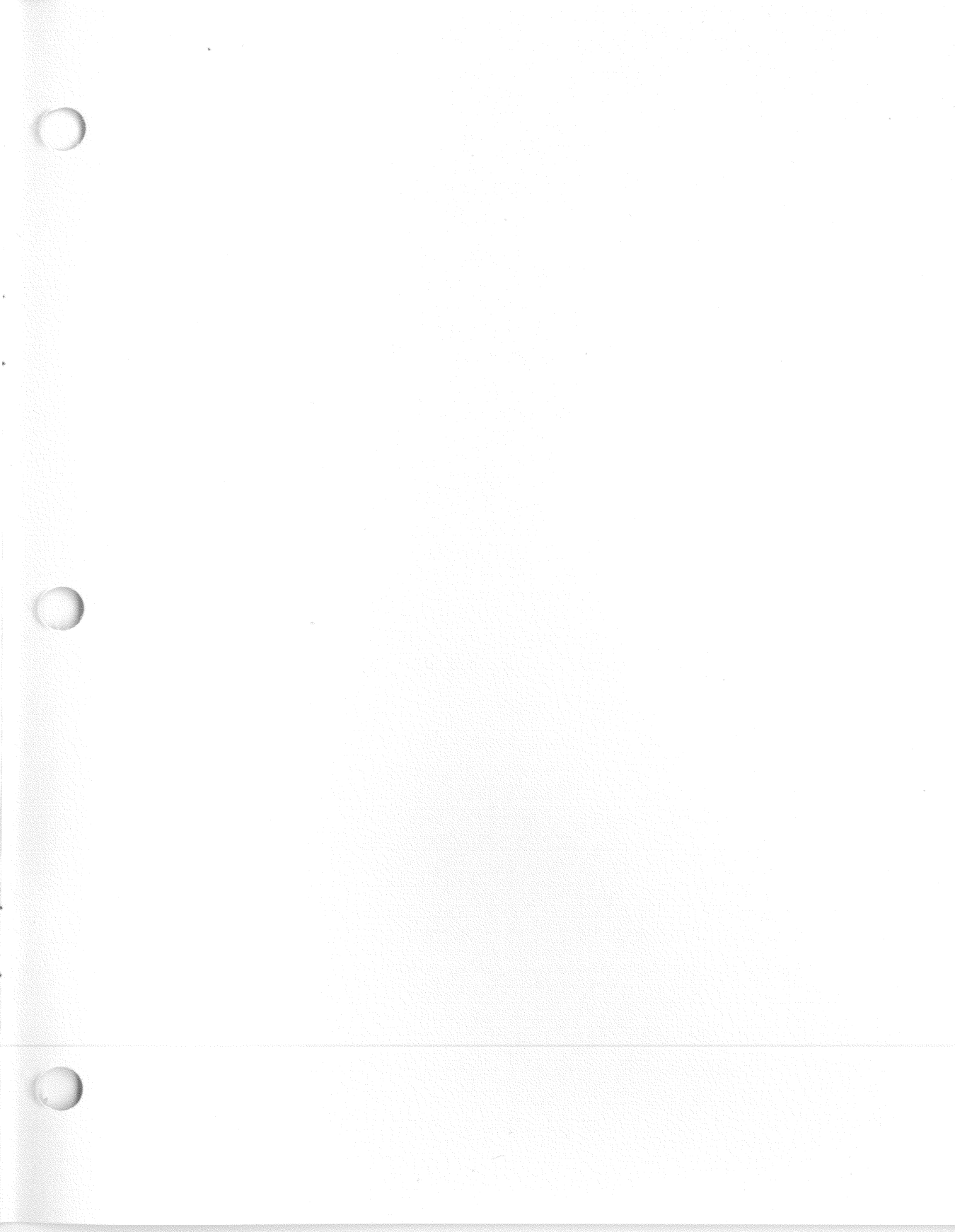

Digital Equipment Corporation • Shrewsbury, MA 01545