

Industrial Micro Systems Model 490

Installation and Checkout

Installation and checkout of the CMD module should be performed following the procedures in the Control Data Corporation Cartridge Module Drive Hardware Maintenance Manual #75888415, Section 3.1.

In section 3.10 preparation for use, the sector number option switches should be set for 32 sector per revolution.

In addition the "A" cable terminator located on the electronics module at I/O J2 should be replaced with the Industrial Micro Systems Model 520 Terminator.

60 PIN 26 PIN

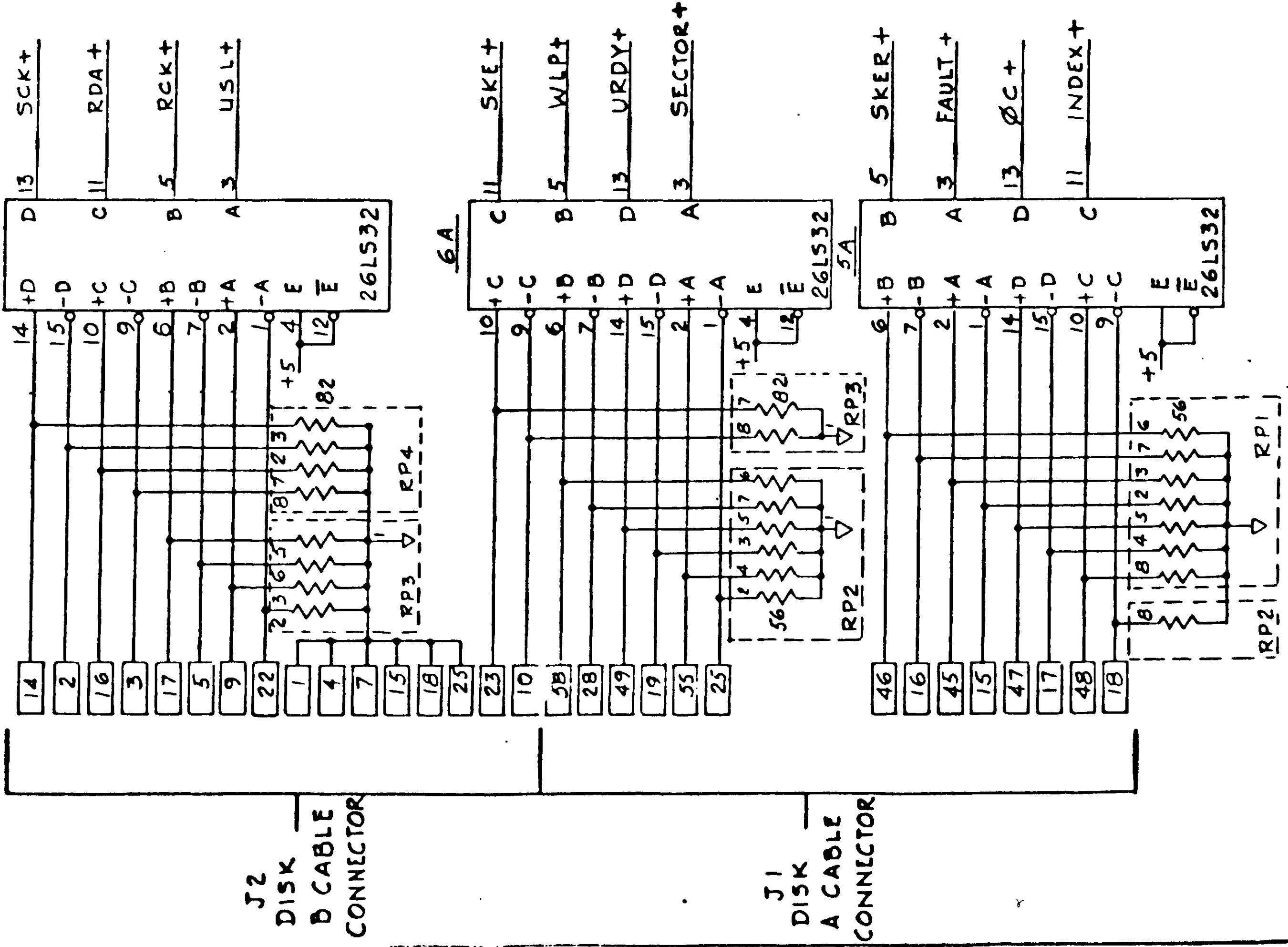
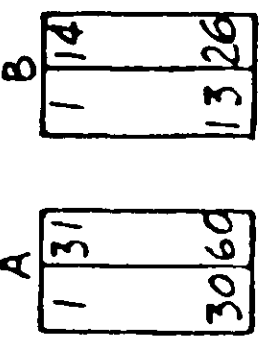

J2  
DISK  
B CABLE  
CONNECTOR

J1  
DISK  
A CABLE  
CONNECTOR

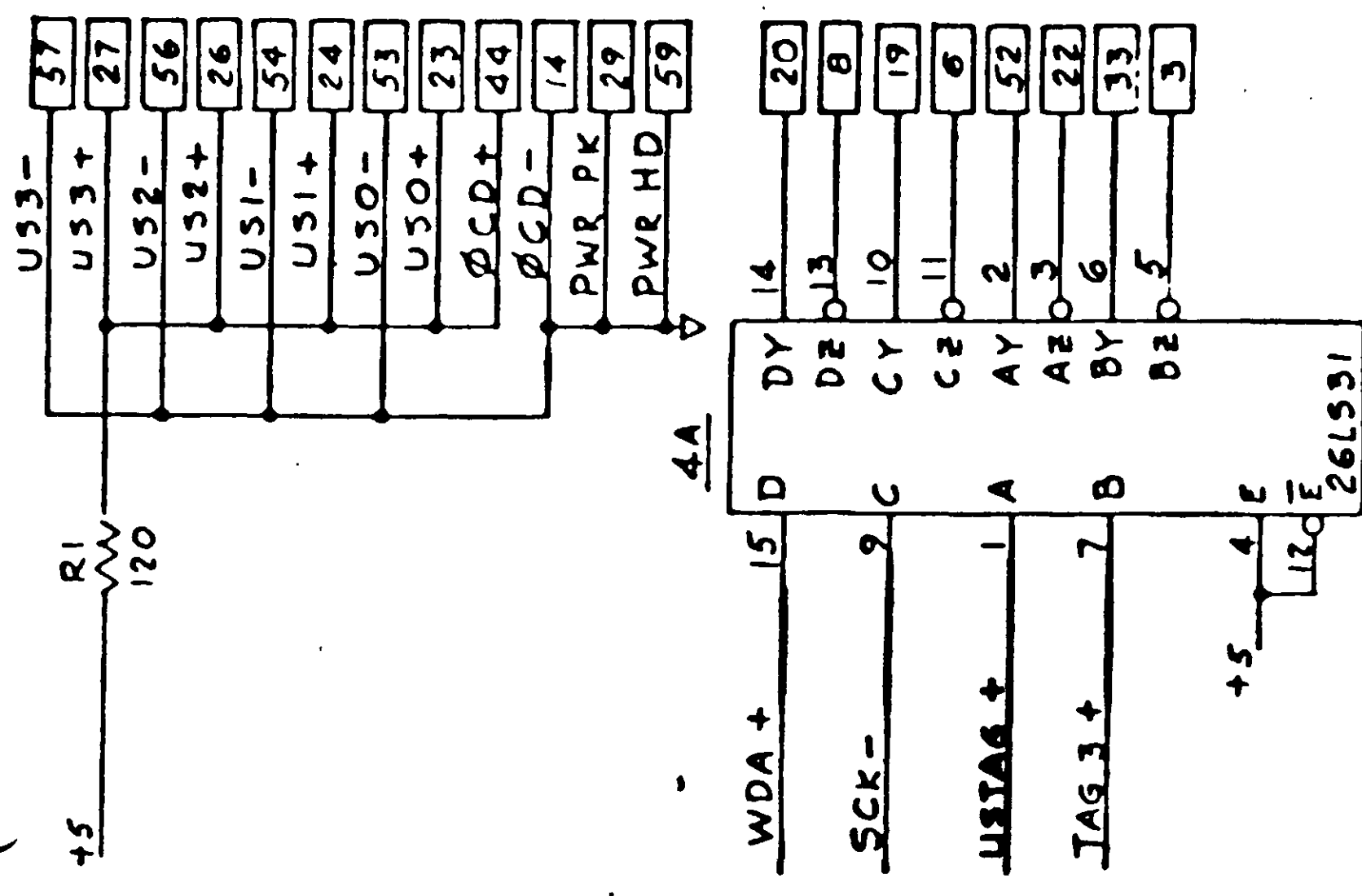

J1  
DISK  
A CABLE  
CONNECTOR

J2  
DISK  
B CABLE  
CONNECTOR

J1  
DISK  
A CABLE  
CONNECTOR

CONTINUED ON  
SHEET 2

INDUSTRIAL MICRO SYSTEMS

DATE: 1-30-80

DESIGNED BY: [ ]

DRAWN BY: E.D.W.

REVISED: 6-20-80

DISK CONTROLLER

L00490

SH. 1 OF 11

CONTINUED FROM  
PAGE 5 ET 3

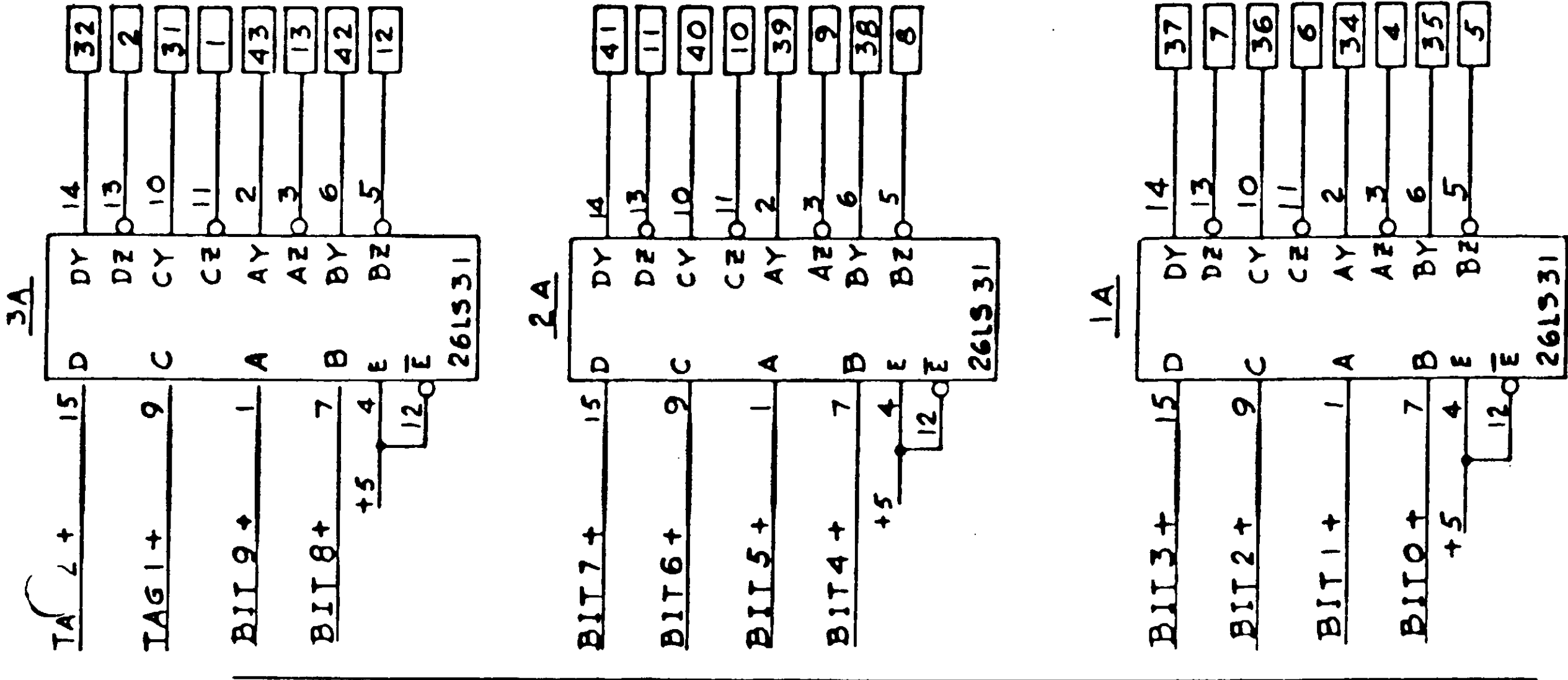

J1  
DISK  
A CABLE  
CONNECTOR

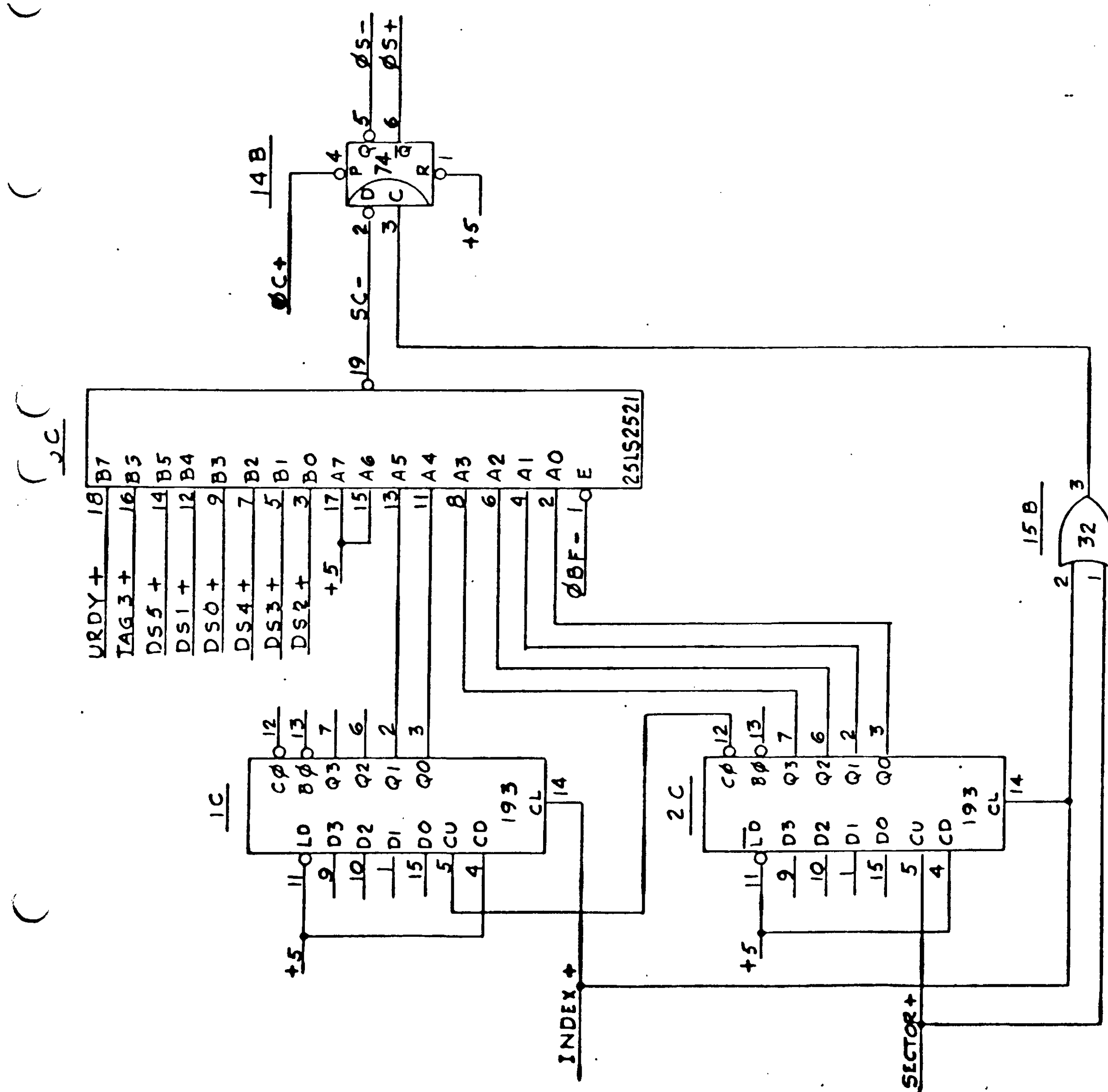

INDUSTRIAL MICRO SYSTEMS  
 MODEL: 1-30-80  
 DISK CONTROLLER  
 LCC 490  
 REV. 2 DW  
 6-20-80  
 SH 2 or 11



DEVICE CODE  
90-97

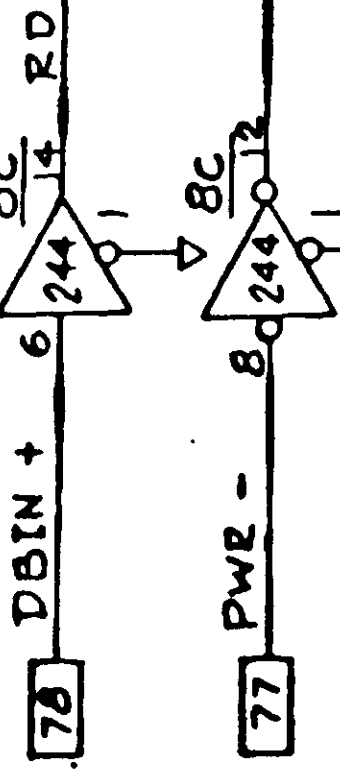
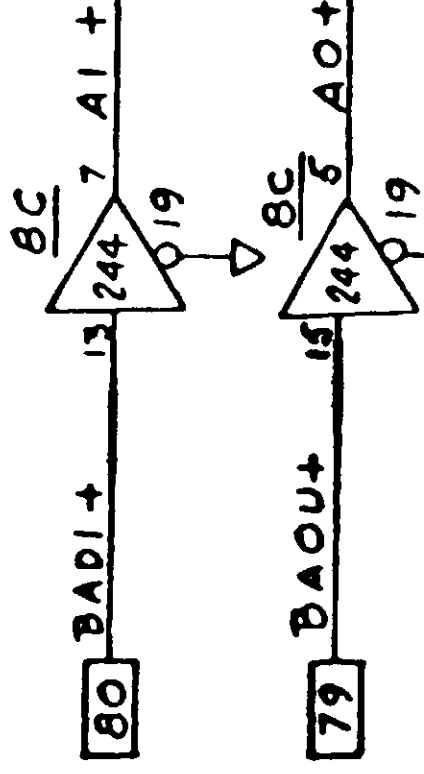
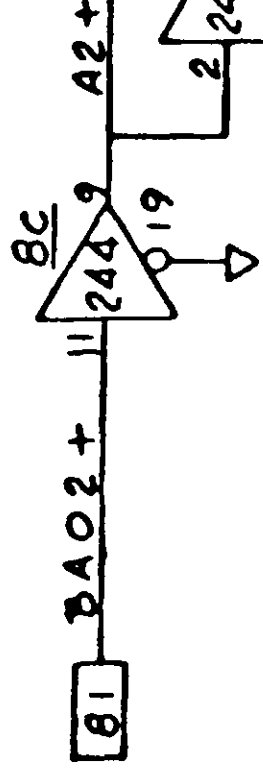
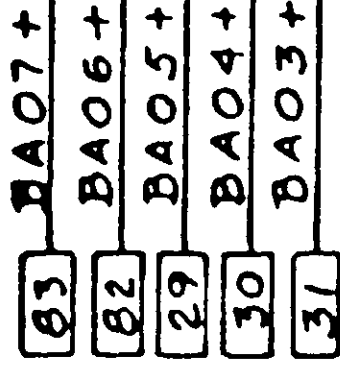
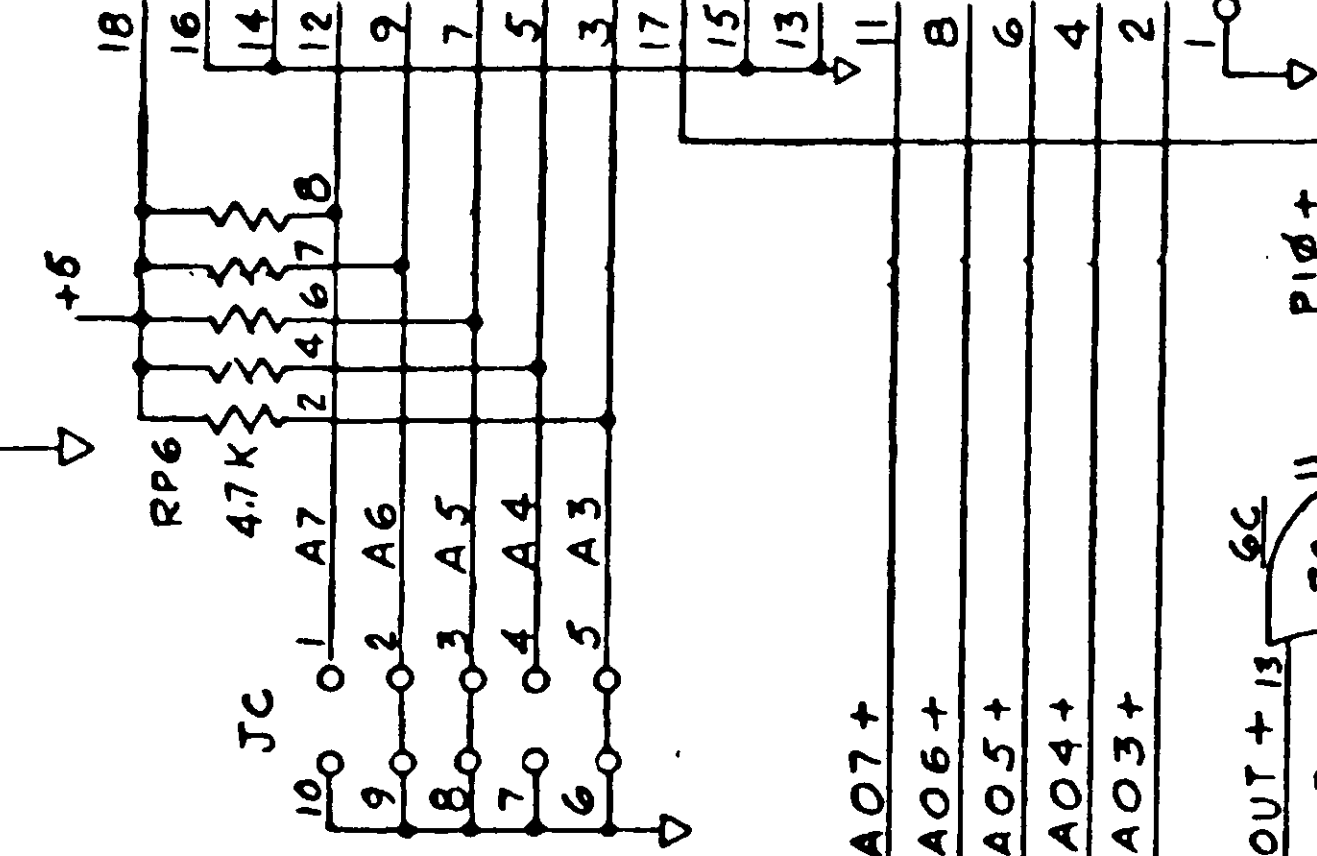
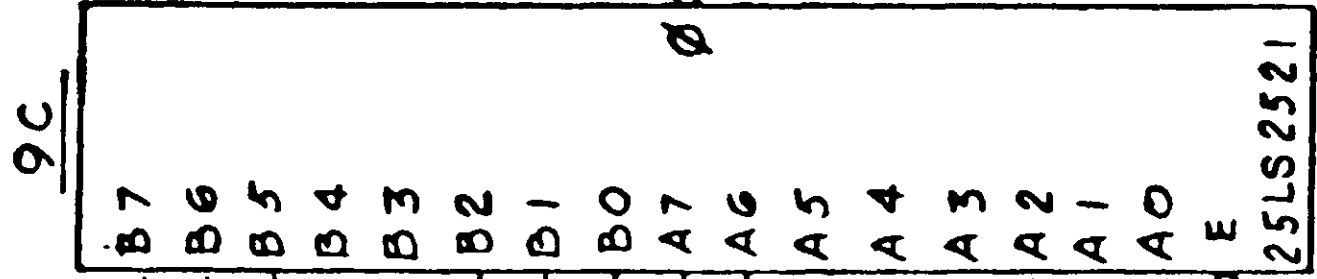

IUAL

CS03-

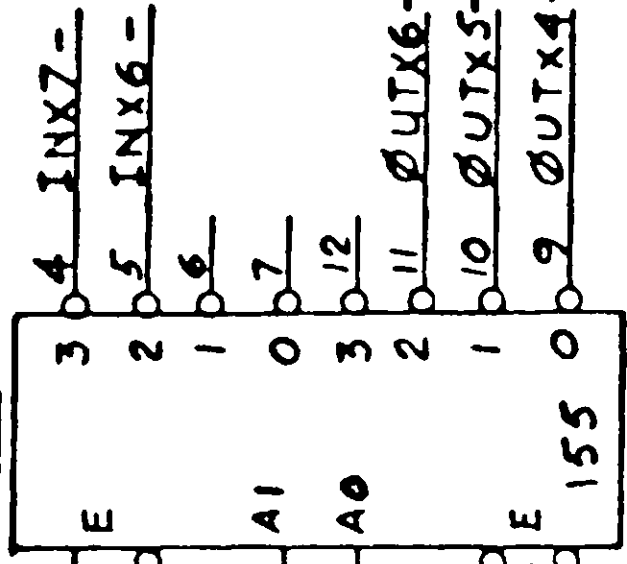

RD-

WR-

INDUSTRIAL MICRO SYSTEMS  
 DATE: 1-30-80  
 DRAWN BY: R.D.W.  
 CHECKED BY: G-20-80  
 L00490

CE	RX	
0	0	B→A
0	1	A→B
1	X	Σ

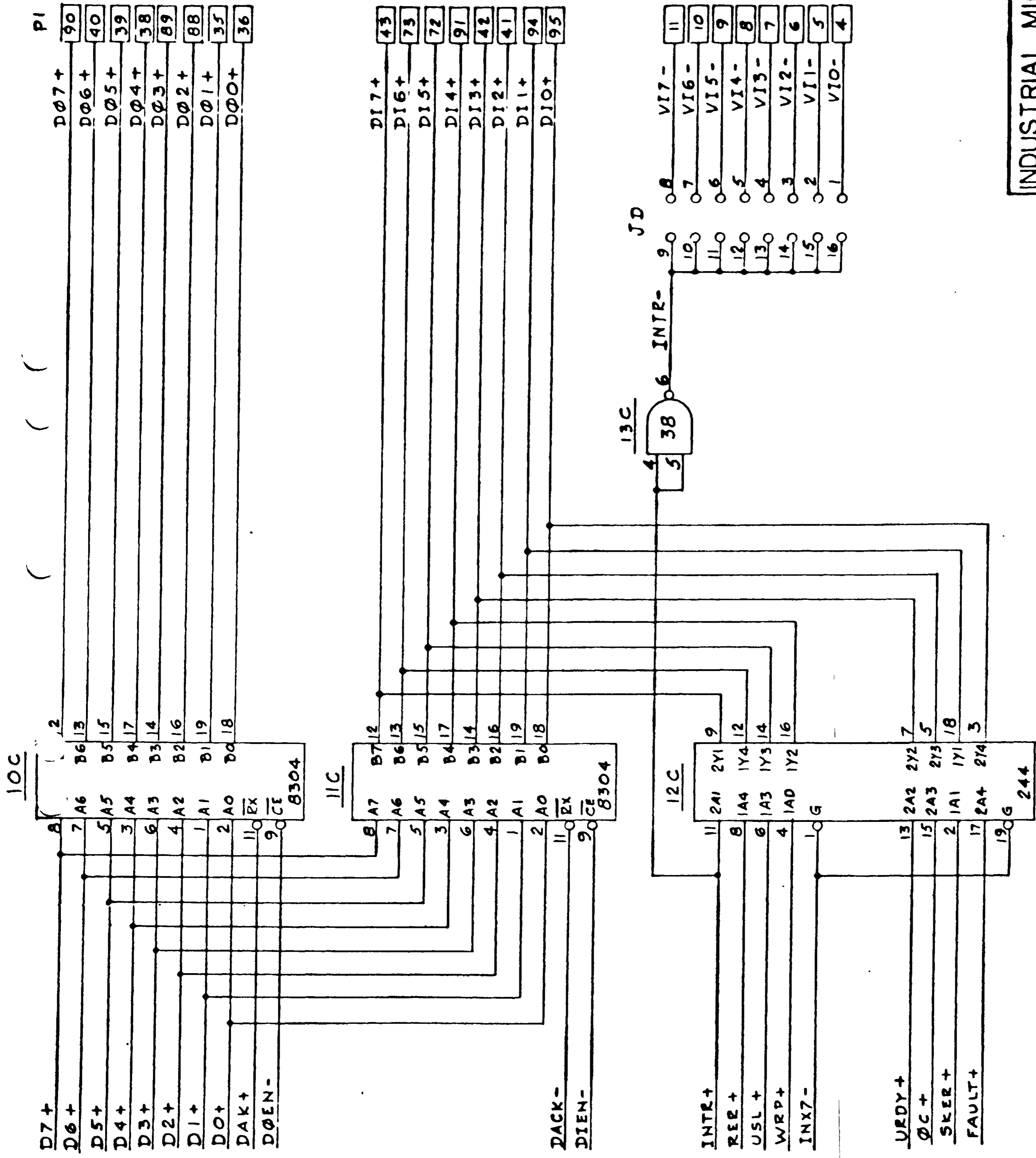

INDUSTRIAL MICRO SYSTEMS  
 DATE: 2-5-80  
 DRAWING NO.: 6-20-80  
 DISK CONTROLLER  
 100200

3408-3205 WN

16 PIN NO. SIGNATORS

J3

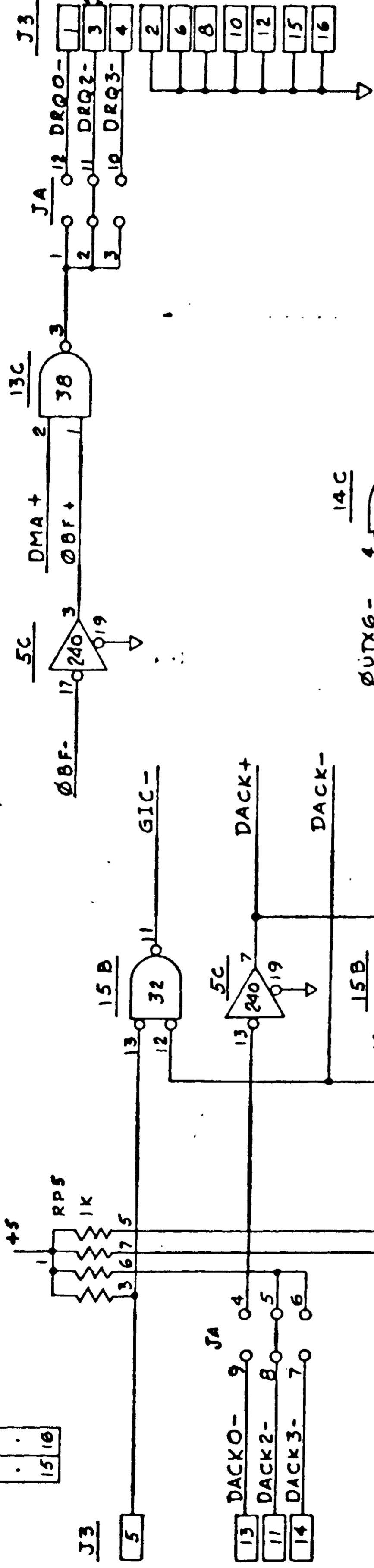
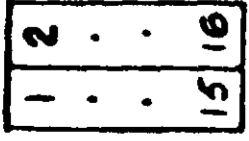

INDUSTRIAL MICRO SYSTEMS

REV 1-31-80

DISK CONTROLLER

100000

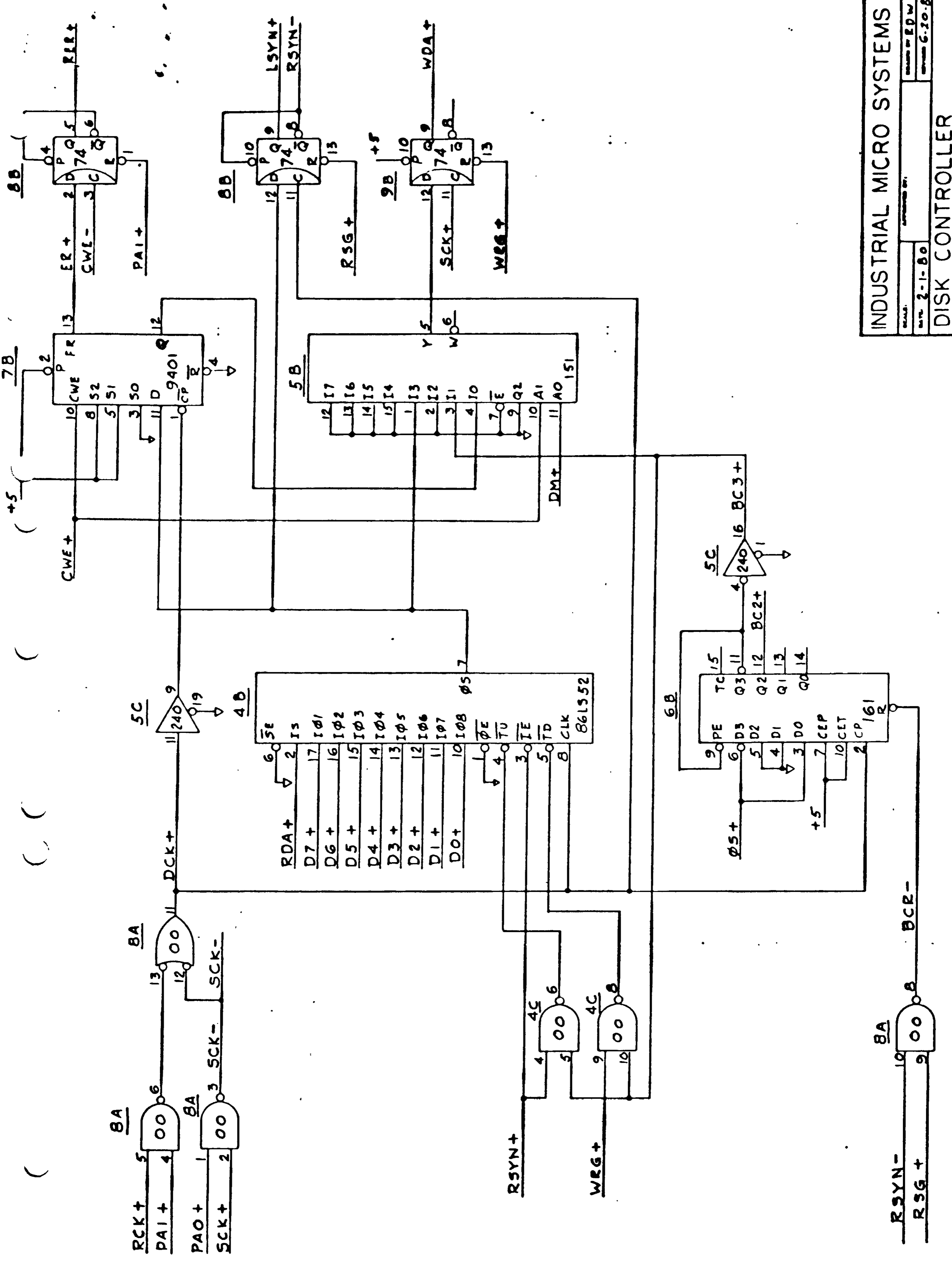

INDUSTRIAL MICRO SYSTEMS  
 MODEL 2-1-80  
 DISK CONTROLLER  
 L00490  
 REVISED 6-20-80  
 CU 6 0 1 1

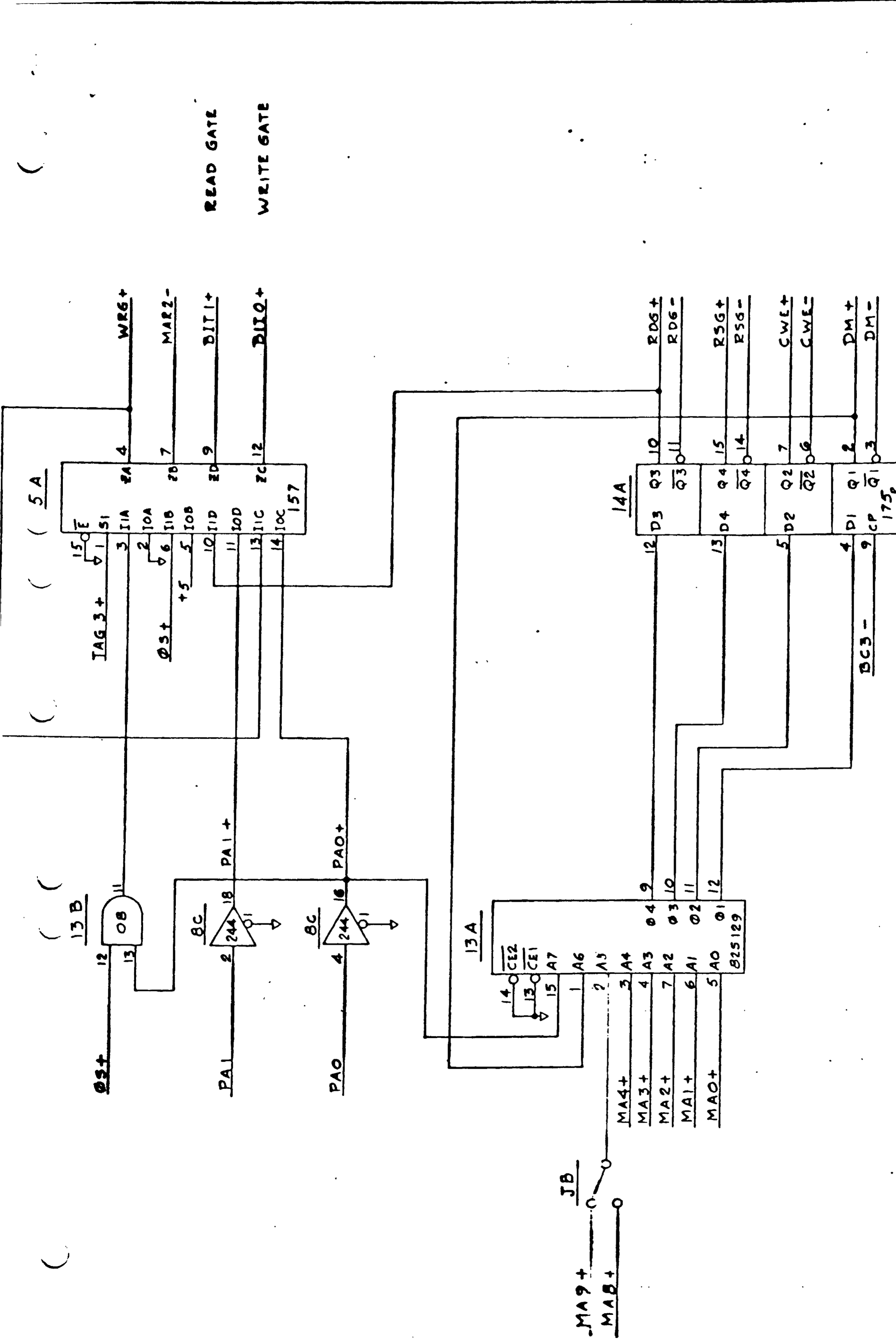

INDUSTRIAL MICRO SYSTEMS  
 DRAWN BY: E.D.W.  
 DATE: 2-4-80  
 DISK CONTROLLER  
 L00490  
 SHEET NO. 54 OF 11



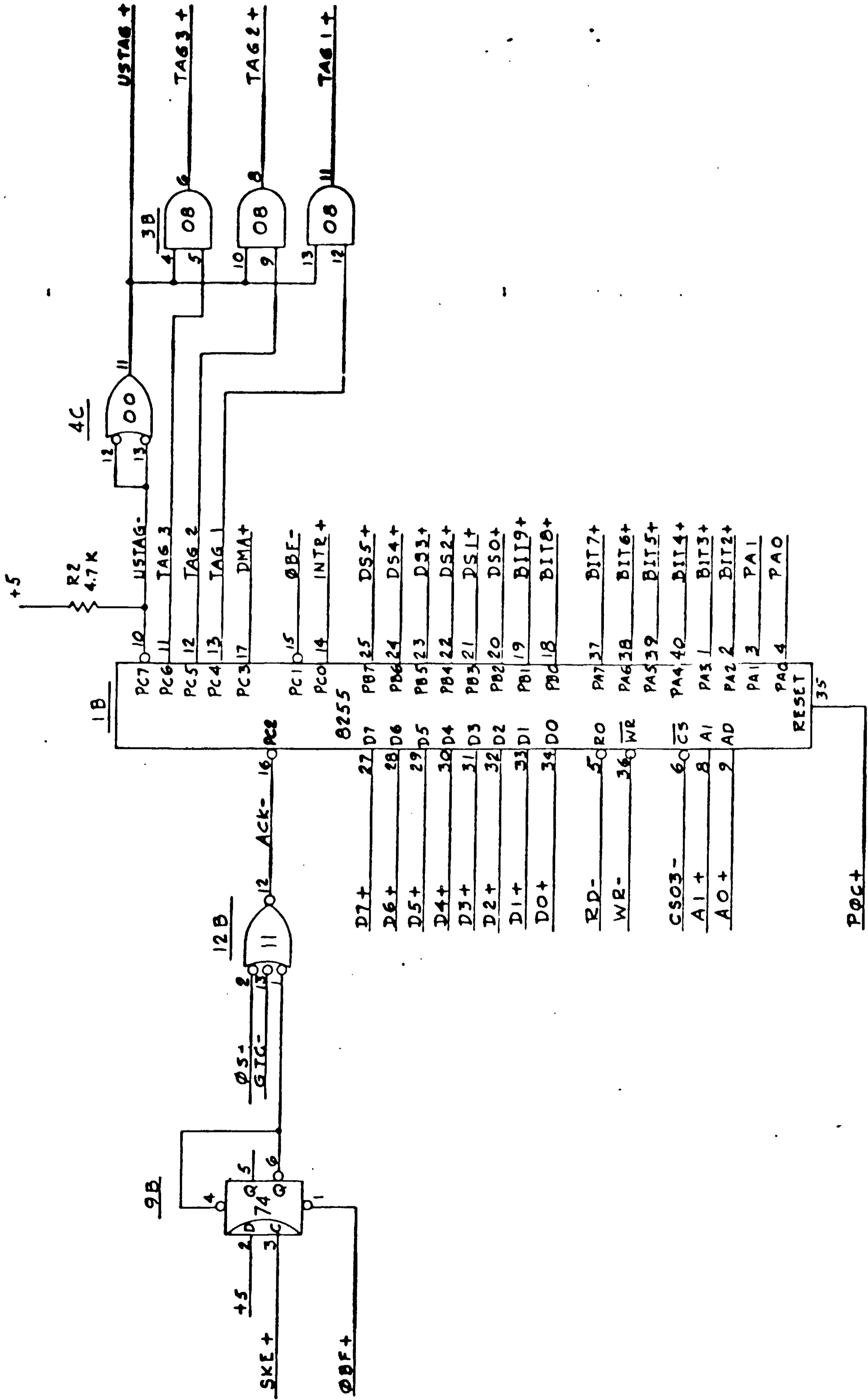

VCC	26
GND	7

INDUSTRIAL MICRO SYSTEMS  
 PART NO. 8-4-80  
 DISK CONTROLLER  
 100490  
 5 of 11

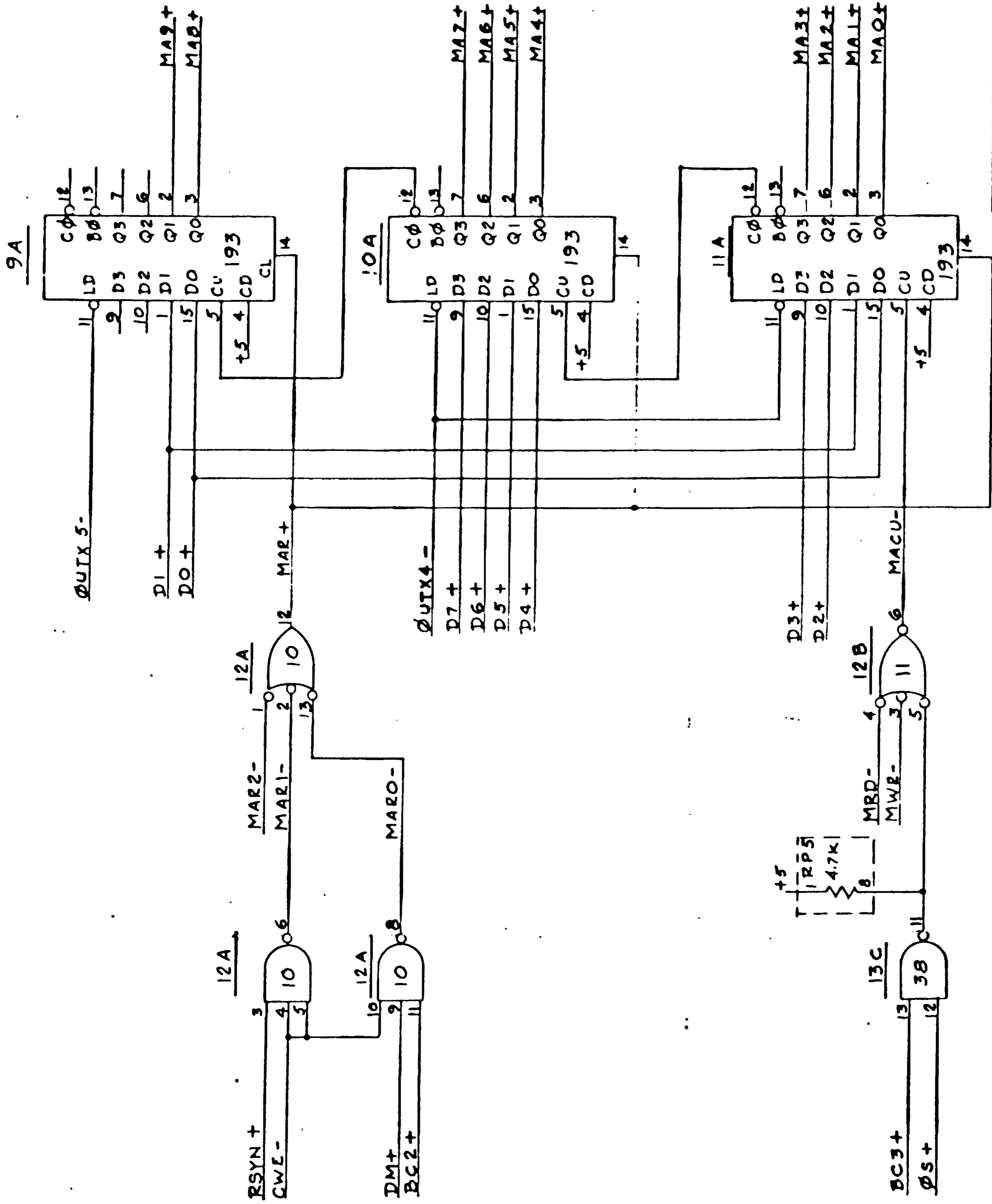

INDUSTRIAL MICRO SYSTEMS  
 DRAWN BY R.P.W.  
 DATE: 2-4-80  
 DISK CONTROLLER  
 100490  
 5 of 5

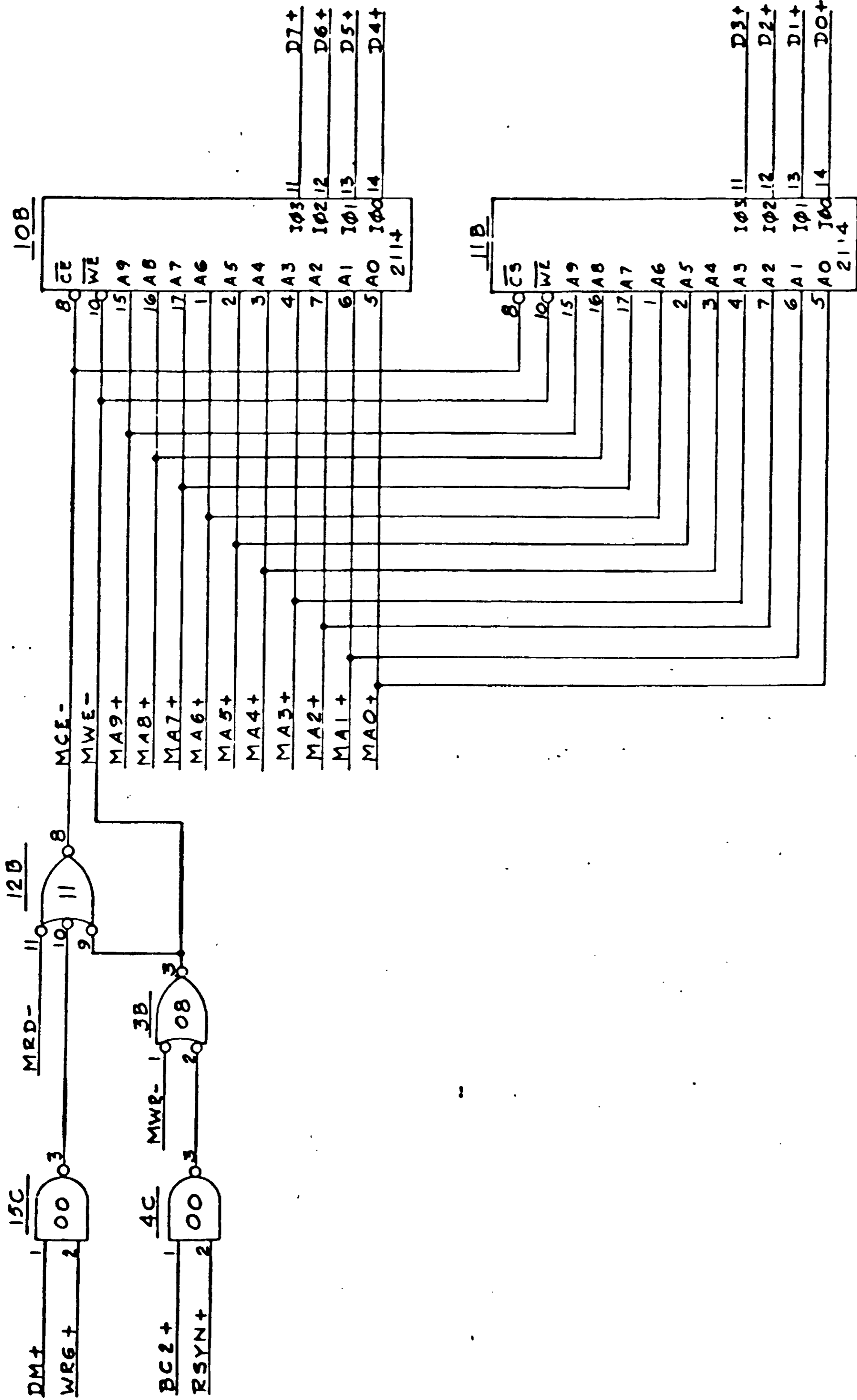

VCC	-1B
GND	-8

INDUSTRIAL MICRO SYSTEMS

REV. 2-4-80

DISK CONTROLLER

LOC490

5-10911

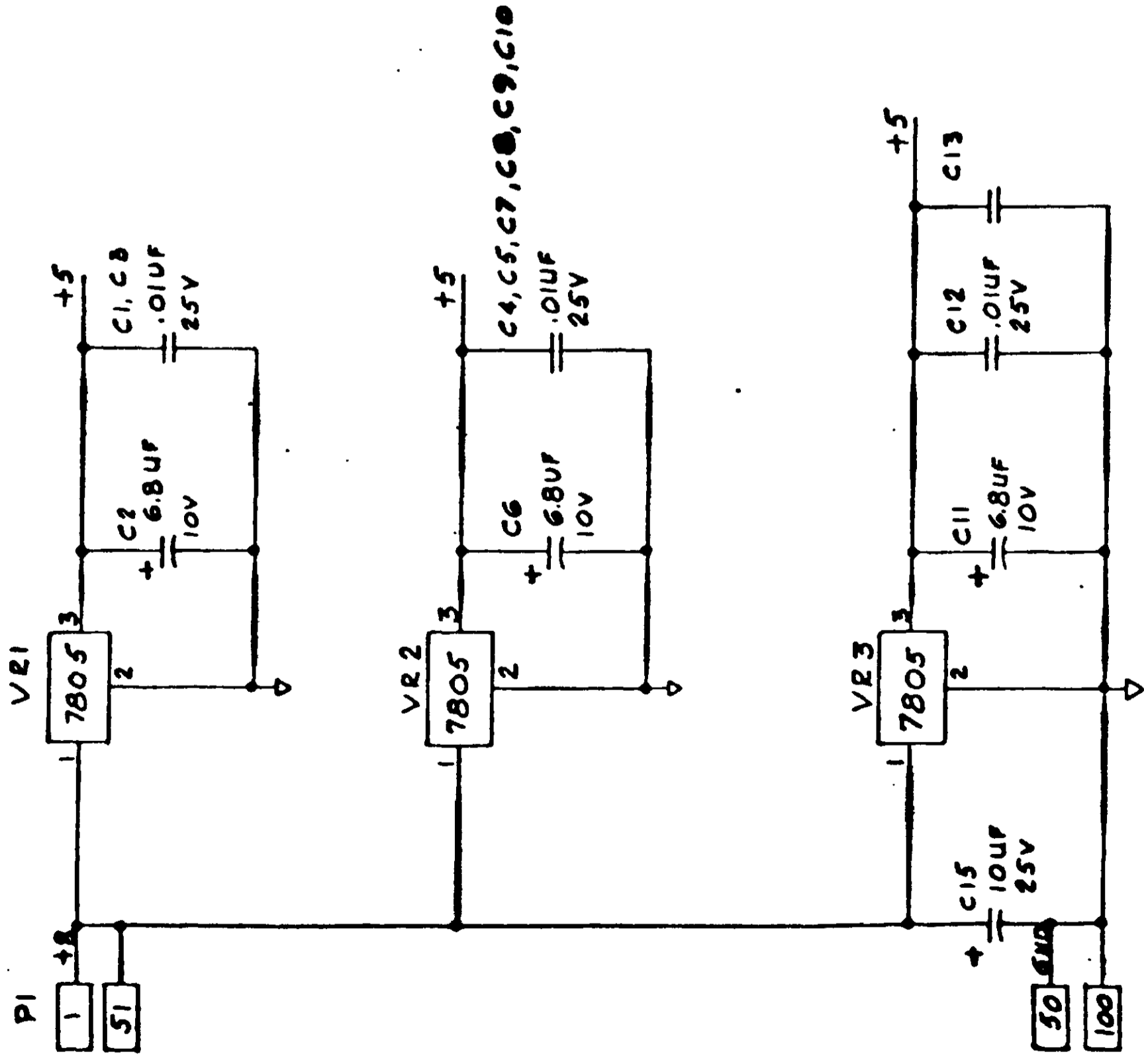

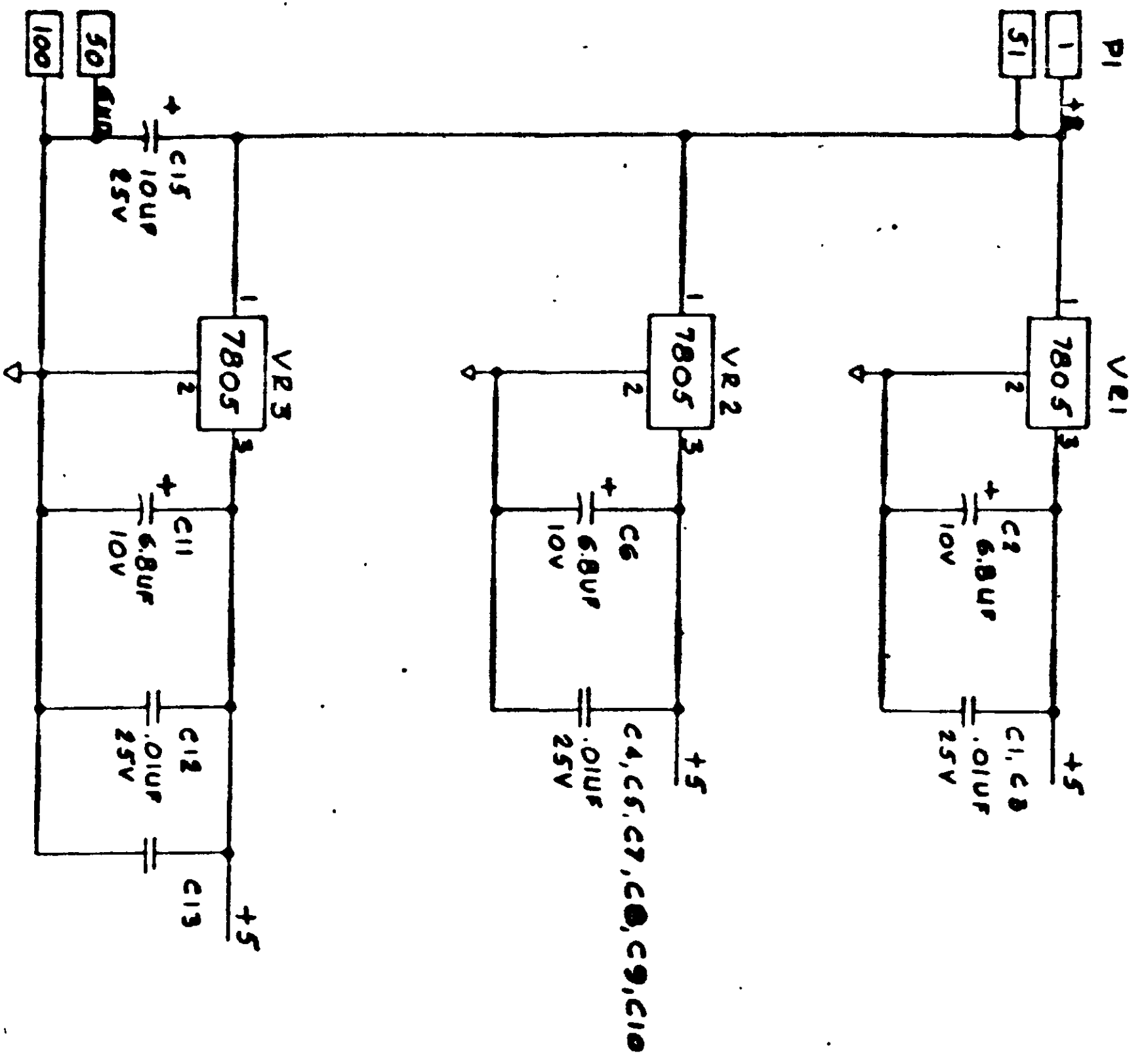

INDUSTRIAL MICRO SYSTEMS

DATE: 2-4-80

DISK CONTROLLER

100490