

**TRANSTEL  
TELEPRINTERS**

**AH-11(R)  
30 CPS  
Receive-Only  
Teleprinter**

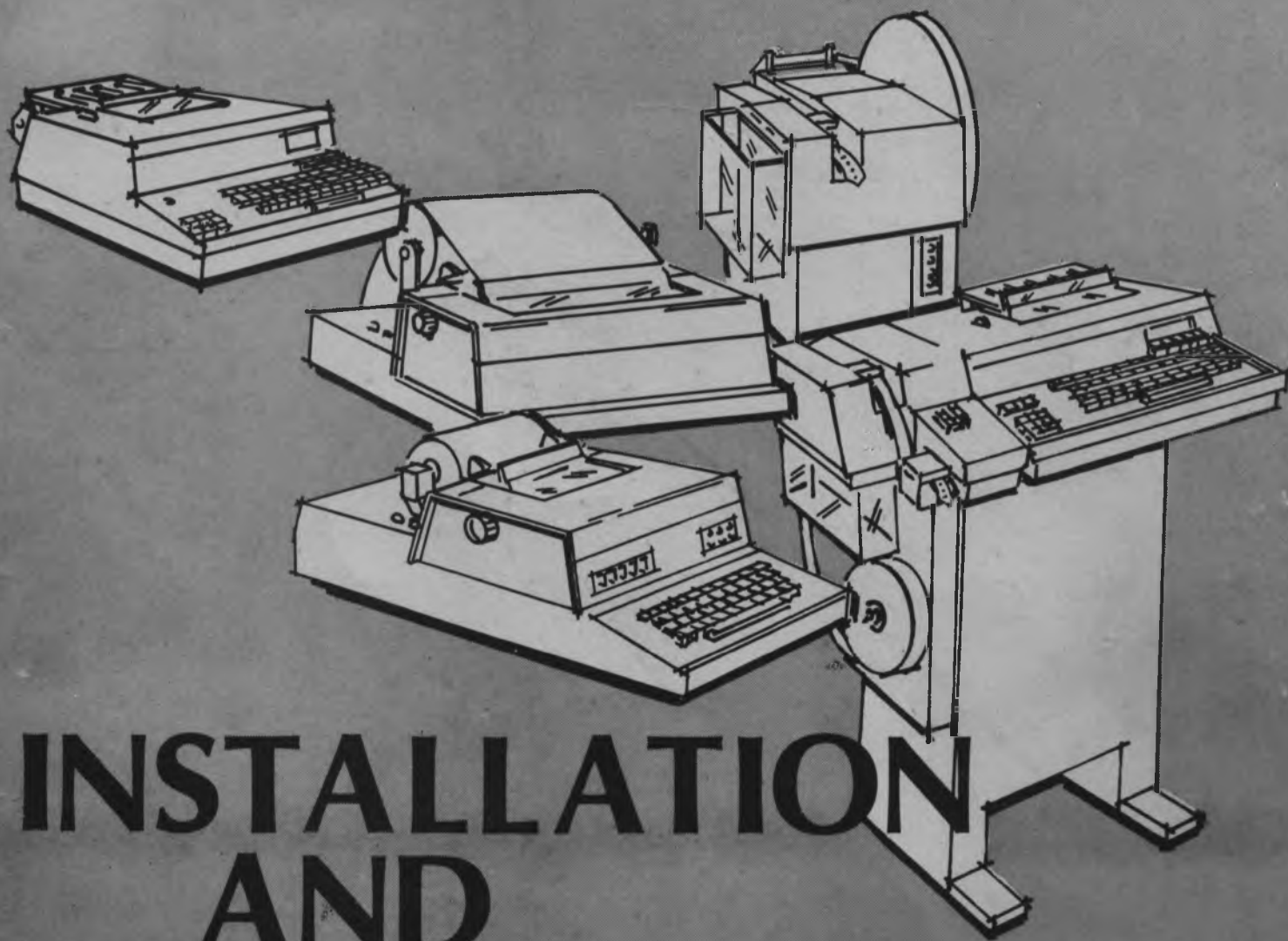

**INSTALLATION  
AND  
OPERATION  
MANUAL**



### PROPRIETARY STATEMENT

The manual contains proprietary information of Extel Corporation intended solely for the information and use of parties operating and maintaining the equipment described herein. Such proprietary information may not be used, reproduced or disclosed to any other parties or for any other purpose without the express written permission of Extel Corporation.





# AH-11R

## 30 cps Teleprinter

### INSTALLATION and OPERATION MANUAL

#### NOTE

This manual applies only to the AH-11R plain-paper teleprinter. A separate *Installation and Operation Manual, SV-162-76*, applies to the AH-11RS Sprocket Feed Teleprinter. This manual may be ordered from Transtel Communications Ltd.

CONTENTS

Section	Page
<b>1. INTRODUCTION</b>	
1-1. General .....	1-1
1-2. Principles of Operation .....	1-2
a. Character Printing and Spacing .....	1-2
b. Paper Feed Drive Mechanism .....	1-2
c. Carriage Return .....	1-3
1-3. Special Features .....	1-3
a. Special Character Fonts .....	1-3
1. Lower Case Characters .....	1-3
2. Bold Face Characters .....	1-3
3. Expanded Characters .....	1-3
b. Variable-Width Underlining .....	1-3
c. Short Lines .....	1-4
d. Auto Message .....	1-4
e. Half-Line Feed Feature .....	1-4
f. Last Character Visibility (LCV) .....	1-4
g. 96-Character Mode .....	1-4
h. Full Monitor Mode .....	1-4
1-4. Teleprinter Code Reception .....	1-4
1-5. Operating Frequencies .....	1-6
1-6. Available Options .....	1-7
a. Sensor Unit for Low Paper Alarm .....	1-7
b. Selective Calling .....	1-7
c. Paperwinder .....	1-7
d. Pedestal .....	1-7
1-7. Characteristics and Specifications .....	1-8
a. Printing Characteristics .....	1-8
b. Paper Specifications .....	1-8
c. General Specifications .....	1-8
<b>2. EQUIPMENT INSTALLATION</b>	
2-1. General .....	2-1
2-2. Unpacking and Inspection .....	2-1
2-3. Installation Location .....	2-2



	Page
<b>2-4. Controls and Indicators</b> . . . . .	2-2
a. Power ON/OFF Switch . . . . .	2-2
b. Power-ON Lamp . . . . .	2-2
c. Circuit Alarm Lamp . . . . .	2-2
d. Speed Control Switch . . . . .	2-3
<b>2-5. Power Interface</b> . . . . .	2-3
a. General . . . . .	2-3
b. Changing Operating Voltage . . . . .	2-3
<b>2-6. Signal Interface</b> . . . . .	2-4
a. Neutral/Polar/Audio Lines . . . . .	2-4
b. RS-232 (EIA) Interface . . . . .	2-5
c. Polar or EIA Interface . . . . .	2-6
<b>2-7. Programming Options</b> . . . . .	2-7
a. 7981 Series 5-Level Logic Board . . . . .	2-7
b. 7085, 7086, 7087, 7986 Series 5- /8-Level Logic Board . . . . .	2-7
<b>2-8. Internal Access</b> . . . . .	2-8
a. Teleprinter Cover Removal/Replacement . . . . .	2-8
b. Access to Printed Circuit Board Assemblies . . . . .	2-8
 <b>3. OPERATING INSTRUCTIONS</b>	
<b>3-1. General</b> . . . . .	3-1
<b>3-2. Paper Installation</b> . . . . .	3-1
a. Types of Paper . . . . .	3-1
b. Paper Loading . . . . .	3-1
c. Removal of Paper from Paperwinder . . . . .	3-3
<b>3-3. Ribbon Installation</b> . . . . .	3-4
<b>3-4. Message Removal</b> . . . . .	3-5
a. Single-Copy Paper . . . . .	3-5
b. Multi-Copy Paper . . . . .	3-5
<b>3-5. Operating Specifications</b> . . . . .	3-6
a. Line Feed Switch . . . . .	3-6
b. Speed Control Switch . . . . .	3-7
c. Special Character Fonts . . . . .	3-7
d. Half-Line Feed/Reverse Half-Line Feed . . . . .	3-7
<b>3-6. Operator-Level Maintenance</b> . . . . .	3-7



## SECTION 1 INTRODUCTION

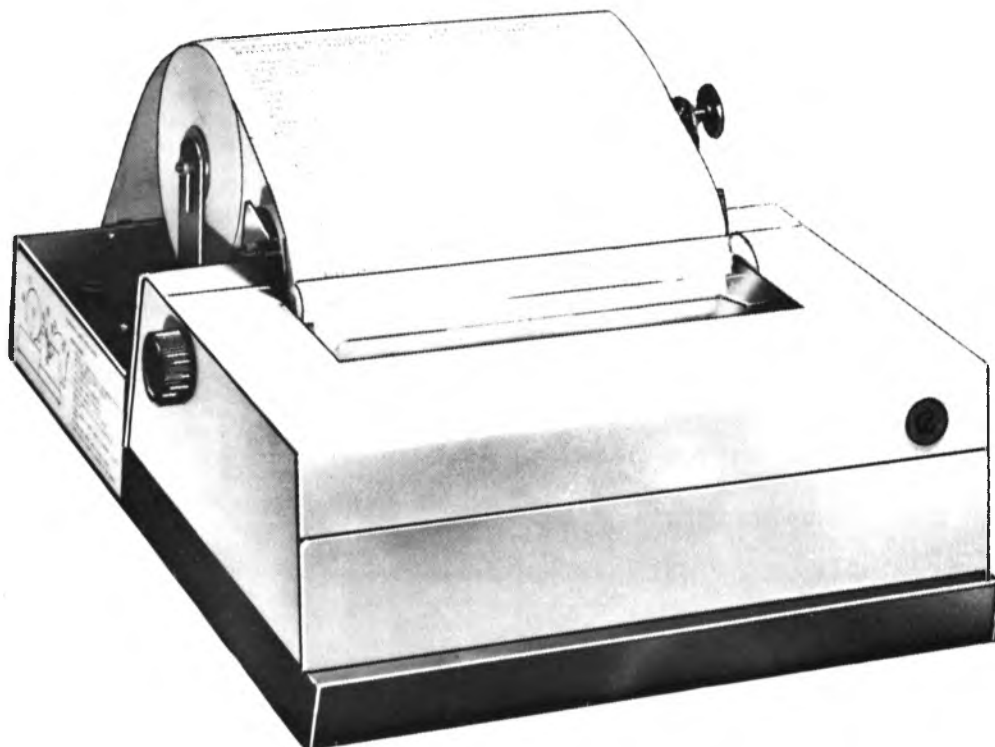

Figure 1-1 Series AH Teleprinter

### A NEW LINE OF 30 CPS PRINTERS

#### 1-1. GENERAL

The Series AH Teleprinter is a solid-state, electronic, receive-only unit which provides a 5 x 7 dot matrix printout upon receipt of serial data from appropriate transmission sources. The unit is designed for continuous- or intermittent-duty applications, and is capable of printing asynchronously at any speed up to 30 characters per second.

Series AH Teleprinters are designed to operate from either a 115 V AC or 230 V AC, 50 to 400 Hz, power source. Though the electronic control circuitry is advanced, the printing mechanism of every teleprinter in the series is simple—and every machine operates with little noise and great reliability. Thanks to the machine's modular construction, the electronic and mechanical assemblies can be removed easily, and many components may be used interchangeably, wherever feasible.

The teleprinter cover has a hinged lid, allowing easy access to the typing unit for paper and ribbon threading. A window, built into the hinged lid, makes the copy visible during data reception and provides a cutting edge for the removal of completed messages from the machine.



## 1-2. PRINCIPLES OF OPERATION

The following is a general discussion of the basic principles of operation. A more detailed analysis of operation is provided in subsequent sections of the manual.

### a. Character Printing and Spacing

Printing takes place when the paper is struck by any of seven electronically-activated needles mounted vertically in the carriage assembly. The carriage assembly is moved along the platen by a special stepper motor, which derives its impulses from the electronic circuitry of the machine. The carriage assembly moves eight steps for each character—the first three steps provide the spacing between characters, and the remaining five steps are used to print a 5 x 7 dot matrix character pattern, as illustrated in Figure 1-2.

The spacing mechanism—comprised of the spacing drive stepper motor, pulley, drive belt, drive pawl, and associated gears and capstans—laterally positions the carriage assembly so that the characters are displayed evenly in horizontal lines on the paper. The spacer is activated each time a character or space is called for in the received code. Internal logic suppresses carriage spacing when certain 'function' characters are received by the teleprinter.

### b. Paper Feed Drive Mechanism

The Paper Feed Drive Mechanism—comprised of pulleys, drive belt, platen, and a paper feed drive stepper motor—positions the paper vertically so that spacing between printed lines is consistent. 4.4 lines per inch are normally printed when the unit is functioning in the single-line feed mode. Upon receipt of a 'line feed' encoded character, the paper feed drive mechanism advances the paper vertically to the next line position.

Multiple line feeds are controlled by a three-position toggle switch at the lower left-hand side of the front of the unit. See Section 3 for instructions.

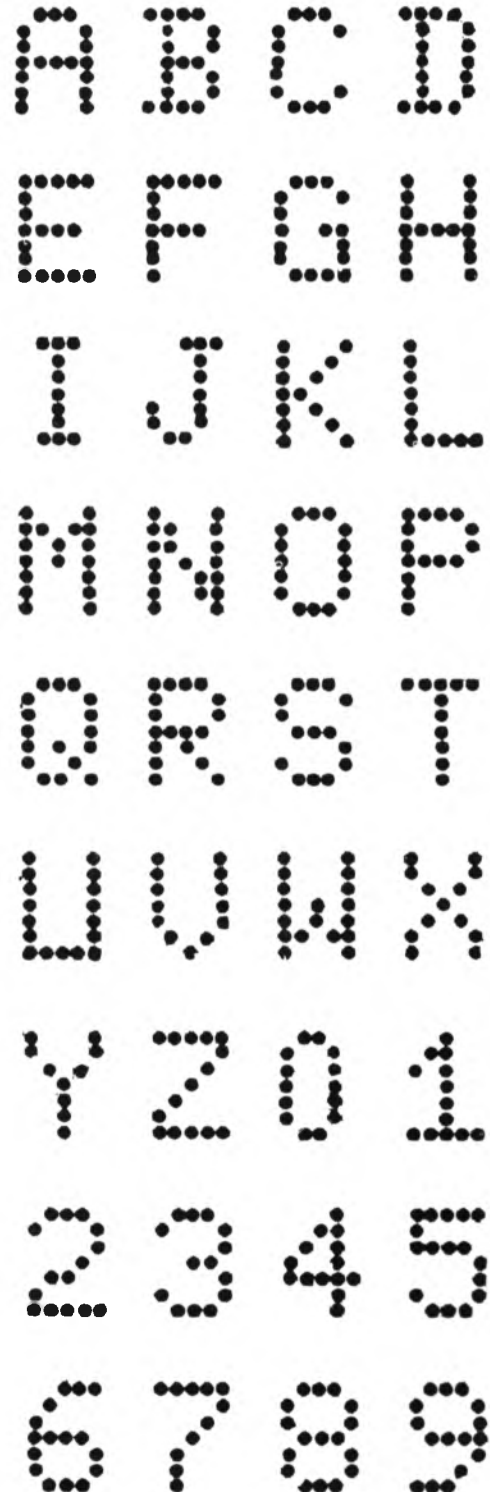

Figure 1-2 Dot-Matrix Character Formation



### c. Carriage Return

The carriage return action is performed by the spacing drive stepper motor, drive belts, and gears. Upon receipt of a 'carriage return' encoded character, the teleprinter's control circuitry causes the spacing drive stepper motor to reverse. When this happens, the idler gear disengages from the right-hand capstan, permitting the force of the carriage return spring to return the carriage to the left-hand margin to begin a new line of print. A decelerator, which is an inertia device, cushions the carriage assembly as it reaches the left side of the platen. In most instances, the carriage return function is performed coincidentally with the line feed function, so that the paper will be advanced vertically when the carriage is returned to begin a new line.

In a Series AH Teleprinter, an internal electronic counter records the lateral position of the carriage at all times. Thus, if the machine has been arranged for either a 50, 69, 74, or 80 character-per-line format, the carriage will automatically be returned to the left-hand margin when the internal counter reaches this pre-set number. This will occur whether a 'carriage return' character has been received or not. Furthermore, the electronic control circuitry of a Series AH Teleprinter determines the exact time span required to let the carriage assembly settle at the left-hand margin before the printing of a new line is begun.

## 1-3. SPECIAL FEATURES

### a. Special Character Fonts

1. *Lower Case Characters.* The AH Teleprinter incorporates a number of features which expand its printing capabilities beyond those associated with more traditional teleprinter designs. The most obvious feature is the unit's ability to print lower case characters.

The standard lower case characters are formed on a 5 x 5 dot matrix, rather than the usual 5 x 7 matrix. As a special option (specified by the purchaser at the time of ordering), lower case characters can be printed with

descenders which actually extend below the line of copy (as in the letters 'j', 'p', 'q', etc.). To accomplish this, the logic board—through its special program—moves the paper up and down on the platen while printing is in progress. This option is available only on machines operating at up to 15 characters per second.

2. *Bold Face Characters.* The Bold Face command to the teleprinter causes all subsequent characters to be printed in a 6 x 7 dot matrix, instead of the normal 5 x 7. The extra column of dots gives the characters a heavier or 'bolder' appearance. This feature outmodes the more traditional change from black to red ribbon for accenting portions of a text—and the bold face characters appear on every page of a multiple-copy form.

3. *Expanded Characters.* The ASCII AH Series Teleprinter is also equipped with an Expanded Character Set, for even more emphasis than that of bold face. Expanded characters may be used to set off page or paragraph titles, or to emphasize material within the text itself.

An expanded character is made up of six unprinted and ten printed columns, producing a 10 x 7 dot matrix character. Note: though expanded characters appear to be taller than normal ones, they are actually the same height as the others. Thus, normal line feed need not be modified for these characters.

### b. Variable-Width Underlining

The ASCII AH Series Teleprinter features an 'underline' character, printed far enough below the text line to enhance greatly the readability of the underlined characters.

Usually, the 'underline' character is eight columns wide—so that repeated underlining results in a continuous line with an even appearance. Since a normal character consists of three blank columns and five printed columns, it is necessary to suppress underlining to five columns below the first character of a sequence. The ASCII AH Teleprinter does this automatically.

The unit also accurately underlines bold face and expanded characters.





128  
CHAR.  
BUFFER  
FOR  
MANY  
SHORT  
LINES  
OF  
PRINT,  
UP  
TO  
50  
CPS

**c. Short Lines**

The Series AH Teleprinter possesses an extraordinary ability to print many short lines of text without the use of 'fill characters'. The unit's 128-character storage buffer and ability to accelerate printing speed to 50 characters per second permit the user to print lines with as few as 15 characters continuously, without exceeding the buffer's storage capacity. Additionally, up to 56 lines of 10 characters each, or 27 lines of 4 characters each, may be printed before the buffer becomes full.

**d. Auto Message**

The ASCII AH Series Teleprinter includes an Auto Message Option which, when activated, causes all of the printable characters in ASCII to be printed after power enters the unit. This option helps verify that the printer is in good working condition. However, the Auto Message Option does not test the input board.

**e. Half-Line Feed Feature**

This feature is often used for subscripts or other special requirements. The procedure can also work in reverse, for the printing of superscripts—when footnoting is desired—and exponents.

**f. Last Character Visibility (LCV)**

If a pause in the incoming data causes the carriage to stop printing for more than one second, a special interval line feed advances the paper 2½ lines upward. This makes the last characters much more readable. When incoming traffic resumes, the platen retracts 2½ line feeds and continues printing from the point where it had stopped.

**g. 96-Character Mode**

In addition to the usual 64- and 128-character modes of the ASCII code, the ASCII AH Teleprinter offers a 96-character mode with both upper- and lower-case characters.

**h. Full Monitor Mode**

In its Full Monitor Mode, the ASCII AH Teleprinter prints a unique symbol for each of the 128 possible ASCII characters, including 'fill characters' and 'control characters' (i. e., carriage return, line feed) which do not otherwise generate printed symbols. While in this Full Monitor Mode, the unit will print the symbols for carriage return and line feed, but will not execute these mechanical operations at the times they are called for in the text. Instead, the teleprinter will completely fill each line with the maximum number of characters permitted and then automatically perform a carriage return and a line feed. This mode of operation is most useful for generating compact copy and greater utilization of total printing area.

To preserve the original format of the text (in terms of line width and spacing between paragraphs), the user may engage the *Special Full Monitor Mode*. In this mode, not only are symbols printed for each of the 128 ASCII characters, but the readability of the printed copy is improved through a line format which closely resembles what would be printed if the mode were not being used.

**1-4. TELEPRINTER CODE RECEPTION**

Seven Logic Board Assemblies, each with its own requisite coding for input, are currently available in the AH Series of teleprinters. The particular board installed in any given machine is specified at the time of ordering and should be properly adjusted to conform to the user's specific requirements.



Messages transmitted to the teleprinter are in the form of on/off pulses sent on-line in rapid succession (Serialized, or Serial, Data) according to a specified signaling code arrangement. In current widely-used codes, 5, 6, or 8 on/off bits signify a given character or function. The teleprinter's logic circuitry must decode these sequences of bits to produce an intelligible printout. Standard codes which can be accepted by current AH Series machines are:

- 5-Level (Baudot), US-A, -B, -C
- CCITT No. 2 with £ sign
- 8-Level (ASCII)
- CCITT No. 5

Each character and function received by the teleprinter is represented by a series of current or no-current time intervals on a neutral DC current loop. Current flowing on-line is referred to as a 'mark', while a no-current condition is termed a 'space'. (In Polar DC systems, 'mark' and 'space' conditions are determined by the direction of current flow. In audio communications systems, a shift in the frequency of the tone on the line determines 'mark' and 'space'.)

One of the principal codes used by the telecommunications industry is the 5-Level CCITT No. 2 code. In 5-Level encoded characters, each character or function is defined by at least 7 on/off units—one start pulse, one stop pulse, and five bits (or levels) which determine the character or function. Figure 1-3 illustrates the transmitted character 'E' in this code. The start and stop pulses synchronize the message receiver with the transmission site, informing the receiver of the start and finish of each character.

Figure 1-3 5-Level Character 'E'

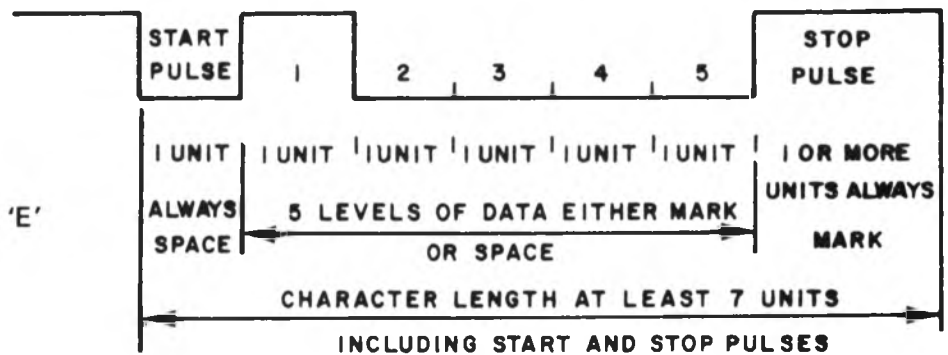

With five bits (levels) available for defining characters and functions, the CCITT No. 2 code can basically accommodate 32 permutations. However, through the 'letters' and 'figures' shift, it is possible to double the complement of characters and/or functions to 64.

CCITT No. 5 is an 8-Level code, of which USASCII is an American version. Again, start and stop pulses synchronize the message, but this code uses eight bits (levels) to define a character or function—bits 1 through 7 delineate the character, while bit 8 is used for parity. With seven levels of mark or space information available, the CCITT No. 5 code can accommodate 128 permutations. Of these, 96 are assigned to printing characters, the rest to non-printing (function) characters or no assignment. Figure 1-4 is a pictorial representation of the character 'E' in the 8-Level CCITT No. 5 code.

Figure 1-4 8-Level Character 'E'

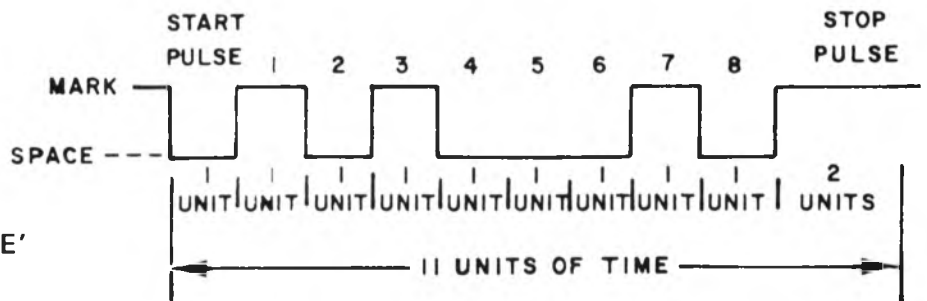

## 1-5. OPERATING FREQUENCIES

The operating speeds of the teleprinter may be changed through the Speed Control Switch, which selects any of the three crystals installed in the unit. See Chapter 3 for instructions. **CAUTION:** Power to the unit **MUST BE TURNED OFF** when changing from one speed to another.

Each crystal corresponds to a different 'Baud rate' (a quantity directly related to printing speed). Alternative speeds may be obtained by changing the crystals (located on the unit's Driver Board). Consult the following chart to select the proper crystal for the desired operating speed of the unit.

Part Number	Frequency (KHz)	Baud Rate	CHARACTERS PER SECOND				
			Baudot Unit Code		ASCII Unit Code		TTY5 Unit Code 8.5
			7.42	7.5	10	11	
2354-01	25.6	50.0	6.74	6.667	5.0	4.545	5.882
2354-02	38.4	75.0	10.108	10.0	7.5	6.818	8.824
2354-03	56.32	110.0	14.825	14.667	11.0	10.0	12.941
2354-04	57.6	112.5	15.162	15.0	11.25	10.227	13.235
2354-05	23.296	45.5	6.132	6.067	4.55	4.136	5.353
2354-06	84.48	165.0	22.237	22.0	16.5	15.0	19.412
2354-07	102.4	200.0	26.954	26.667	20.0	18.182	23.529
2354-08	51.2	100.0	13.477	13.333	10.0	9.091	11.765
2354-09	37.547	73.33	9.883	9.777	7.333	6.666	8.627
2354-10	28.8	56.25	7.581	7.5	5.625	5.114	6.618
2354-11	28.493	55.65	7.5	7.42	5.656	5.059	6.547
2354-12	37.99	74.2	10.0	9.893	7.42	6.745	8.729
2354-13	153.6	300.0	40.431	40.0	30.0	27.273	35.294
2354-14	26.9	52.539	7.081	7.005	5.254	4.776	6.181
2354-16	115.2	225.0	30.32	30.0	22.5	20.45	26.471
2354-17	76.8	150.0	20.216	20.0	15.0	13.363	17.647
2354-18	40.96	80.0	10.781	10.667	8.0	7.272	9.412
2354-19	34.15	66.7	8.99	8.893	6.67	6.063	7.847
2354-20	29.133	56.9	7.668	7.587	5.69	5.173	6.694
2354-21	43.52	85.0	11.456	11.333	8.5	7.727	10.0
2354-22	65.28	127.5	17.183	17.0	12.75	11.591	15.0
2354-23	111.7	218.18	29.404	29.09	21.81	19.83	25.66
2354-24	168.96	330.0	---	---	---	30.0	---
2354-25	130.56	255.0	---	---	25.5	23.18	30.0



### a. Sensor Unit for Low Paper Alarm

This feature can be connected by the customer to activate an external visual or audible alarm to signify that the paper roll supply is nearly exhausted. In Selective Calling applications, this feature can be used to alert the transmitting station that the teleprinter is not ready for message reception because of its inadequate paper supply. On units equipped for EIA interface, the Sensor Unit performs a similar function.

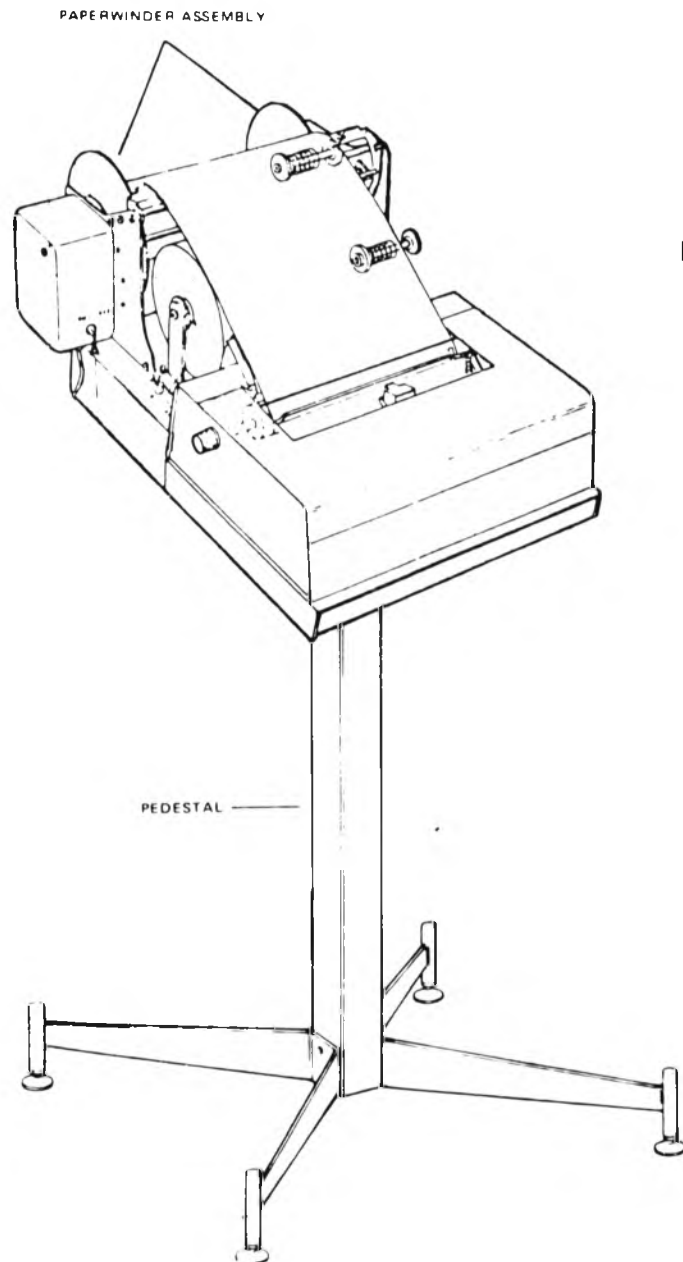

Figure 1-6 Teleprinter With Accessories

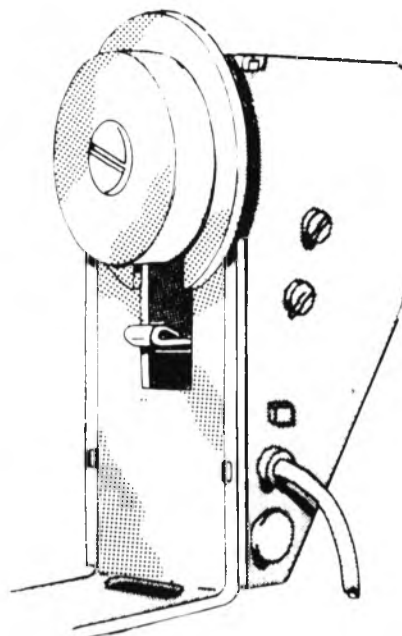

Figure 1-5 Sensor Unit for Low Paper Alarm

### b. Selective Calling

This feature is integral to the 7080 series of Logic Boards, and permits individual station selection on a common communications loop. The Selective Calling Network also contains answerback provisions.

### c. Paperwinder

This device (Figure 1-6), mounted on the rear of the teleprinter, retains all received messages on a continuous roll.

### d. Pedestal

This sturdily-constructed pedestal (Figure 1-6) supports the teleprinter at a convenient reading or working height of either 28 or 36 inches (71 or 91 cm).



## 1-7. CHARACTERISTICS AND SPECIFICATIONS

### a. Printing Characteristics

Printing Method	5 x 7 dot matrix (character by character)
Horizontal Spacing	10 characters per inch
Vertical Spacing	4.4 lines per inch (single-line feed)
Printing Rate	three speeds up to 30 cps, determined by installed crystals, selected through Speed Control Switch
Available Codes	CCITT No. 2-5-Level; CCITT No. 5-8-Level

### b. Paper Specifications

Standard Teleprinter Paper	for ribbon teleprinters
Pressure-Sensitive (Ink-Encapsulated) (up to 3-ply for multiple-copy use)	for non-ribbon teleprinters

### c. General Specifications

Duty Cycle	continuous or intermittent
Input Voltage	115 or 230 Volts AC, 50-400 Hz (single phase)
Signal Line Input (general)	signal termination isolated from ground and other circuitry, unless otherwise specified. Isolation: 2500 Volts DC. Standard series resistance: approx. 70 ohms, unless otherwise specified. Other inputs available to conform with specific customer requirements.
Signal Line Input (DC)	Neutral: 10-80 ma; Polar: 20-60 ma, or EIA standard interface RS-232-C
Signal Line Input (Audio)	Narrow-band Audio Frequency Shift Keying (FSK), CCITT standard channel spacing available. Also compatible with Bell System or equivalent Datasets 103, 108, 109, and 113.
Input Impedance (approx.)	U. S.: 70 ohms; U. K.: 4 K ohms; West German: 240 ohms
DC Distortion	Teleprinter accepts up to 41% marking or spacing distortion at any operating speed.
Audio Distortion	Teleprinter accepts up to 25% marking or spacing distortion at any operating speed.
Power consumption (approx.)	60 Watts maximum printing, 25 Watts maximum standby
Operating Temperature	32°F to 110°F (0-43°C), sea level to 10,000 feet (3048 m)
Dimensions and Mass (without paper roll)	AH-11 (non-ribbon): 5" x 15 1/2" x 12 5/8", 23 Lbs. (12.7 cm x 39.4 cm x 32.1 cm, 10.5 kg) AH-11-R (with ribbon): 5" x 17 3/4" x 12 5/8", 25 Lbs. (12.7 cm x 45.1 cm x 32.1 cm, 11.4 kg)
Mounting	desk-top surface or pedestal (28" or 36"/71 cm or 91 cm)



## SECTION 2

### EQUIPMENT INSTALLATION

#### 2-1. GENERAL

This section provides instructions for the installation of your Series AH Teleprinter. Be certain to follow all 'Notes' and 'Cautions' described in the following pages, as they are provided for your safety and for the protection of your machine.

When reference is made to the physical location of various component parts, the teleprinter is considered to be viewed from the front, or operator's position.

No special tools are required to correctly install the unit.

#### 2-2. UNPACKING AND INSPECTION

When removing the unit from its shipping carton, all instructions and cautions which might appear on the outside must be observed. The unit is enclosed in a protective, dust-proof plastic bag which is surrounded by a shock-absorbing material. This packaging material, including the carton itself, should be saved in the event that the unit must be returned or forwarded. Upon removal, the teleprinter should be thoroughly inspected for any damage which might have occurred while the unit was in transit. If any damage is evident, it should be immediately reported to the transportation company.

#### NOTE

If the teleprinter is not to be put into operation until some future time, it should be repackaged in the original packing materials. Storage temperatures may range from 32-150°F (0-66°C), at any altitude up to 10,000 feet (3048 m) above mean sea level.

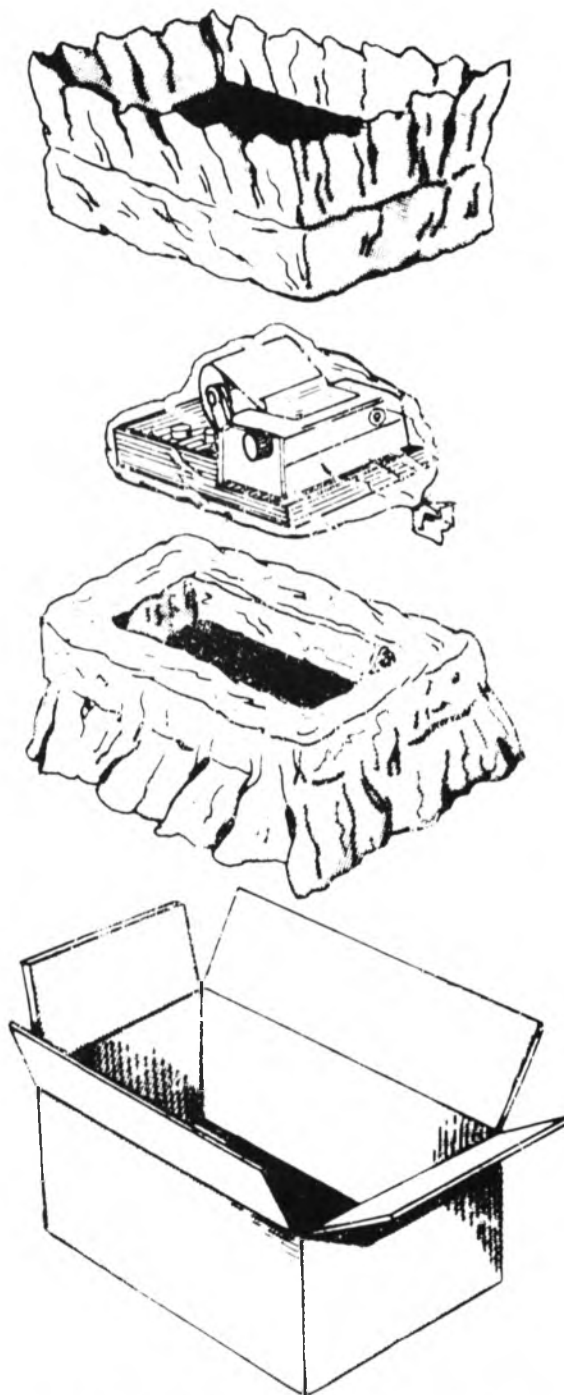

Figure 2-1 Teleprinter Packing



## 2-3. INSTALLATION LOCATION

Since the Series AH Teleprinter has an unusually low operating noise level, it may be installed without special enclosures or sound-absorbing material. In fact, it is *not* recommended that any padding or cushioning material be placed under the unit, as this could constrict air flow through the ventilation ports located underneath the machine.

The unit may be placed on any solid, level surface of sufficient area to accommodate the physical dimensions of the unit, but should not be situated in a room where the ambient temperature is likely to exceed 113°F (45°C) while the machine is in operation. Likewise, it is not advisable to locate the unit within very close proximity to sources of direct heat, such as radiators or heating ducts.

In addition, the placement of the teleprinter should be convenient to an AC power source and data terminal facility. Data reception may be provided via appropriate transmission facilities, including telegraph lines, telephone networks and radio channels.

## 2-4. CONTROLS AND INDICATORS

### a. Power ON/OFF Switch

Figure 2-2 shows the location of the Power ON/OFF Switch on the rear bracket assembly. This switch will be either of two varieties—a red-handled type, mounted so that the upward position of the handle denotes the 'ON' position and the downward position signifies 'OFF', or a black-handled type, mounted so that the handle must be moved laterally for the ON and OFF positions (as shown in the inset).

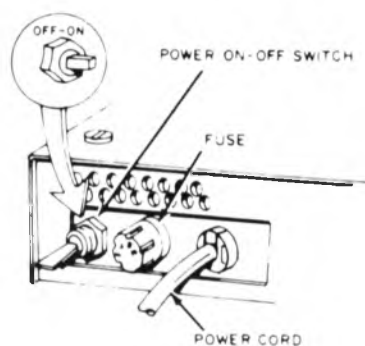

Figure 2-2 Power ON/OFF Switch

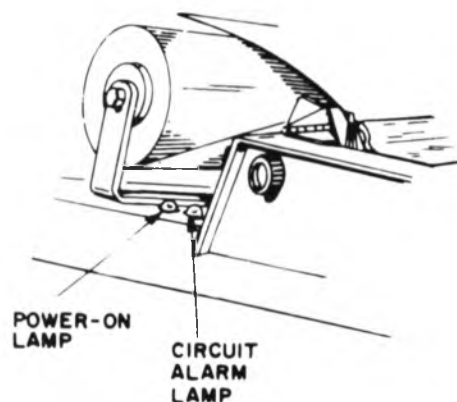

Figure 2-3 Location of Lamps

### b. Power-ON Lamp

When the teleprinter is connected to an AC power source and the power switch has been turned ON, a GREEN lamp adjacent to the left-hand side of the Paper Roll Bracket will light up (see Figure 2-3). This lamp will remain lit as long as the machine is ON.

### c. Circuit Alarm Lamp

When the teleprinter is connected to one of the various possible incoming-signal lines and signal is present, this RED lamp next to the Power-ON lamp (see Figure 2-3) will blink on and off in direct correspondence to 'mark' and 'space' conditions on the line. Thus, under normal operating conditions, this lamp DOES NOT remain lit. If, however, there is a faulty signal line connection to the teleprinter, or if for some other reason normal line signals are not present, the RED Circuit Alarm Lamp will remain lit continuously until the proper signal returns.



d. Speed Control Switch

This switch is located under the front panel in the lower right-hand corner of the unit. (On some older models, the switch is inside the machine—below the ribbon assembly, on the right-hand side.) Moving the switch handle to one of three possible positions selects a crystal-controlled operating speed.

2-5. POWER INTERFACE

**CAUTION**

Before making any power or signal line connections, place the Power Switch (shown in Figure 2-2) in the OFF position.

a. General

Every Series AH Teleprinter is equipped with a power cord which extends from the Rear Bracket Assembly adjacent to the fuse holder. This cord, 7 to 9 feet long, meets the electrical specifications of the geographical area in which the machine is to be operated. One end of the power cord is normally terminated in a three-prong male plug for connection to an external AC power source meeting the specifications outlined on the model data plate affixed to the right-hand side of the machine.

Units designed to operate from a 230 VAC power source are not usually terminated with a plug. In this and other cases in which no plug is provided, the installer must provide one of proper configuration for connection to power receptacles in the user's area.

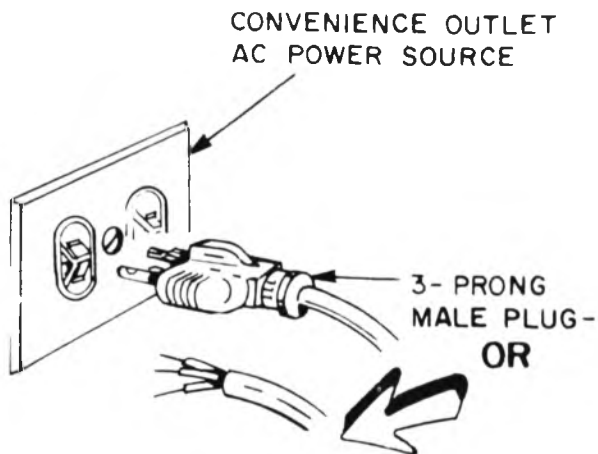

Figure 2-4 3-Prong Hookup

b. Changing Operating Voltage

Your machine has been wired to operate from either a 115 or a 230 VAC power source, 50 to 400 Hz. Check the Status Card attached to the machine to ensure that the machine has been wired to meet the voltage requirements of your area.

If—for whatever reason—the operating voltage of the unit must be changed, the installer must gain access to the power supply transformer within the cabinet. To do this, follow the instructions outlined in the later entry entitled *Internal Access*.

To change the operating voltage, remove the transformer's protective plastic cover by loosening its two retaining screws and sliding the cover while lifting upward. Referring to Figure 2-5,

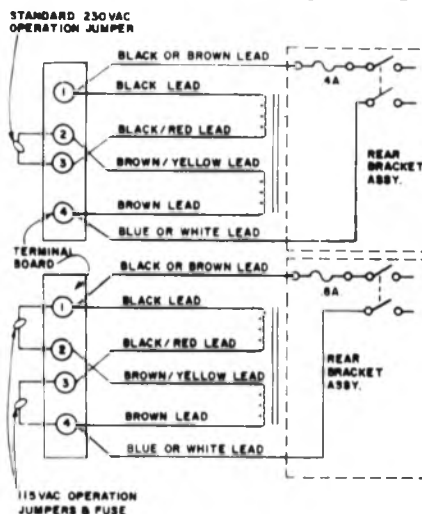

Figure 2-5 Dual Transformer Schematic

remove the existing jumper wire(s) and solder new jumper wire(s) to the appropriate terminals, as shown in the schematic.

**NOTE**

When the operating voltage is changed, the fuse (housed in fuse holder on rear bracket) must also be changed to conform to the values shown in Figure 2-5—1 amp for 115 VAC and 0.5 amp for 230 VAC operation.

Once the jumper wires have been soldered to the correct terminals, the protective cover may be restored and the cabinet re-assembled.

When it is certain that the teleprinter meets the electrical specifications of the area in which it is to be used, the power cord may be connected to the appropriate receptacle.





## 2-6. SIGNAL INTERFACE

### a. Neutral/Polar/Audio Lines (2 wire cable)

A Series AH Teleprinter may come equipped with any of a variety of connectors attaching the signal line to the machine. In general, the signal line is attached either as a 'hard-wired' cable, extending from the rear of the unit, or may be fitted with a connector which mates with a signal line receptacle mounted on the teleprinter's rear panel.

The signal line cable may be terminated—hooked up to a data source—in a number of ways. Figure 2-6 illustrates the most common forms of termination for units designed to operate with DC current loops or audio input signals. Before making any signal line connections, check the Status Card attached to the machine for complete information on the type of signal your machine is designed to accept.

#### CAUTION

If a teleprinter equipped for audio signal use is connected to a DC source, serious damage to the input board will result. No damage will occur if the reverse connections are made; however, the teleprinter will be inoperative after AC power is applied, and the Circuit Alarm lamp will light to signify an open circuit.

The teleprinter is designed to operate normally from any DC signal line current, neutral or polar, between 10 and 60 milliamperes. However, if the unit is to be operated from peripheral equipment have a higher current rating than 60 milliamperes, current limiting resistor(s) of proper value must be wired in series with the DC input signal line. If specified at the time of ordering, the resistor(s) will be factory-installed on the input printed circuit board. Provisions have been made on this board to switch different resistors in series with the loop for field modification.

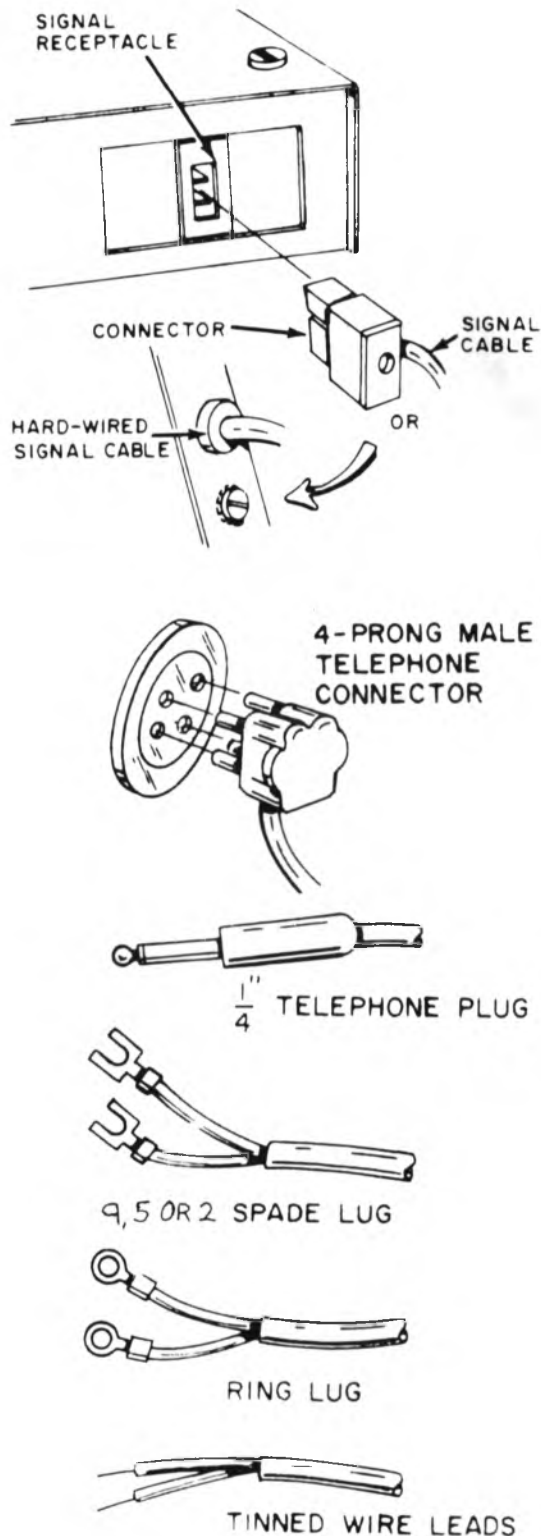

Figure 2-6 Typical Signal Line Terminations



When the teleprinter is interfaced with an external audio modem, the current setting should be between 30 and 50 milliamperes in the 'mark' condition. Refer to the external modem instruction manual (provided by the manufacturer of the external modem) for specific adjustment procedures.

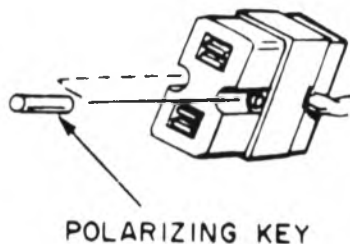

Figure 2-7 Polarizing Key

**NOTE**

When initially connecting the signal line, it may be necessary to reverse the polarity of the line before the teleprinter will receive properly.

To reverse the polarity of the signal line on units which utilize the connector/receptacle method of attachment to the teleprinter, simply remove the signal line connector and locate the polarizing key wedged into its housing (see Figure 2-7). Pry this key out of the housing and re-install it on the other side of the connector. Re-insert the connector into the signal-line receptacle.

On machines with a 'hard-wired' signal line cable, it will be necessary to reverse the leads at the terminal connecting point in order to change polarity.

If printer is equipped with 9-wire cable, refer also to section 2-6c.

**b. RS-232 (EIA) Interface**

(5 wire cable only)

The signal-line cable used with this EIA-type interface is generally 'hard-wired' to the teleprinter and terminated with a 25-pin connector (see Figure 2-8). Any Series AH Teleprinter which is designed especially for this type of interface uses the following pins and signals on this connector:

Pin 1	Protective Ground
Pin 2	Transmitted Data (always -12 VDC)
Pin 3	Received Data
Pin 7	Signal Ground
Pin 20	Data Terminal Ready (+12 VDC) or Low Paper Sensor



Figure 2-8 25-Pin EIA Connector

**NOTE**

After the signal line has been connected, be certain that the teleprinter's Speed Control Switch has been set for the proper baud rate. The Status Card on the machine will tell you the three baud rates at which your particular machine can operate.

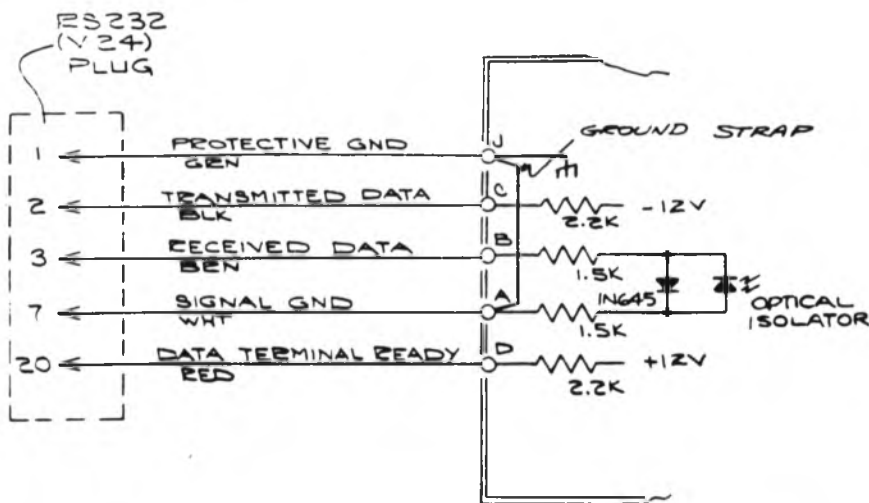

Figure 2-9 EIA Interface Wiring Diagram



c. **Polar or EIA Interface with 9-wire cable.**

Your machine may come equipped with a 9-wire signal-line cable, designed to enable either polar or RS-232 (EIA) operation to be employed, merely by swapping the interface card.

If ordered for RS-232 (EIA) operation, the machine will usually be terminated with a 25-pin connector, as shown in figure 2-8, and the connections will be as shown in figure 2-9 (no account should be taken of the cable colours in this case however, which are as shown below).

Wire Colour	Function
White	Input Signal Common
Brown	Input Signal
Red	Data Terminal Ready (EIA only)
Blue	Transmit Data Out (Polar only)
Orange	+ 80 volts DC Input (Polar transmit)
Yellow	- 80 volts DC Input (Polar transmit)
Green	Low paper contacts (Polar only)
Violet	Closed when paper is low
Black	Transmit Data Output (EIA only)

**Figure 2-10 9-wire signal-line cable connections**

N.B. The polar and EIA transmit wires will not normally be used.



## 2-7. PROGRAMMING OPTIONS

Under normal circumstances the teleprinter is ready to be put into operation just as it arrives from the factory. If specified at the time of ordering, the Logic Board in each machine has been programmed to provide any options requested. In some instances, however, it may be necessary for the installing technician to change the printing requirements of the unit, and the following charts provide the information necessary to do this.

The various printing options described in Section 1 of this manual, as well as the Selective Calling option, are controlled through the 8-position dual-inline ('dip') switch array located on the Logic Board. In order to gain access to the Logic Board, it will be necessary to follow the disassembly procedure outlined later in this section under *Internal Access*.

### a. 7981 Series 5-Level Logic Board

Switch	ON/OFF	Effect
1, 2, 3, 4	—	no effect
5	OFF ON	3, 5 Character Selective Calling (separated by space characters) 2 Character 83B3
6	OFF ON	Normal Bold Face Heading (only if switch 5 is OFF)
7	OFF ON	Selective Calling Enabled Selective Calling Disabled
8	OFF ON	72-Character Line 40-Character Line

### b. 7085, 7086, 7087, 7986 Series 5- /8-Level Logic Board

Switch	ON/OFF	Effect
1	OFF ON	Normal Auto Message is printed when Power Switch is turned ON.
2	OFF ON	Normal Last Character Visibility ON
7, 8	7 OFF, 8 OFF 7 OFF, 8 ON 7 ON, 8 OFF 7 ON, 8 ON	50-Character Line 69-Character Line 74-Character Line 80-Character Line



8-LEVEL ONLY:

5-LEVEL ONLY:

8-LEVEL ONLY:				5-LEVEL ONLY:	
Switch	ON/OFF	Effect	Switch	ON/OFF	Effect
3, 4	3 OFF, 4 OFF	64-Character Mode	3	OFF	Normal
	3 OFF, 4 ON	96-Character Mode		ON	Full Monitor Mode
	3 ON, 4 OFF	128-Character Mode	4	OFF	Bell on 'J' (CCITT No. 2)
	3 ON, 4 ON	128-Character Mode (Special)		ON	Bell on 'S' (U. S.)
5, 6	5 OFF, 6 OFF	Normal	5	OFF	Normal
	5 OFF, 6 ON	New Line on Carriage Return		ON	New Line on Line Feed
	5 ON, 6 OFF	New Line on Line Feed	6	OFF	Normal
	5 ON, 6 ON	New Line on Line Feed		ON	New Line on Carriage Return

The jumper wires on these boards are also significant. If JU-2 is inserted, the teleprinter will operate on Baudot Code; if not, it will operate on ASCII. JU-3 is inserted only if the Five-Bell Alarm Option has been specified. JU-4, even on models in which it may be inserted, has no effect.

2-8. INTERNAL ACCESS

a. Teleprinter Cover Removal/Replacement

To remove the teleprinter cover, proceed as follows:

- (1) Cut the paper and remove any excess paper which may be threaded around the platen.
- (2) Pull the platen knob off the platen shaft.
- (3) Loosen the screw on the rear of the cover until it clears the retaining bracket slot by approximately 1/4 inch (5/8 cm). This single screw holds the teleprinter cover to the printer base.
- (4) Slide the cover slightly toward the front of the machine to permit the cover mounting lip to disengage from its retainer at the front of the printer base.

**CAUTION**

To avoid damaging the platen shaft when removing the cover, carefully move the teleprinter cover to the left so as to clear the platen shaft.

**WARNING!**

VOLTAGES DANGEROUS TO LIFE ARE PRESENT IN THIS EQUIPMENT! Disconnect primary AC input power prior to attempting assembly removal and replacement.

- (5) Slowly and carefully lift upward and to the left, removing the teleprinter cover.

**NOTE**

Steps (1) through (5) are to be reversed for re-attachment of the teleprinter cover.

b. Access to Printed Circuit Board Assemblies

To obtain access to the electronic printed circuit board assemblies of the unit, proceed as follows:



- (1) Remove the teleprinter cover as directed in the preceding paragraph.

**CAUTION**

Observe the orientation of the four connector boards to the right of the typing unit, and tag the boards for re-assembly. They must be reinstalled in the proper direction when the unit is reassembled, or serious damage to the teleprinter may result.

- (2) Disconnect the four connector boards at the right side of the typing unit by pulling upward on each of them.
- (3) Remove the five power supply cover

mounting screws located on top of the unit in the paper roll area.

- (4) Remove the printer base mounting screws, which secure the printer base to the electronics base.
- (5) Slowly and carefully lift up on the integrated assembly comprised of: typing unit, power supply cover, and printer base. This will expose the electronics base and its circuit board assemblies.

**NOTE**

Steps (1) through (5) are to be reversed for reassembly of the teleprinter cabinet.

**2-9. 14250, 14252 and 14281 High-Level Interface Boards.**

To alter the mid-point switching level for the desired signal line current, a trim-pot on the PC board must be adjusted. Proceed as follows:

1. Remove the Power Supply Cover.
2. Using a local battery source capable of providing a current level equal to that of the loop in which the terminal will operate, connect a milliammeter and suitable resistor in series with the terminal on a local loop.

**NOTE:** The teleprinter must be connected to the local battery in a direction so that the red LED is out when AC power is applied.

3. Adjust the variable resistor until the milliammeter reads one-half the actual loop current. (ie, 30ma for a 60ma loop, 20ma for a 40ma loop, 10ma for a 20ma loop.)
4. Adjust potentiometer R35 on the 14250 and 14252 boards, R28 on the 14281 board, until the red LED just turns on. This completes the adjustment.
5. Reassemble the cabinet.



## SECTION 3

### OPERATING INSTRUCTIONS

#### 3-1. GENERAL

This section of the manual deals with tasks which are usually performed by the operator. The operator frequently installs new paper and ribbon, and can prolong the operational reliability of the unit by performing these tasks consistently and correctly. It is important that the operator learn the proper procedures for these and other tasks.

Once the teleprinter has been properly installed and connected to appropriate signal and power sources (per Section 2), it is basically ready for operation. If, however, the teleprinter behaves abnormally while any of the tasks in this section is being performed, it is recommended that you notify an authorized service technician as soon as possible.

#### 3-2. PAPER INSTALLATION

##### a. Types of Paper

A teleprinter with a ribbon mechanism uses any standard teleprinter paper, 8 1/2" (216 mm) wide, with a roll diameter of 5" (127 mm) or less and an inner core (spindle) diameter of 1" (25.4 mm). The machine will operate with up to three-ply paper.

A teleprinter not equipped with a ribbon mechanism uses pressure-sensitive, ink-encapsulated paper. This paper is available in rolls with the same width and outer diameter as standard paper, but with an inner core (spindle) diameter of 7/16" (11.1 mm). A Series AH Teleprinter equipped with a ribbon mechanism can use pressure-sensitive paper, if the paper roll mounting bracket is altered to accommodate the smaller spindle diameter (see Section 14).

##### b. Paper Loading

<b>CAUTION</b> Before attempting to load paper into the machine, turn the Power ON/OFF Switch to the OFF position. If your machine is equipped with a paperwinder, its Power Switch must also be placed in the OFF position.
--

The correct loading of paper into the machine is the single most important task which must be performed by the operator. Use Figure 3-1 to identify parts of the machine referred to in the following outline. Figure 3-2 shows a side view of the correctly-threading paper path through the machine.



- (1) Remove the gum label or adhesive securing the starting edge of the paper roll.
- (2) Unroll a sufficient amount of paper spoiled by the adhesive and cut it off with a pair of scissors. (A square cut makes the initial insertion of paper easier.)
- (3) Pull outward on the paper roll knob and insert the paper roll onto the paper roll bracket assembly so that the paper feeds from the underside of the roll. Release the paper roll knob, allowing the bushing on the knob to settle into the paper roll core.
- (4) Raise the hinged lid of the front cover and pull forward the bail wire tab, located on the left side of the bail wire, to move the bail wire away from the platen.
- (5) Pass the starting edge of the paper over the hinged plate assembly and insert it into the opening between the separator bracket and the upper hex tie rod. (Insert the paper as far as it will go without wrinkling.)
- (6) Rotate the platen knob toward the rear of the unit to advance the paper around the platen and over the separator bracket. If the paper is slightly off-center, depress the pressure roll release lever and center the paper manually.
- (7) Return the bail wire to its original position and close the hinged lid.

If a paperwinder assembly is not being used, the paper threading procedure is complete. The Power ON/OFF Switch may be returned to the ON position.

**NOTE**

For your convenience, the paper is marked with red warning stripes to indicate the end of the roll. When they appear, the paper should be changed at the next convenient interval.

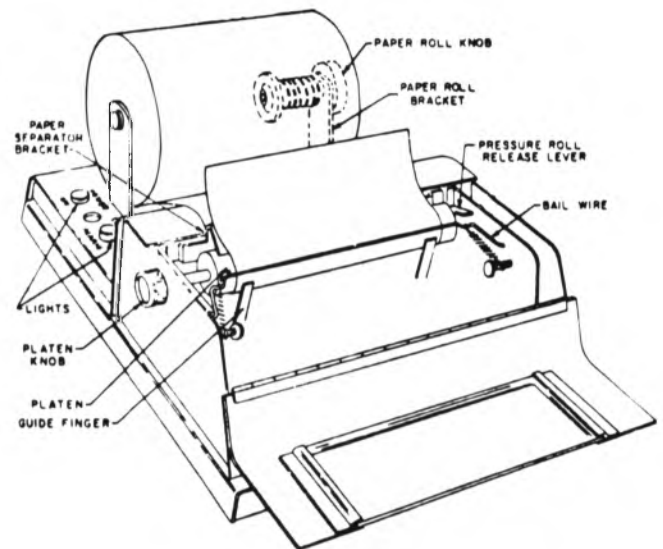

Figure 3-1 Paper Handling Components



Figure 3-2 Paper Threading Path

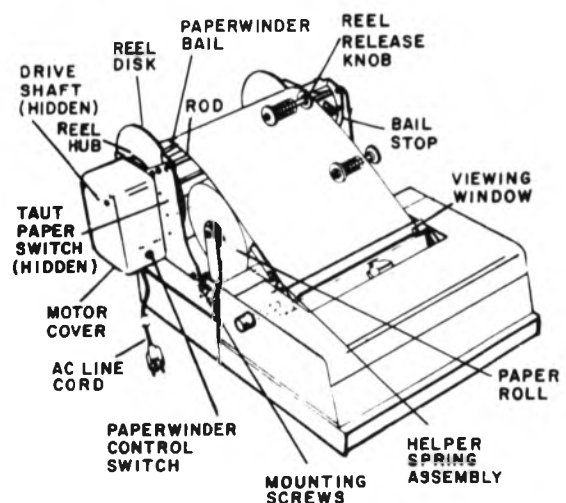

Figure 3-3 Paperwinder Components





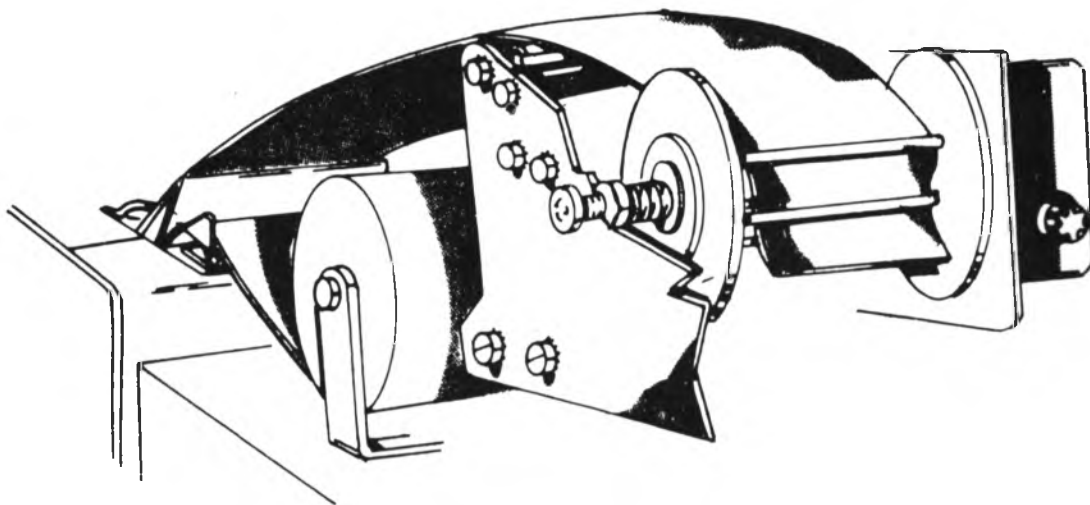

Figure 3-4 Paper Entering Paperwinder

If a paperwinder assembly is being used, leave the power switches in the OFF positions and complete the threading procedure described below.

- (8) Make sure that the edges of the paper move freely between the inside faces of the paperwinder discs.
- (9) Turn the platen knob to advance the paper approximately two feet.
- (10) Pass the starting edge of the paper over the paperwinder bail and insert it between any two rods on the takeup reel, as shown in Figure 3-4.
- (11) Turn the Paperwinder Power ON/OFF Switch to the ON position. (The paperwinder reel will begin to rotate, taking up any slack in the paper.)
- (3) While still holding the reel release knob, move the paperwinder takeup reel towards the reel release knob to free the motor drive shaft from the left reel hub.
- (4) When the left reel hub has cleared the motor drive shaft, remove the paperwinder takeup reel from the paperwinder mounting bracket and release the knob.
- (5) Position the takeup reel with one disc on a flat surface and pull upward on the top reel disc until the rods separate from the discs and the roll of paper can be removed.
- (6) Reassemble the takeup reel by inserting the tapered ends of each pair of rods into their respective holes on the opposite reel disc.

This completes the paper threading procedure. The teleprinter's power switch may now be turned to the ON position to begin operation.

#### c. Removal of Paper from Paperwinder

- (1) Turn the teleprinter and paperwinder power switches to their OFF positions.
- (2) Support the underside of the paper wrapped around the paperwinder takeup reel with one hand and pull the reel release knob with the other hand.

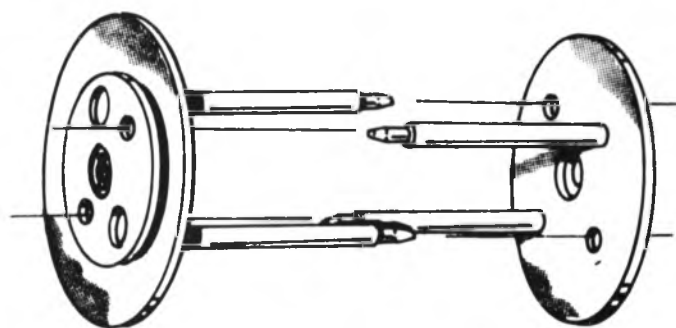

Figure 3-5 Takeup Reel Separation



### 3-3. RIBBON INSTALLATION

**CAUTION** Place the teleprinter's Power ON/OFF Switch in the OFF position to keep the machine from printing while the ribbon is being installed.

A Series AH Teleprinter equipped with a ribbon mechanism is designed to use a standard NYLON teleprinter ribbon with spools. It is imperative that a NYLON ribbon be used to prevent the build-up of cotton fibre in the carriage assembly. The proper ribbon may be ordered from Extel Corporation (see Section 14). The ribbon should be discarded when the printed characters become illegible or too light to read. After the ribbon has begun to wear out, the operator can get more use out of it by switching the spool positions, thus inverting the ribbon.

To reach the ribbon, raise the hinged lid of the teleprinter cover and note the diagram (reproduced here as Figure 3-6) affixed to the inside of the cover. One should refer to this diagram while installing the ribbon, to ensure that the proper threading path is followed.

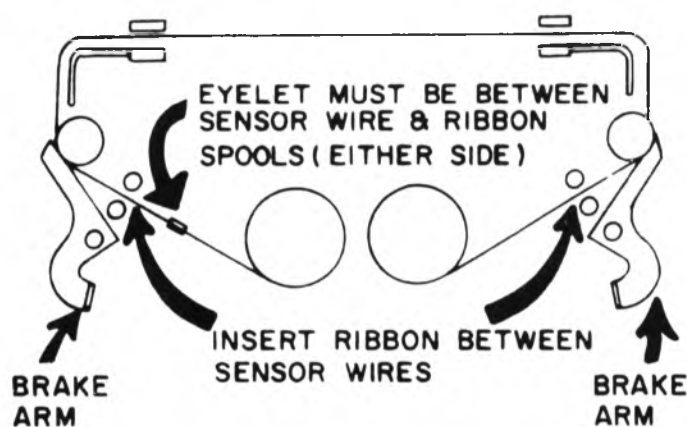

Figure 3-6 Ribbon Threading Diagram

(1) Gently pull the bail wire tab to move the bail wire away from the platen.

(2) If the ribbon spools are to be discarded, or if the ribbon is to be inverted, do the following before proceeding to Step 3:

- Carefully clear the ribbon from the left- and right-hand sensing wires.
- Depress one of the brake arms inwardly (toward the rear of the machine) and lift the ribbon free of its guide spool (where the ribbon rests when the brake arm is in place).
- Repeat this procedure for the other brake arm.
- Unthread the ribbon from the remaining guides.
- Lift the ribbon spools off of their spindles.

**CAUTION** Extreme caution should be used when lifting the ribbon between the carriage and the platen. DO NOT attempt to pull out the carriage assembly or serious damage may result.

(3) If your replacement ribbon has a new takeup spool preconnected to it, proceed to Step 4. If the spools are not pre-connected to the ribbon, do the following:

- Engage the hook at the end of the ribbon over the protruding arrow in the hub of the empty spool. If no hook is available, pierce the end of the ribbon over the point of the arrow (see Figure 3-7).
- Wind the ribbon onto the spool in the direction of the arrow (as if the spool is being turned in that direction) until the reversing eyelet has been wrapped around the spool.

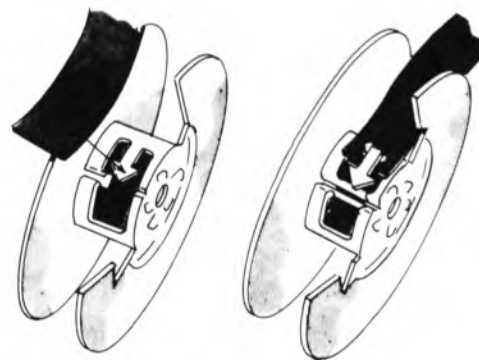

Figure 3-7 Attachment to Spool



- (4) Ensuring that the reversing eyelet is wrapped around the takeup spool, place that spool on one of the spindles and make sure that the guide pin is engaged under the spool.
- (5) Unwind approximately 18 inches (45 cm) of ribbon from the full spool and then place that spool on the other spindle, engaging it on its guide pin.

#### NOTE

Be sure that the orientation of the spools and ribbon is as shown in Figure 3-6.

- (6) Starting from the full spool, thread the ribbon through the sensing wire and then depress and hold the brake arm inward (towards the rear of the machine) while guiding the ribbon around the guide spool. Release the brake arm.
- (7) Guide the ribbon around the platen guide and then adjacent to the platen. At the carriage, *carefully* guide the ribbon between the carriage and platen.

#### CAUTION

Extreme caution should be used when placing the ribbon between the carriage and the platen. Do not attempt to pull out the carriage assembly or serious damage may result.

- (8) Continue threading the ribbon through the remaining guides on the other side, i. e., around platen guide and guide spool, through the sensing wire.
- (9) Rotate the takeup spool until the slack in the ribbon is tightened out, and again check to be certain that the reversing eyelet is between the sensing wire and the takeup spool. (If it is not in this position, the ribbon will not automatically reverse—and damage could be done to the ribbon mechanism.)

- (10) Return the bail wire to its original position, close the hinged lid, and place the Power ON/OFF Switch in the ON position.

### 3-4. MESSAGE REMOVAL

#### a. Single-Copy Paper

To remove a transmitted message on single-copy paper from the teleprinter which is not equipped with a paperwinder, turn the platen knob to advance the paper until the last printed line clears the top surface of the viewing window. Pull the paper *forward and to the right or left* against the viewing window to tear the message off.

#### b. Multi-Copy Paper

When removing multiple copies from the machine, take the following steps to eliminate uneven, ragged, or mutilated message material:

- (1) Place the thumb of your left hand on the printer cover while holding the papers *entering* the teleprinter (from the paper roll) with the fingers of the *same* hand. (This will keep paper from feeding through the machine during the tearing-off process.)
- (2) While pressure is being applied by the left hand, grasp the left corner of the paper *leaving* the teleprinter with your *right* hand, and pull smartly forward and to the right against the viewing window (see Figure 3-8). The resulting separation will be straight and parallel to the lines of copy.

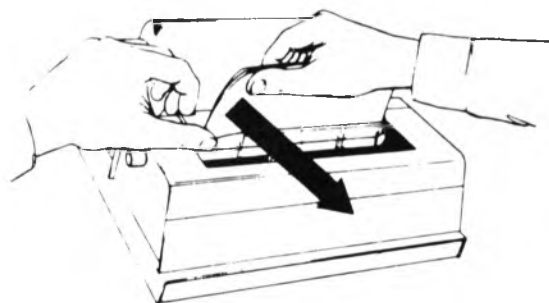

Figure 3-8 Multi-Copy Removal



### 3.5. OPERATING CHARACTERISTICS

This portion of the section outlines the general and specialized operating characteristics of the Series AH Teleprinter. The machine is totally inaudible when not printing and extremely quiet during the printing process, even when operating at speeds up to 50 characters per second—as it is capable of doing. This makes the unit ideal as a desk-top unit, especially in an office where low noise levels are desirable.

The Series AH Teleprinter incorporates a number of unique features which are described in some detail in Section 1 of this manual. Depending on its programming, your machine may perform any combination of the features outlined in Paragraph 1-3. If your machine has been programmed for Page Format, you will notice that a large space appears between every 39 lines of copy. This permits the tearing (or cutting) of the paper into neat 11-inch (28 cm) pages.

Your particular machine may advance the paper upward every time printing ceases. If so, the unit has been programmed for Last Character Visibility (LCV). This feature allows greater visibility of the last line printed.

**CAUTION** DO NOT attempt to restrict the movement of the carriage assembly. This could cause the carriage assembly to be forced against the right-hand side of the platen, possibly causing damage to the carriage.

#### a. Line Feed Switch

The three-position Line Feed Switch is located on the lower left-hand side of the front of the unit. It generates one line feed when positioned to the LEFT, one and one-half line feeds when in the CENTER position, and two line feeds when placed to the extreme RIGHT. From time to time the operator may wish to use this switch to alter the spacing between lines of copy. The switch is hidden by the front plate, but can be operated by reaching under this plate (see Figure 3-9).

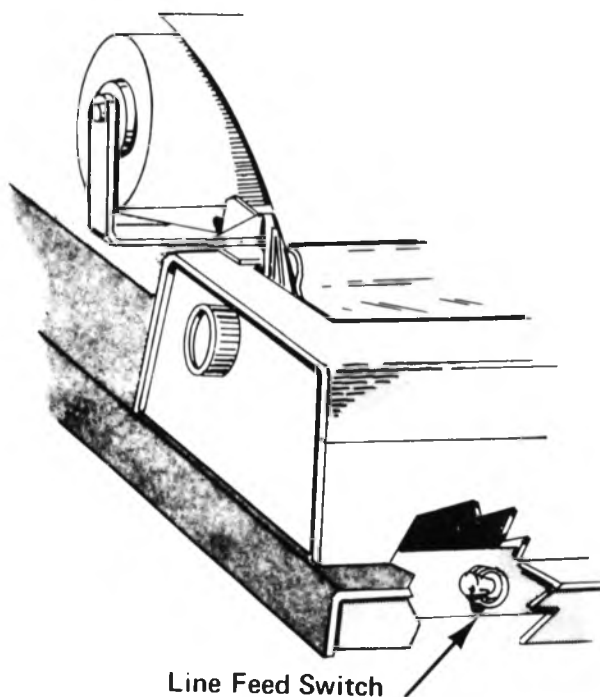

Figure 3-9 Line Feed Switch

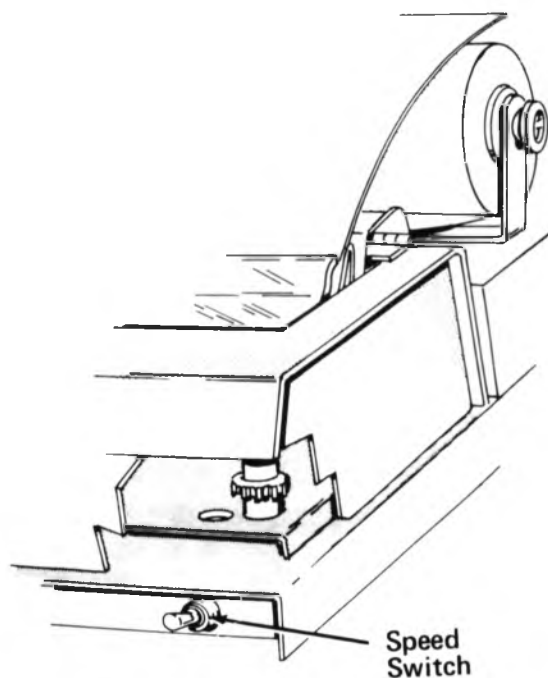

Figure 3-10 Speed Control Switch



### b. Speed Control Switch

The operating speed of the teleprinter may be changed via the Speed Control Switch (Figure 3-10), which selects any of three crystals installed in the machine. This switch is on the right-hand side of the front of the unit (except in cases noted in Paragraph 2-4), and can be operated like the Line Feed Switch.

#### CAUTION

Power to the unit must be turned OFF when its speed is being changed.

### c. Special Character Fonts

The printing of special character fonts—bold face, expanded, and lower case—is determined at the transmitting site. The ASCII AH Series Teleprinter is a receive-only unit, and the operator cannot alter the typography of received messages.

The teleprinter executes its bold face and expanded characters when it receives an 'escape' code (a control character which is expressed as 'ESC' followed by a numeral). If the teleprinter receives 'ESC 3' from the transmitting site, it will print the subsequent messages in bold face. 'ESC 4' returns the printer to standard type. 'ESC 6' initiates expanded characters, while 'ESC 5' ends them. Lower case characters are included in the ASCII character set and do not require escape codes to be initiated nor to be cancelled.

### d. Half-Line Feed/Reverse Half-Line Feed

For a Series AH ASCII Teleprinter, the character sequence 'ESC 9' causes the platen to advance one-half line feed, making the

printing of subscripts possible. 'ESC 8' causes a reverse half-line feed, for exponents, superscripts, and footnoting.

## 3-6. OPERATOR-LEVEL MAINTENANCE

In general, your Series AH Teleprinter will provide trouble-free performance for long periods of time without extensive maintenance. There are, however, some simple maintenance procedures which will help extend the trouble-free life of the unit.

- The teleprinter should receive periodic preventive maintenance at regular intervals by a qualified service technician.
- All torn bits of paper should be removed from inside the cover. Excessive lint from the paper may be removed with a soft-bristle brush in *slow*, light brush strokes to keep the lint from being scattered to other parts of the machine.
- Exterior metal surfaces may be cleaned with a mild cleaning detergent (such as Fantastik)—which should be wiped off immediately with a paper towel or lint-free cloth.
- A mild detergent may also be used to clean the viewing window, but a protective cover should be placed over the internal mechanism to prevent the cleaning agent's spray from entering it.

#### CAUTION

Only qualified service personnel should attempt to clean the carriage assembly.





# TRANSTEL COMMUNICATIONS LTD.

Mill Street, Slough,  
Berkshire, SL25DD  
England  
Telex: 849384

Subsidiary of:  
Extel Corporation  
310 Anthony Trail  
Northbrook, Illinois 60062 USA  
Telex: 72-4398

(No connection with Extel group of companies, London.)